



StripLite Led RGBW

KEY FEATURES

- Ideal digital substitute of the analog strip light
- Cosmetic design for high-end installations
- Thick aluminium, long lasting light source in long lasting body
- Variable light projection angle to adapt the application
- No fan, no maintenance, no noise
- ETL approved
- Internal/External gel fram for diffusion filters

StripLite Led RGBW

SPECIFICATIONS

RGBW color mixing

Standard lens 12°/35°

Electronic dimmer

Synchronized, random or pulse electronic strobe

Flicker-free operation with LEDs frequency controlled via DMX from 600 Hz to 19000 Hz

ETL approved

Weatherproof rating IP20 or IP65

PHYSICAL SIZE (standard version)

Length: 1010 mm (39.7 in)

Width: 95 mm (3.7 in)

Height: 152 mm (5.9 in)

Weight: 7.7 Kg (17.0 lbs)

PHYSICAL SIZE (version with optional support)

Length: 1010 mm (39.7 in)

Width: 220 mm (8.7 in)

Height: 207.4 mm (8.2 in)

Weight: 8.7 Kg (19.2 lbs)

LIGHT SOURCE

16 high intensity LEDs (RGBW)

LEDs life: 20000 hours at 70% lumen intensity maintenance

CONTROL PROTOCOL AND PROGRAMMING

USITT DMX512A

Setting, addressing, testing and measurements via LEDs display

DMX channel: 1/4/7/8/14

ELECTRICAL SPECIFICATIONS/CONNECTIONS

AC power: 90-250 V, auto sensing, 50/60 Hz, 2 m (6.6 ft) integral cable without power plug

In and Out PowerCon connectors

Power consumption: 0.43 A at 230 V, 1.11 A at 90 V - cosφ 0,9

DMX data in/out: 5 pin locking XLR



StripLite Led RGBW - Drawing Size

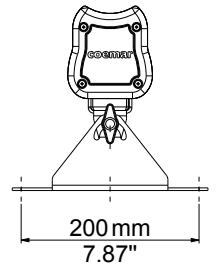
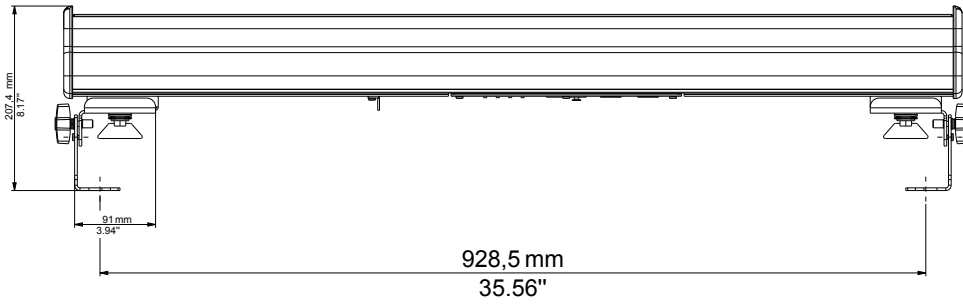
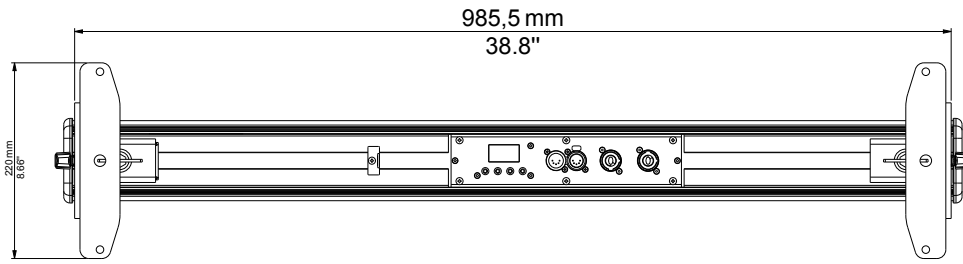

DMX Chart 14 Channels

channel	effect
1	Master dimmer
2	Red
3	Green
4	Blue
5	White
6	Strobe effect
7	Dimmer fine
8	Special functions
9	Red tone
10	Green tone
11	Blue tone
12	White tone
13	Green saturation
14	Saturation

DMX Chart 8 Channels

channel	effect
1	Master dimmer
2	Red
3	Green
4	Blue
5	White
6	Strobe effect
7	Dimmer fine
8	Special functions

DMX Chart 7 Channels

channel	effect
1	Master dimmer
2	Color temperature
3	Green saturation
4	Saturation
5	Hue
6	Dimmer fine
7	Special function

DMX Chart 4 Channels

channel	effect
1	Red
2	Green
3	Blue
4	White

DMX Chart 1 Channels

channel	effect
1	Master dimmer (color temperature settable by display)



Coemar Lighting Srl
Via Carpenedolo, 90
46043 Castiglione delle Stiviere
Mantova - Italy
ph. +39 0376 1514412
fax. +39 0376 1514380

info@coemar.com
www.coemar.com