

REFLECTION

LEDKO™

FullSpectrum 6

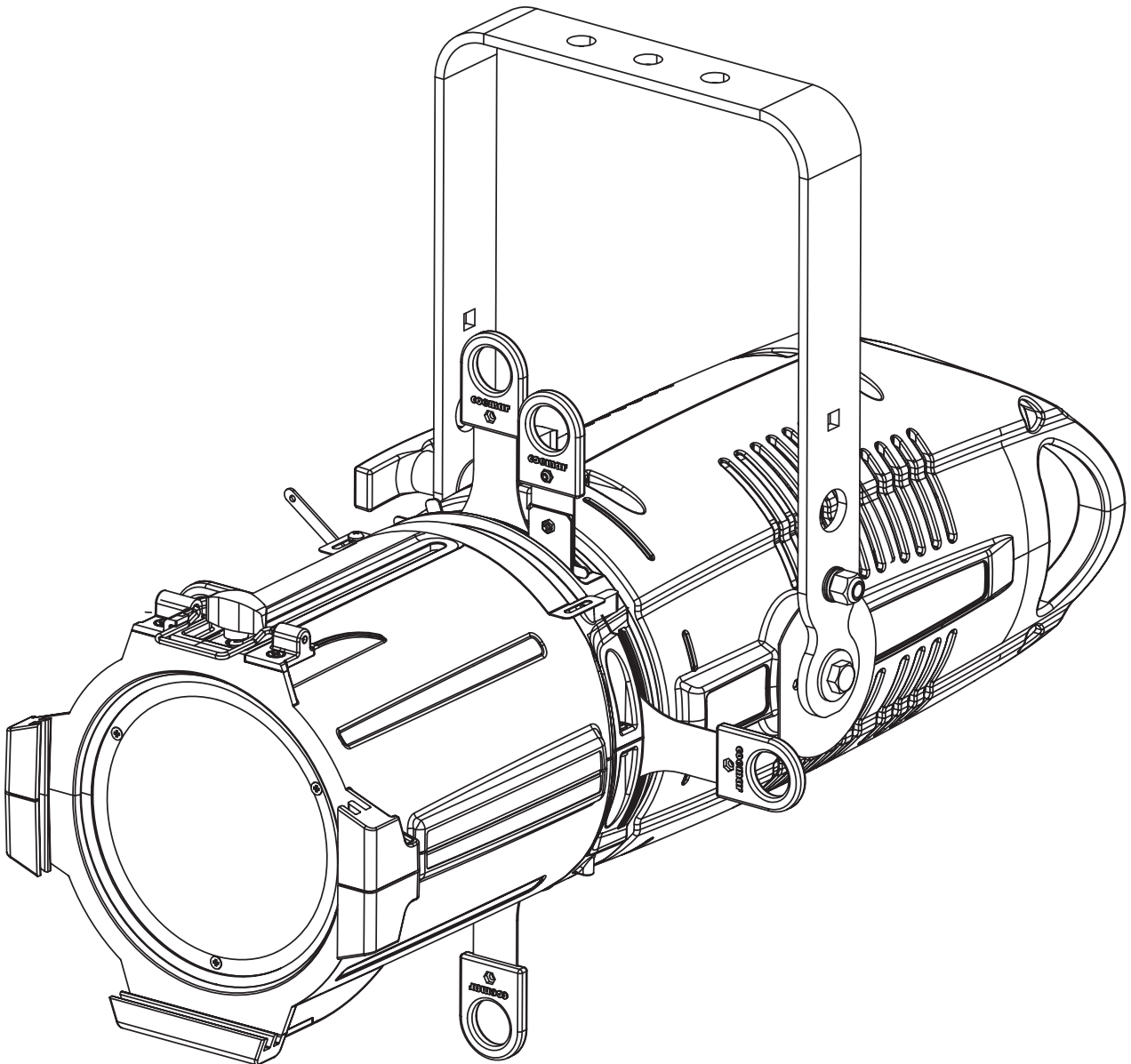

instruction manual

Version 2.0

 **coemar**
Light Emotion

REFLECTION
LEDKOTM
FullSpectrum 6

Serial Number:

.....

Purchase date:

.....

Dealer:

.....

Address:

.....

Suburb:

.....

Country:

.....

Phone / Fax:

.....

Please note in the space provided above the relative service information of the model and the retailer from whom you purchased your **LEDko FullSpectrum 6**: this information will assist us in providing spare parts, repairs or in answering any technical enquiries with the utmost speed and accuracy.

WARNING: the security of the fixture is granted only if these instructions are strictly followed; therefore it is absolutely necessary to keep this manual.

Index

1. Packaging and transportation	Pag. 5
1.1. Packaging.....	Pag. 5
1.2. Transportation.....	Pag. 5
2. General information	Pag. 5
2.1 Safety informations.....	Pag. 5
2.2 Warranty conditions.....	Pag. 6
2.3 EC Norms.....	Pag. 6
3. Product specifications	Pag. 7
3.1 Technical characteristics.....	Pag. 7
3.2 Dimensions.....	Pag. 7
3.3 Unit's main components.....	Pag. 8
3.4 Back panel description.....	Pag. 9
4. Installation	Pag. 10
4.1 Optical Installation.....	Pag. 10
4.2 Mechanical installation.....	Pag. 11
4.3 Safety chain.....	Pag. 11
4.4 Adjusting unit's tilt.....	Pag. 11
5. Powering up	Pag. 12
5.1 Operating voltage and frequency	Pag. 12
5.2 Connection to mains power.....	Pag. 12
6. Control signal connections	Pag. 14
6.1 Control signal connection by XLR5 plugs	Pag. 14
7. Turning on the projector	Pag. 15
7.1 DMX address of the unit	Pag. 15
8. DMX Chart	Pag. 16
8.1 DMX Chart 16, 10, 6, 5, 1 channels	Pag. 16
9. Display panel functions	Pag. 19
9.1 Quick guide to menu.....	Pag. 19
9.2 Rapid count.....	Pag. 19
9.3 Main functions menu.....	Pag. 20
9.4 Measure (MEAS).....	Pag. 23
9.5 Electronic alignment of the LEDs.....	Pag. 25
9.6 Special functions of the fixture.....	Pag. 26
9.7 Error messages.....	Pag. 26
10. Accessories and spare parts	Pag. 27

11. Maintenance	Pag. 29
11.1 Firmware update.....	Pag. 29
11.2 Periodic cleaning.....	Pag. 29
11.3 Periodic controls.....	Pag. 29
11.4 Fuses.....	Pag. 29
12. F.A.Q. and answers	Pag. 30

Congratulations on having purchased a **Coemar** product. You have assured yourself of a fixture of the highest quality, both in componentry and in the technology used. We renew our invitation to you to complete the service information on the previous page, to expedite any request for service information or spares (in case of problems encountered either during, or subsequent to, installation). This information will assist in providing prompt and accurate advice from your **Coemar** service centre. Following the instructions and procedures outlined in this manual will ensure the maximum efficiency of this product for years to come.

1. Packaging and transportation

1.1 Packaging

Open the packaging and make sure that no part of the equipment has suffered any damage during the transportation. In case of damage to the fixture, contact your carrier and your supplier immediately by telephone, fax or email, and inform them you will formally notify them in writing through registered letter.

Packing list

Ensure the packaging contains:

- 1 Reflection LEDko FullSpectrum 6
- 1 Instruction manual
- 1 Main power plugs

1.2 Transportation

The **LEDko FullSpectrum 6** should be transported in either its original packaging or in an appropriate flight case.

2. General information

2.1 Safety informations

Fire prevention:



1. Never locate the fixture on any flammable surface.
2. Minimum distance from flammable materials: 0,5m.
3. Minimum distance from the closet illuminable surface: 0,5m.
4. Replace any blown or damaged fuse only with those of identical values. Refer to the schematic diagram if there is any doubt.
5. Connect the projector to mains power protected by a thermal magnetic circuit breaker.

Prevention from electric shock:



1. Presence of high voltage inside of the fixture. Insulate the projector from mains supply before opening or performing any function which involves touching the inside of the fixture, including lamp replacement.
2. For the connection to the mains, adhere strictly to the guidelines outlined in this manual.

3. The level of technology of **LEDko FullSpectrum 6** requires the use of specialised personnel for all service applications; refer all work to your authorised **Coemar** service centre.
4. A good earth connection is essential for the proper functioning of the projector. Never connect the fixture if there is no earth connection.
5. Mains cables must not come into contact with other cables.
6. Do not operate the projector with wet hands or in an area where water is present.
7. The fixture must never be located in an exposed position, or in areas of extreme humidity.

Safety:



1. The projector must always be installed with bolts, clamps, or other fixing devices which are suitably rated to support the weight of the projector.
2. Always use a secondary safety fixing device with chain or steel wire of a suitable rating to sustain the weight of the unit in case of failure of the principal fixing point.
3. The external surfaces of the unit, at various points, may reach 60°C. Never handle the unit until at least 10 minutes have elapsed since the LED was turned off.
4. Never install the fixture in an enclosed area lacking sufficient air flow; the room temperature must not exceed 35°C.
5. The projector contains electronic and electrical components which must under no circumstances be in contact with water, oil or any other liquid. Failure to do so will compromise the proper functioning of the projector.

2.2 Warranty conditions

1. The fixture is under warranty for 12 months from the purchase date against factory defections.
2. Damage ought to unskillfulness, inappropriate use, or lack of suggested maintenance are excluded from the warranty.
3. Warranty expires when the projector is opened by unauthorized personnel.
4. Warranty doesn't include the replacement of the fixture.
5. Serial number and model of the fixture are necessary to retrieve informations and assistance from the dealer.

2.3 EC Norms

The projector meets all fundamental applicable EC requirements.

3. Product specifications

3.1 Technical characteristics

Power supply	90-230Vac, 50-60Hz
Maximum current	1.06 A a 230 VaC - 2.71 A a 90 Vac
Power factor	$\text{Cos}\phi = 0.9$
Power consumption	210 watt
Color temperature	RGBW/LA, with pure colour mixing throughout the field and all whites from 2.700 to 6.500 K
Weight (without optic)	6kg - 13.2lbs
Minimum ambient temperature	-20°C / -4°F
Maximum ambient temperature	+35°C / +95°F
IP rating	IP20

3.2 Dimensions

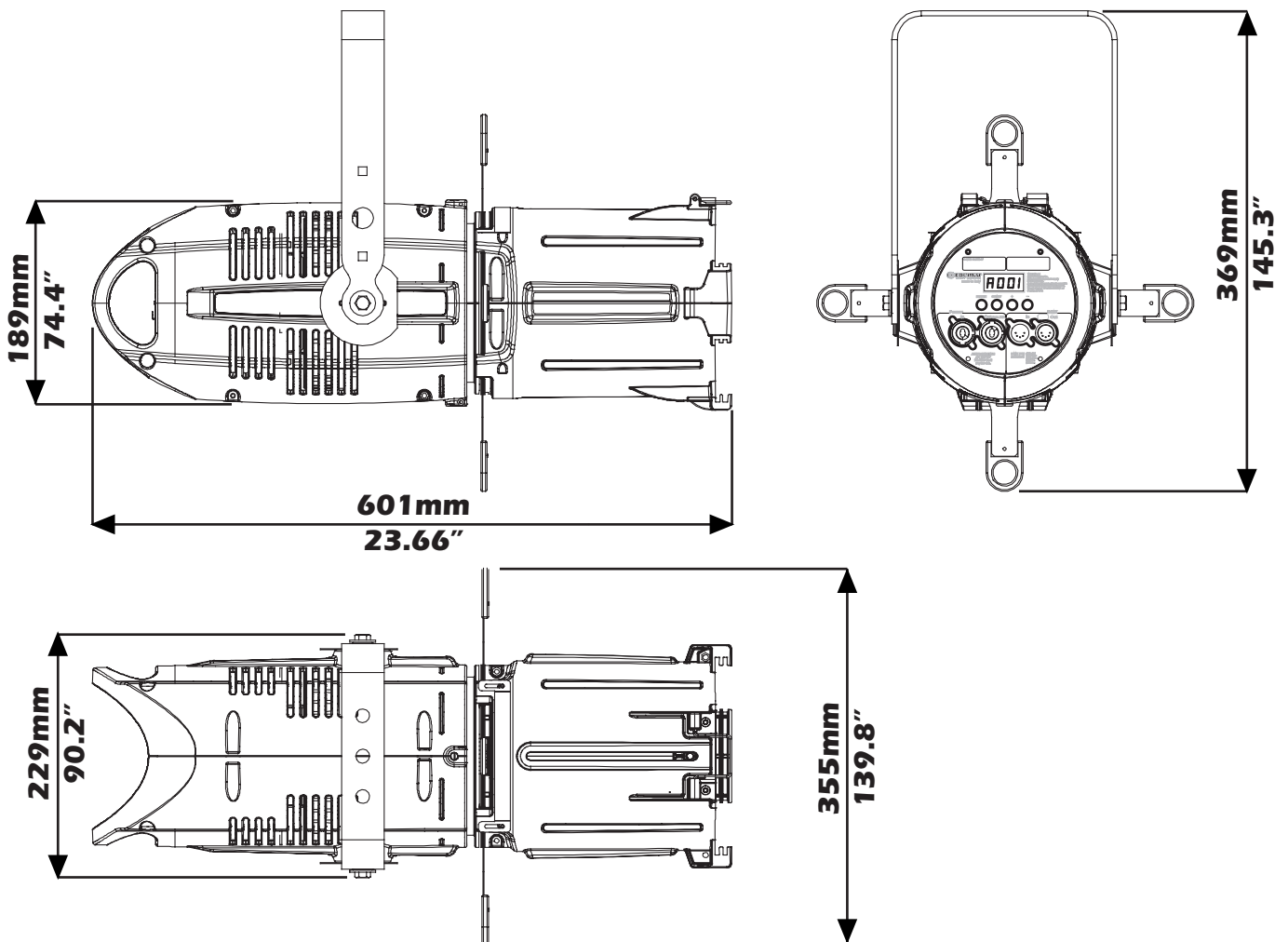

3.3. Unit's main components

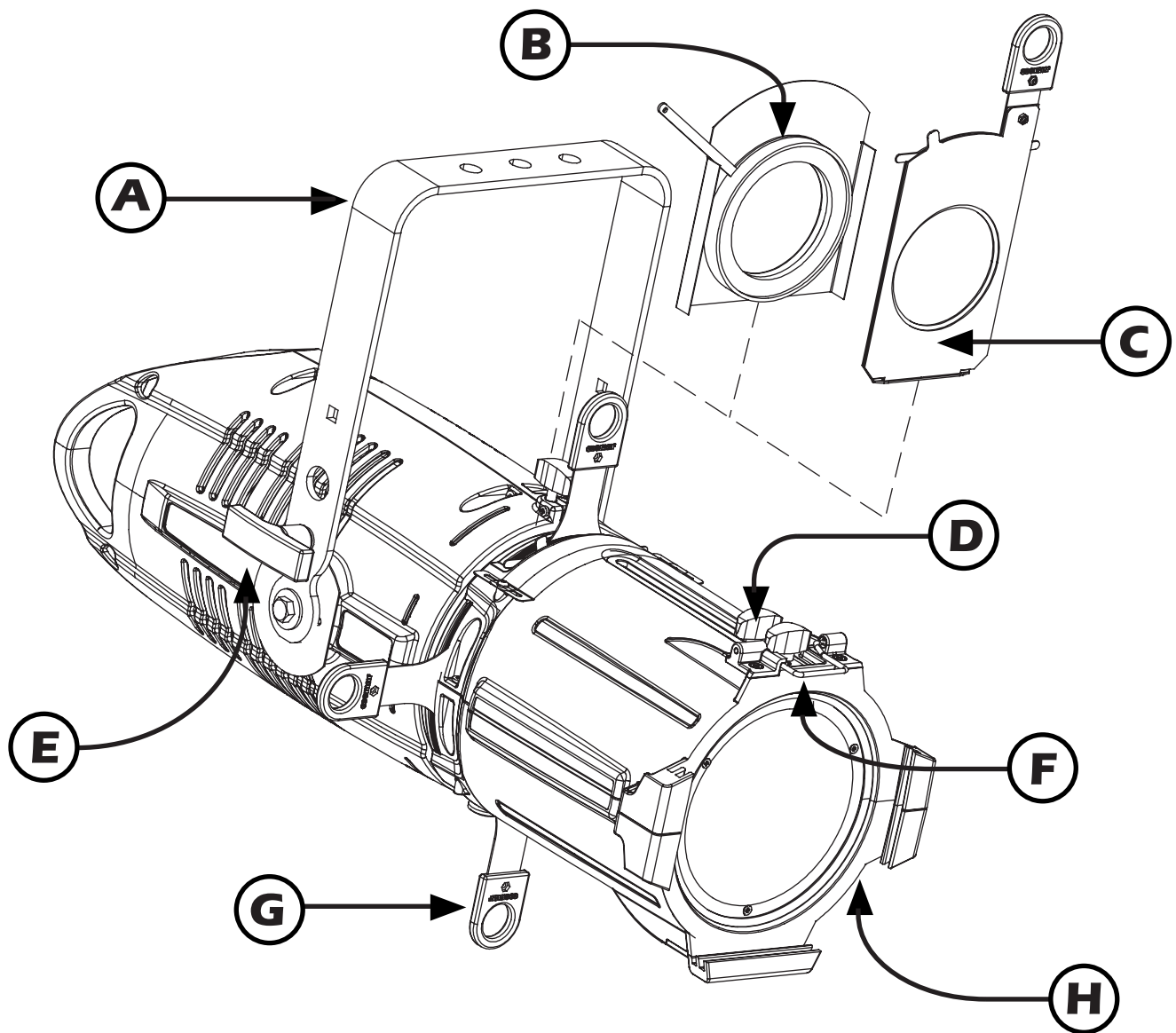

Components description	
A	Adjustable yoke
B	Iris (optional)
C	Gobo holder (optional)
D	Lens adjusting handles
E	Yoke locking handle
F	Gel frame locking spring
G	Profile blade
H	Interchangeable optic

3.4 Back panel description

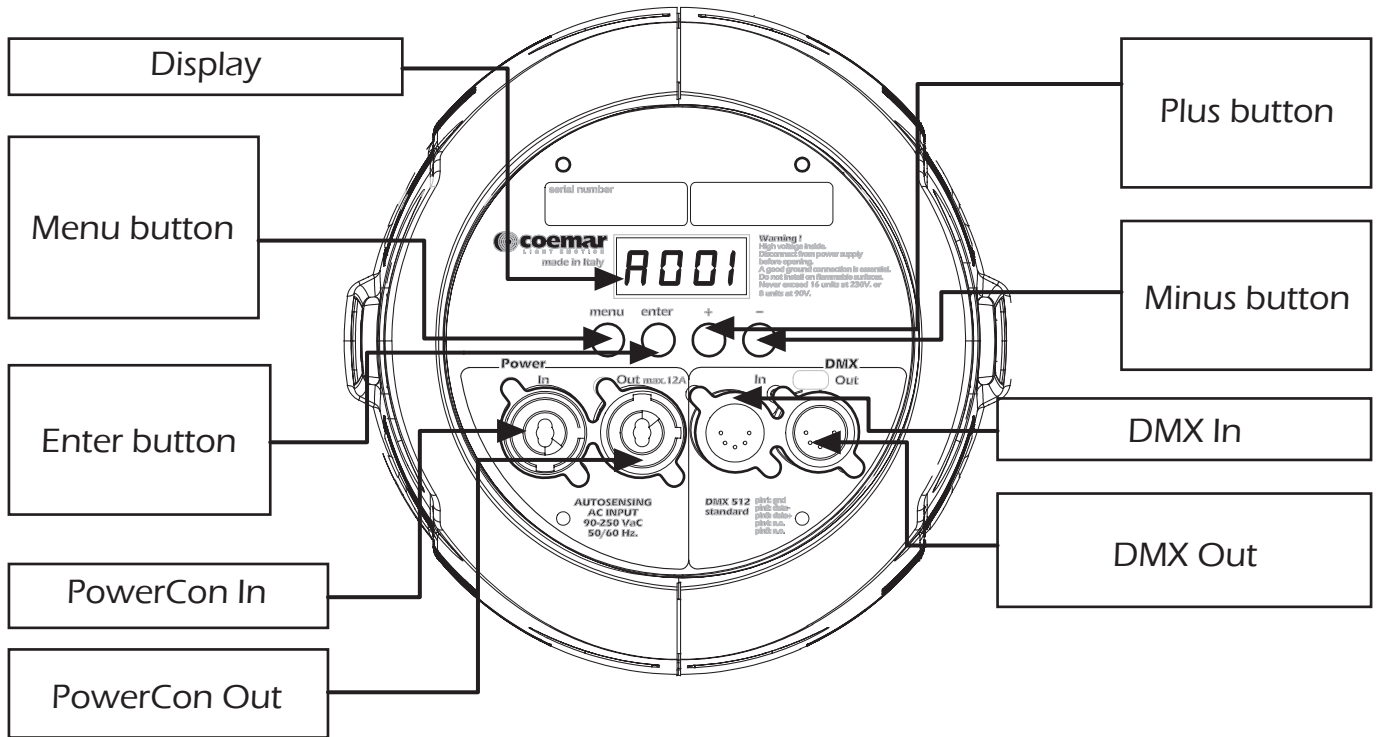

4. Installation

4.1 Optical installation

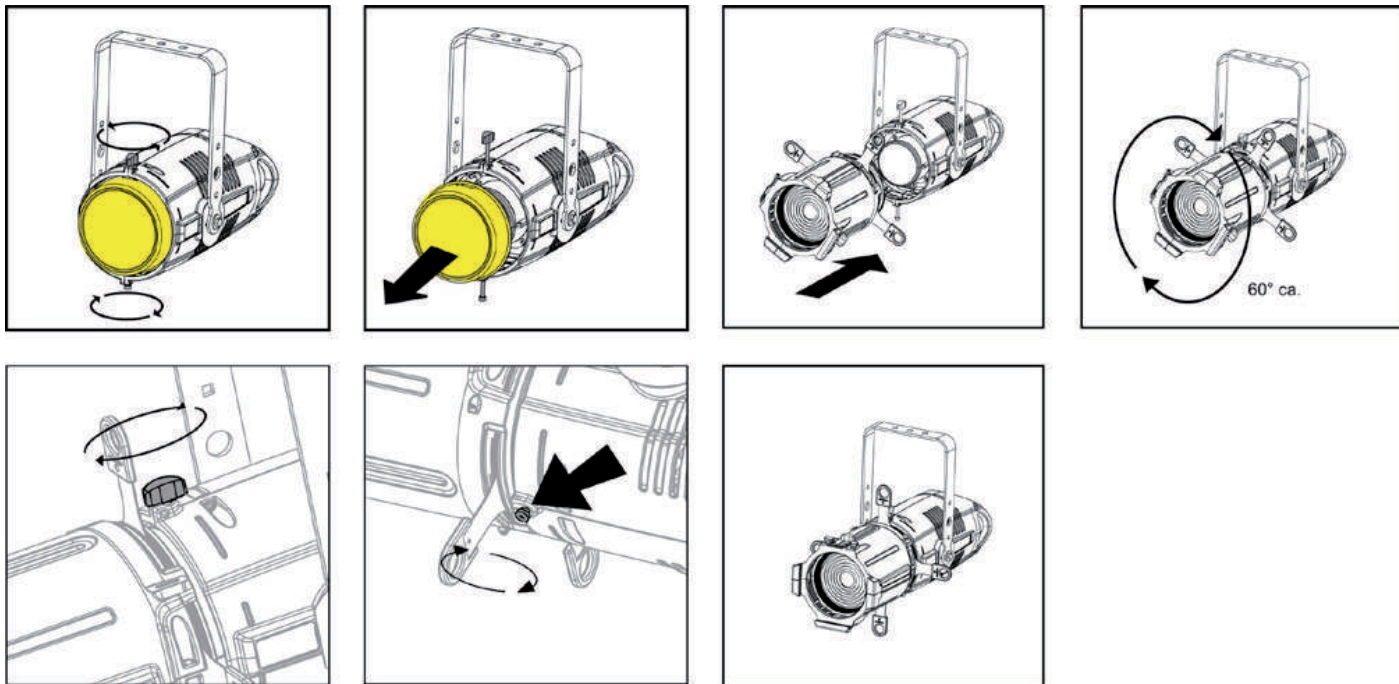

Remove the frontal cap by loosening the upper and lower screws enough to free the cap itself, set the optic's flange tilted about 60°. Insert the optic's flange into the body's receptacle and turn the optic 60° until it is firmly assembled to the projector body, free to rotate but not free to detach itself from the body. Ensure the optic to the body by tightening the two screws previously loosened.

Warning!!

When the protective cap is removed, never lean the fixture facing down.
The front lens can be seriously damaged.

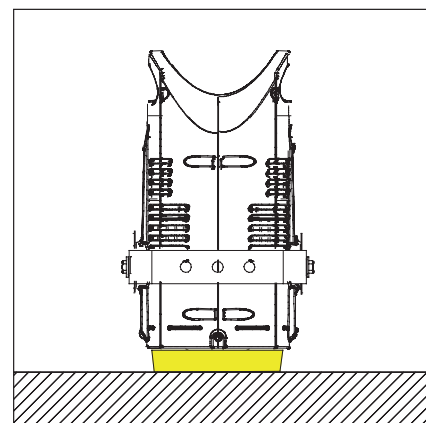
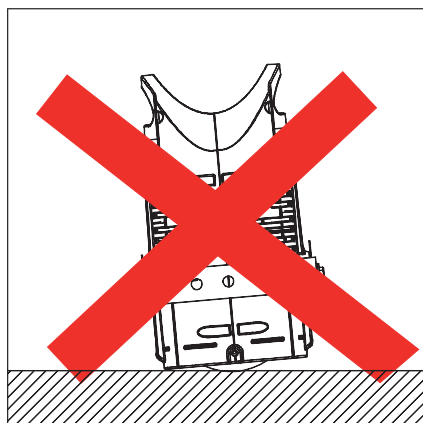
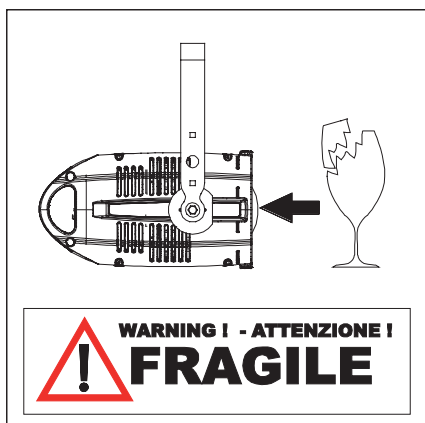

4.2 Mechanical installation

LEDko FullSpectrum 6 may be hung from an appropriate structure in any position or on tripod. If hanging the fixture from a lighting truss or similar, we recommend the use of an appropriate clamp "A", as shown in the following diagram.

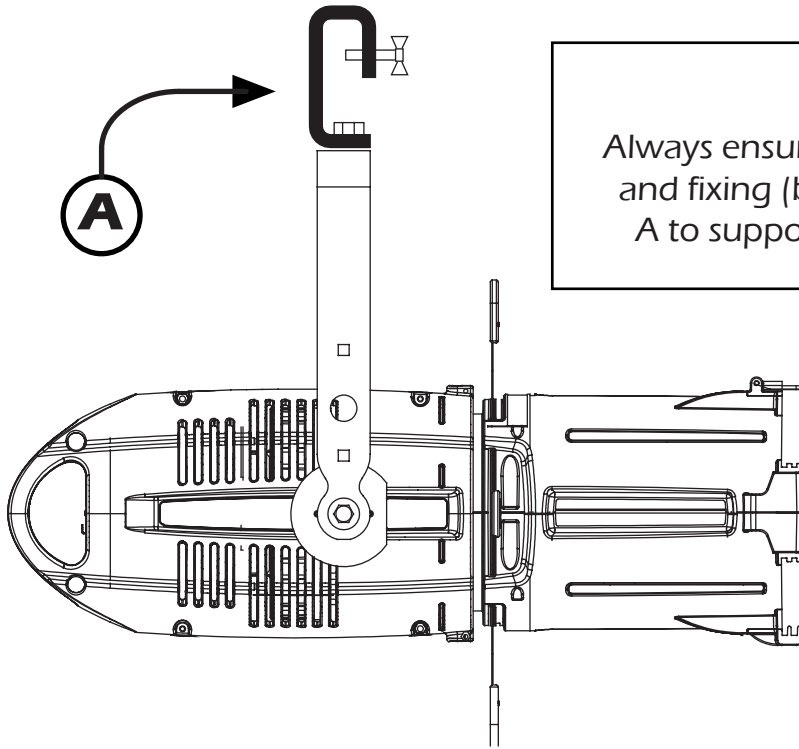

Warning!!

Always ensure that your support structure and fixing (bolts, clamps, etc...) are rated A to support the weight of the fixture.

4.3 Safety chain

When hanging LEDko FullSpectrum 6 it is recommended to use a safety chain, as required by current legislation. The safety chain must pass through the handles of the unit and then attached to the structure.

If using steel cables and chains not **Coemar's** production, make sure they are suitable to support the weight of the unit according to normative UL/ETL (required: the weight of 6 complete devices for at least one hour).

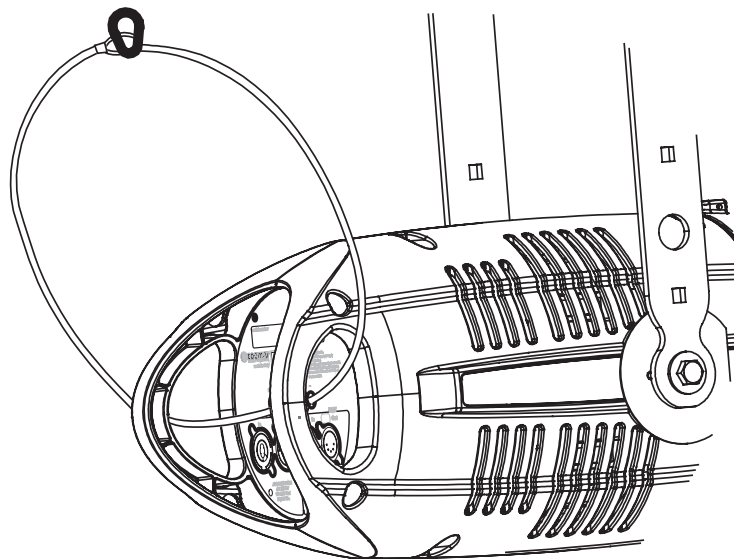

4.4 Adjusting unit's tilt

In order to adjust the tilt of the unit simply loose the side handle adjust the tilt and lock the yoke by tightening the handle again.

5. Powering up

5.1 Operating voltage and frequency

The unit may operate at voltage ranges from 90 to 250V_{aC} at a frequency of 50 or 60 Hz. It is not needed to effect any setup procedures: **LEDko FullSpectrum 6** will automatically adjust its operation to suit any frequency or voltage within this range.

5.2 Connection to mains power

Mains cable characteristics

The mains cable provided is thermally resistant, complying to the most recent International standards.

Note: in case of cable replacement, similar cable with comparable thermal resistant qualities must be used exclusively (cable 3 X 1,5 \varnothing external 10 mm, rated 300/500V, tested to 2 KV, operating temperature -40°C + 180°C, Coemar cod. CV5311).

Connection to mains power

LEDko FullSpectrum 6 is equipped with two power connectors, one as input and one as output, which can be used to feed up to 8 (at 230 V_{aC}) or 4 (90 V_{aC}) fixtures

The max absorption of **LEDko FullSpectrum 6** is reported in the following table:

- 230 V_{aC} 1.06 A constant during normal exercise.
- 90 V_{aC} 2.71 A constant during normal exercise.

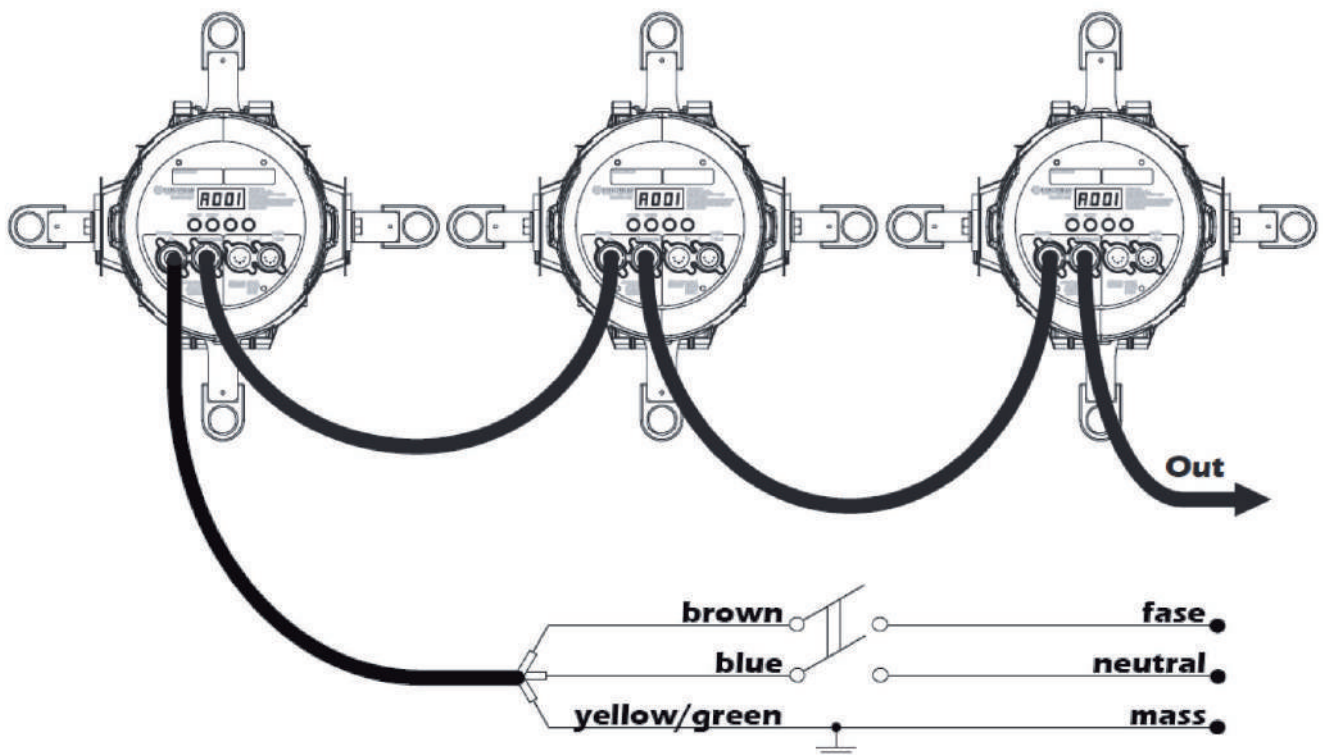

Warning!!

- The use of a thermal/magnetic circuit breaker is recommended. Strict adherence to regulatory norms is strongly recommended.
- **LEDko FullSpectrum 6** should not be powered through a dimmer as this may damage the internal switching power supply.
- Prior to connecting the device to mains power, ensure that the mains characteristics are within the recommended range for the use of **LEDko FullSpectrum 6**.
- All cabling and connections should be carried out by a suitably qualified personnel.

6. Control signal connections

6.1 Control signal connection by XLR5 plugs

The digital control signal is transmitted to the projector via a two pole cable screened in according to the International standards for DMX 512 data transmission. The connection must be serial, using connectors XLR5 male and female located on the back of **LEDko FullSpectrum 6** labelled DMX512 IN e OUT.

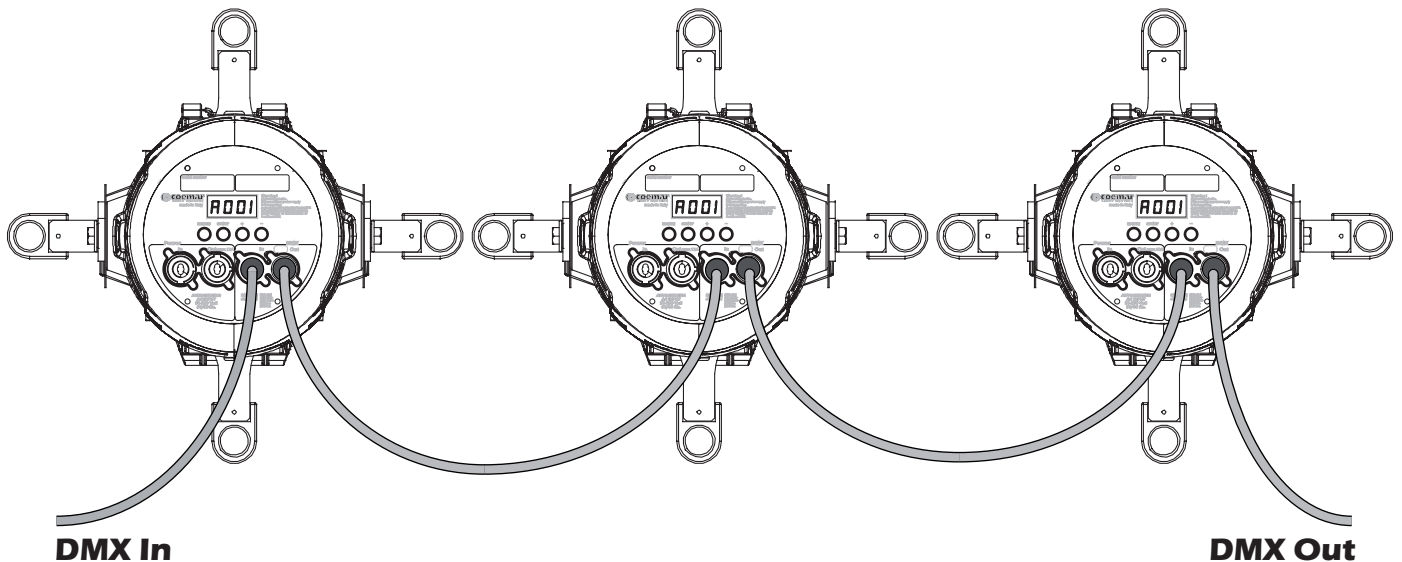

Warning!

Make sure that screening and conductors are not in contact one another or with the metal housing of the connector.

Pin#1 and housing must never be connected to the power supply unit.

7. Turning on the projector

After having followed the preceding steps described, proceed with the power supply and turn on the projector connecting it to the mains power.

The software version installed on the internal microprocessors will be shown on the display, suddenly it will show the current DMX addressing. If the address blinks, it means that the DMX signal has not been received. Check the connection cable and the mixer functioning.

7.1 DMX address of the unit

Each projector can use 16, 10, 6, 5 or 1 address channels for its complete operation and is controlled by a DMX 512 signal.

DMX addressing

When powered up initially, each projector will show A001, which indicates DMX address 001; for example, when set at 16 channels a projector thus addressed will respond to commands of channel 1 to 16 from your DMX 512 controller. A second unit must be addressed as A017, a third one as A033 and so on. The operation must be carried out on every **LEDko FullSpectrum 6** which has an address different from A001.

Altering the DMX address:

1. Press the + or – button until the display shows the required DMX address. The digits on the display will blink to indicate that the variation has not been registered.
2. Press the enter key to confirm your selection. The digits on the display panel will cease to blink and the projector will now respond to the new address.

Note: by holding the + or – button down the scrolling will be faster; thus allowing a faster selection

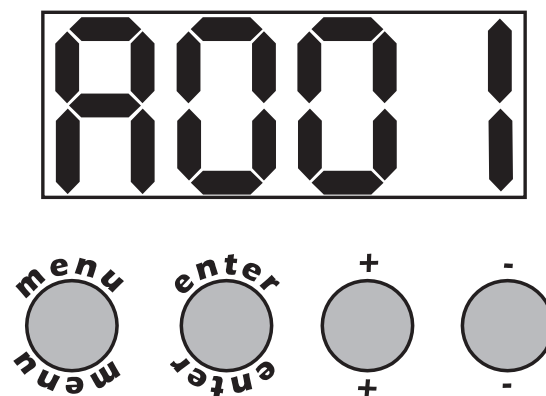

Warning!!

If you alter the DMX address with no DMX signal connected, the digits on the display panel will continue to flash even after you have pressed ENTER button to confirm the address.

8. DMX chart

8.1 DMX Chart 16, 10, 6, 1 channels

channel				function	type of control	effect	decimal		percentage	
16ch	10ch	6ch	1ch							
1	1	-	1 ²	master dimmer	proportional	adjust luminous output intensity from 0 % to 100 %	0	- 255	0%	- 100%
2	2	1	-	red	proportional	proportional control of the color percentage from 0 % to 100 %	0	- 255	0%	- 100%
3	3	2	-	green	proportional	proportional control of the color percentage from 0 % to 100 %	0	- 255	0%	- 100%
4	4	3	-	blue	proportional	proportional control of the color percentage from 0 % to 100 %	0	- 255	0%	- 100%
5	5	4	-	white	proportional	proportional control of the color percentage from 0 % to 100 %	0	- 255	0%	- 100%
6	6	5	-	lime	proportional	proportional control of the color percentage from 0 % to 100 %	0	- 255	0%	- 100%
7	7	6	-	amber	proportional	proportional control of the color percentage from 0 % to 100 %	0	- 255	0%	- 100%
8	8	-	-	strobe effect	step	no effect	0	- 9	0%	- 4%
					proportional	variable speed strobing effect, from slow to fast	10	- 57	4%	- 22%
					step	stop strobe	58	- 59	23%	- 23%
					proportional	sequenced pulsed strobe, slow closing, fast operating (variable speed pulsing, from slow to fast)	60	- 108	24%	- 42%
					step	stop strobe	109	- 110	43%	- 43%
					proportional	sequenced pulsed strobe, fast closing, slow operating (variable speed pulsing, from slow to fast)	111	- 159	44%	- 62%
					step	stop strobe	160	- 161	63%	- 63%
					proportional	random strobe effect with variable speed from slow to fast and synchronised colors	162	- 207	64%	- 81%
					step	stop strobe	208	- 209	82%	- 82%
proportional	random strobe effect with variable speed from slow to fast and non-synchronised colors	210	- 255	82%	- 100%					
9	9	-	-	dimmer fine	proportional	fine dimmer control 16 bit	0	- 255	0%	- 100%
10	10	-	-	special function	step	no effect / park	0	- 71	0%	- 28%
						600 Hz	72	- 84	28%	- 33%
						fan at low-speed	85	- 96	33%	- 38%
						fan at auto-speed	97	- 108	38%	- 42%
					proportional	fan speed control from minimum to maximum	109	- 120	43%	- 47%
					step	no effect	121	- 133	47%	- 52%
						LCD display off	134	- 185	53%	- 73%
						LCD display on	186	- 199	73%	- 78%
						LED control frequency tuning 1000 Hz	200	- 205	78%	- 80%
						LED control frequency tuning 3000Hz	206	- 211	81%	- 83%
						LED control frequency tuning 6000Hz	212	- 217	83%	- 85%
						LED control frequency tuning 8000Hz	218	- 223	85%	- 87%
						LED control frequency tuning 10000Hz	224	- 229	88%	- 90%
						LED control frequency tuning 12000Hz	230	- 235	90%	- 92%
LED control frequency tuning 14000Hz	236	- 241	93%	- 95%						
LED control frequency tuning 16000Hz	242	- 247	95%	- 97%						
LED control frequency tuning 19000Hz	248	- 255	97%	- 100%						
11 ¹	-	-	-	red tone	step	no effect	0	- 9	0%	- 4%
						R823 MEDIUM RED	10	- 70	4%	- 27%
						R25 ORANGE RED (TUNGSTEN)	71	- 132	28%	- 52%
						R24 SCARLET LED (D65)	133	- 194	52%	- 76%
						R0 BASTARD AMBER	195	- 255	76%	- 100%

channel				function	type of control	effect	decimal		percentage				
16ch	10ch	6ch	1ch										
12 ¹	-	-	-	green tone	step	no effect	0	-	9	0%	-	4%	
						R4460 CALCOLOR 60 GREEN	10	-	70	4%	-	27%	
						R2004 DEEP GREEN	71	-	132	28%	-	52%	
						E730 LIGHT GREEN	133	-	194	52%	-	76%	
						E088 LIME GREEN	195	-	255	76%	-	100%	
13 ¹	-	-	-	blue tone	step	no effect	0	-	9	0%	-	4%	
						R2008 STORARO PURPLE	10	-	70	4%	-	27%	
						E5058 FRENCH LILAC	71	-	132	28%	-	52%	
						SOFT PURPLE	133	-	194	52%	-	76%	
						RIPE PURPLE	195	-	255	76%	-	100%	
14	-	-	-	white tone	step	no effect	0	-	9	0%	-	4%	
						2700K	10	-	30	4%	-	12%	
					proportional	porportional value from 2700K to 3200K	31	-	52	12%	-	20%	
						step	3200K	53	-	74	21%	-	29%
					proportional	porportional value from 3200K to 4000K	75	-	96	29%	-	38%	
						step	4000K	97	-	118	38%	-	46%
					proportional	porportional value from 4000K to 5000K	119	-	140	47%	-	55%	
						step	5000K	141	-	162	55%	-	64%
					proportional	porportional value from 5000K to 5600K	163	-	184	64%	-	72%	
						step	5600K	185	-	206	73%	-	81%
					proportional	porportional value from 5600K to 6500K	207	-	228	81%	-	89%	
step	6500K	229	-	255		90%	-	100%					
15 ³	-	-	-	green saturation	step	no effect	0	-	9	0%	-	4%	
						proportional	exalts the green color in the mixing and diminishes the presence of magenta	10	-	123	4%	-	48%
					proportional	step	no effect	124	-	132	49%	-	52%
						proportional	diminishes the presence of green in the mixing and exalts the magenta color	133	-	246	52%	-	96%
						step	no effect	247	-	255	97%	-	100%
16 ⁴	-	-	-	saturation	proportional	the white tone fades to the tone built with the RGBWLA channels	0	-	255	0%	-	100%	
NOTE 1: channels involving 11 - 12 - 13 macro colors can also be obtained by mixing channels 2 - 3 - 4 - 5 - 6 - 7.													
NOTE 2: one channel function mode selects the CCT through the display function menu.													
NOTE 3: the rest position of the green sauration is 128. Diminishing the DMX value augments the presence of the green color. Increasing the DMX value augments the presence of magenta.													
NOTE 4: increasing the value of the Saturation DMX channel the white light will fade to the color selected.													
Projector: Reflection LEDko FullSpectrum RGBWLA					Chart name: DMX 512 function					Software version 1.09 or following			
Chart number: 374					Edition: 1		Date: 12.01.2018						

8.2 DMX Chart 5 channels

channel	function	type of control	effect	decimal		percentage	
5ch							
1	master dimmer	proportional	adjust luminous output intensity from 0 % to 100 %	0	- 255	0%	- 100%
2	white tone	step	no effect	0	- 9	0%	- 4%
			2700K	10	- 30	4%	- 12%
		proportional	porportional value from 2700K to 3200K	31	- 52	12%	- 20%
		step	3200K	53	- 74	21%	- 29%
		proportional	porportional value from 3200K to 4000K	75	- 96	29%	- 38%
		step	4000K	97	- 118	38%	- 46%
		proportional	porportional value from 4000K to 5000K	119	- 140	47%	- 55%
		step	5000K	141	- 162	55%	- 64%
		proportional	porportional value from 5000K to 5600K	163	- 184	64%	- 72%
		step	5600K	185	- 206	73%	- 81%
		proportional	porportional value from 5600K to 6500K	207	- 228	81%	- 89%
step	6500K	229	- 255	90%	- 100%		
3	green saturation	step	no effect	0	- 9	0%	- 4%
		proportional	exalts the green color in the mixing and diminishes the presence of magenta	10	- 123	4%	- 48%
		step	no effect	124	- 132	49%	- 52%
		proportional	diminishes the presence of green in the mixing and exalts the magenta color	133	- 246	52%	- 96%
		step	no effect	247	- 255	97%	- 100%
4	dimmer fine	proportional	fine dimmer control 16 bit	0	- 255	0%	- 100%
5	special function	step	no effect / park	0	- 71	0%	- 28%
			600 Hz	72	- 84	28%	- 33%
			fan at low-speed	85	- 96	33%	- 38%
			fan at auto-speed	97	- 108	38%	- 42%
		proportional	fan speed control from minimum to maximum	109	- 120	43%	- 47%
		step	no effect	121	- 133	47%	- 52%
			LCD display off	134	- 185	53%	- 73%
			LCD display on	186	- 199	73%	- 78%
			LED control frequency tuning 1000 Hz	200	- 205	78%	- 80%
			LED control frequency tuning 3000Hz	206	- 211	81%	- 83%
			LED control frequency tuning 6000Hz	212	- 217	83%	- 85%
			LED control frequency tuning 8000Hz	218	- 223	85%	- 87%
			LED control frequency tuning 10000Hz	224	- 229	88%	- 90%
			LED control frequency tuning 12000Hz	230	- 235	90%	- 92%
			LED control frequency tuning 14000Hz	236	- 241	93%	- 95%
LED control frequency tuning 16000Hz	242		- 247	95%	- 97%		
LED control frequency tuning 19000Hz	248	- 255	97%	- 100%			

NOTE 1: The rest position of green saturation is 128. Diminishing the DMX value augments the presence of the green color. Increasing the DMX value augments the presence of magenta.

Projector: Reflection LEDko FullSpectrum RGBWLA	Chart name: DMX 512 function	Software version 1.09 or following
Chart number: 374	Edition: 1	Date: 12.01.2018

9. Display panel functions

9.1 Quick guide to menu

To access the functions menus just press the MENU button. Then press + or – buttons to scroll the pages and press the ENTER button to access to any other function.

By suitably using all the functions of **LEDko FullSpectrum 6**, which can be activated through its display panel, it is possible to change some of the parameters and to add some functions. Changing the preset settings made by **Coemar** can vary the functions of the projector so that it will respond differently to the controller; therefore carefully read about the functions described here before carrying out any possible selection.

9.2 Rapid count

Through the display panel of **LEDko FullSpectrum 6** it is possible to quickly change the various numbers displayed for the different functions in the following 3 manners:

1. Pressing the + or – buttons will cause the count to be quicker.
2. Pressing first + and then – and then holding them down simultaneously will cause the numbers to jump to the highest value.
3. Pressing first – and then + and then holding them down simultaneously will cause the number to jump to the lowest value.

9.3 Main functions menu

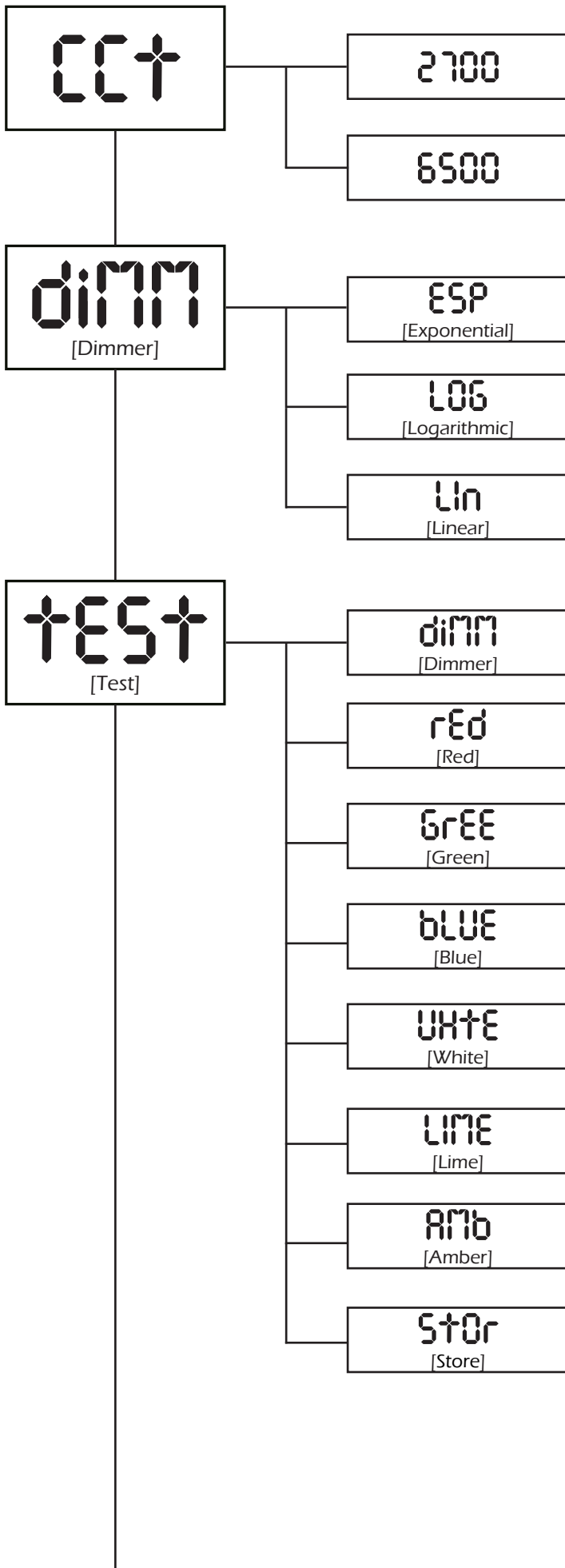

CCT:

This channel offers a preset library of various white CCT from a range 2700 K up to 6500 K by 100 K steps, manually selectable without the need of a DMX console;

Dimmer:

It allows the selection of different dimmer curves: exponential (default), logarithmic and linear;

Test:

Enter this channel to manually set and configure the following settings:

- **Dimmer:** to change the luminous intensity;
- **Colors:** it allows to set the color intensity for each and every single color (Red, Green, Blue, White, Lime and Amber);
- **Store:** enter this channel to store the settings as previously modified. The stored values will remain in memory even once the fixture is switched off.

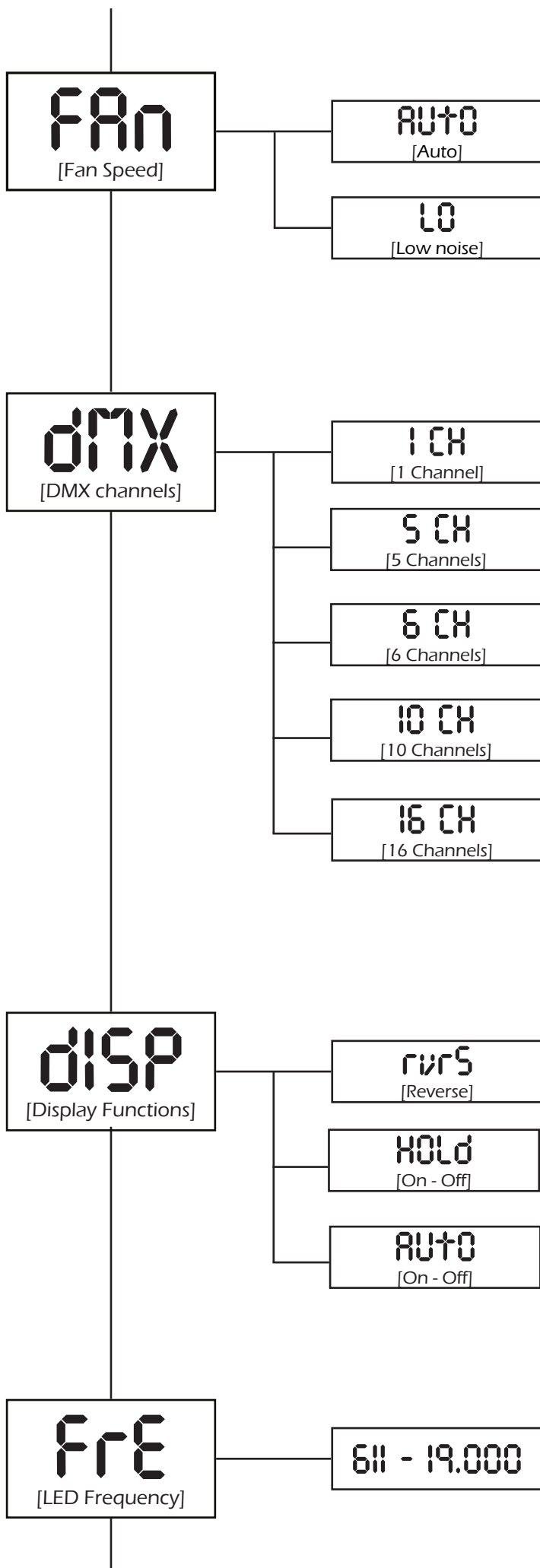

Fan Speed:

- **Auto:** under this setting the fan speed varies based on the overall temperature of the fixture to guarantee the maximum output possible;
- **Low noise:** this setting will keep the speed of the fan at the minimum level while the light output will decrease in case of overheat.

DMX channels:

Shows the DMX mode and number of channels selectable;

Display Functions:

- **Reverse:** it allows to turn by 180° the reading of the display;
- **Hold:** locks the keys. Press any key for 5 seconds to unlock;
- **Auto:** it allows to turn off the display after 6 seconds.

LED Frequency:

It allows to set the PWM frequency from 611 to 19.000 Hz. A low PWM frequency is recommended to get the best dimming curve, whilst a higher PWM frequency should be selected to ensure flicker-free operations of the fixture;

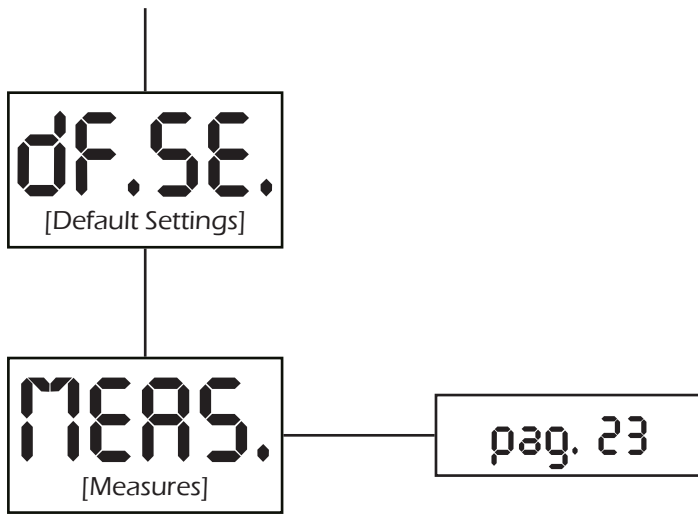
**Default Settings:**

Allows to restore the factory default of the fixture, with exception of DMX address and LED alignment;

Measures:

Allows to read all the parameters: LED and board temperatures, fan level, DMX ratio, DMX, alarms, channels value and software version.

9.4 Measure (MEAS)

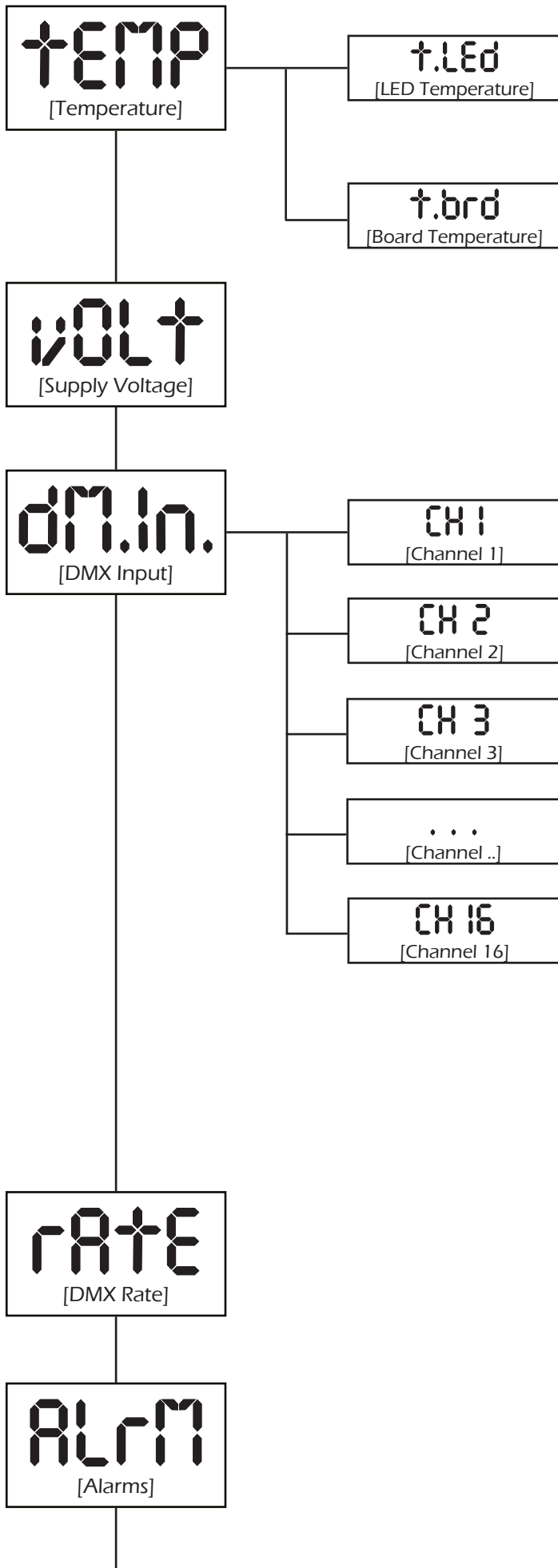

Temperature:

Shows the current temperature values:

- **LED:** shows the LED module temperature;
- **Board:** shows the electronic board temperature;

Volt:

Shows the power supply voltage;

DMX Input:

Shows the value of the DMX channels received by the fixture on every channel that the fixture occupies on the line;

Rate:

Shows the refresh rate of the DMX signal sent by the console;

Alarm:

This menu eventually shows the alarm statuses if there is any;

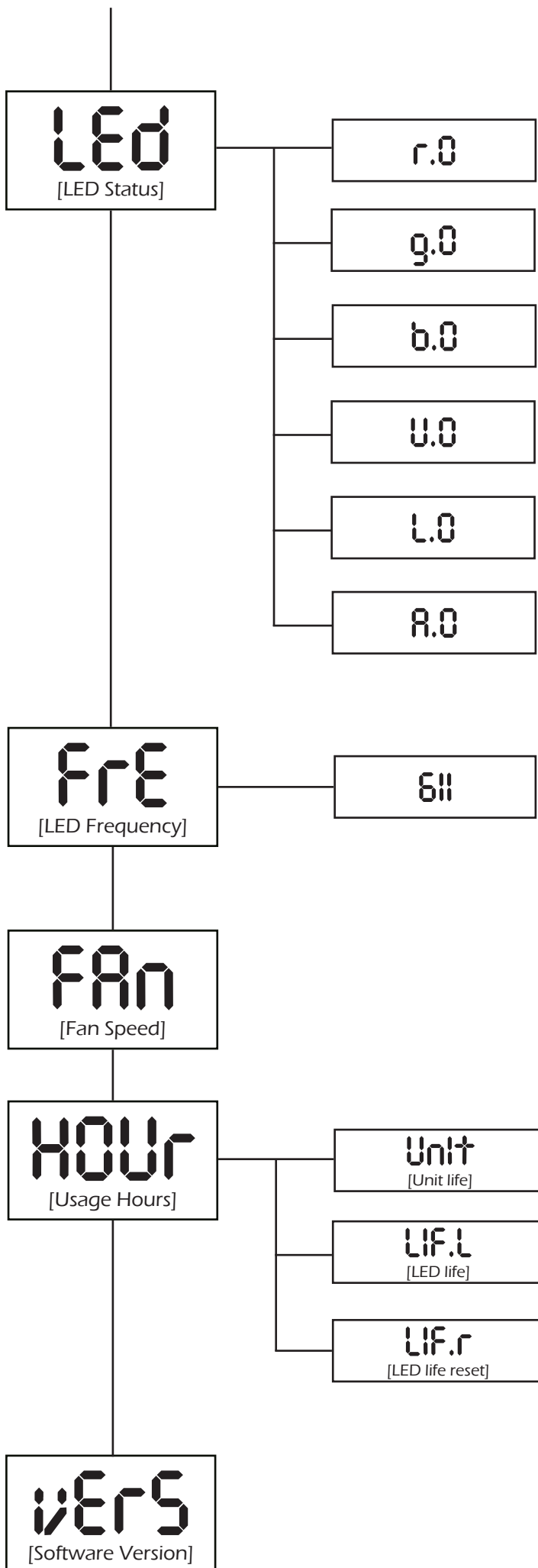

LED:

Shows the percentage value of the LED status;

Fre:

Shows the PWM frequency of the LED (611 Hz as default);

Fan speed:

Shows the percentage fan usage;

Usage hours:

Shows the hour counter of the fixture:

- **Unit:** shows the overall hours of life of the fixture;
- **LED life:** shows the overall LED module life;
- **LED life reset:** shows the overall LED module life currently installed.

Note: this items can be reset in case of LED module replacement;

Software version:

Shows the software version currently installed in the fixture.

9.5 Electronic alignment of the LEDs

The display panel of **LEDko FullSpectrum 6** allows the electronic alignment of the LEDs, this procedure is performed by **Coemar** at the time of testing, this procedure may be useful for special effects or in case of replacement of internal components (PCBs, LEDs, etc...).

Altering the settings made by **Coemar** may radically alter the operation of the projector's functions.

Carefully read the following prior to attempting any changes.

Warning!!

This chapter should be considered for the exclusive use of technicians and qualified personnel.

Warning!!

This menu can only be accessed in the **df.SE**. [Default Settings] menu by pressing at the same time **ENTER** and **MENU** buttons. This menu shall be accessed only by authorized technicians.

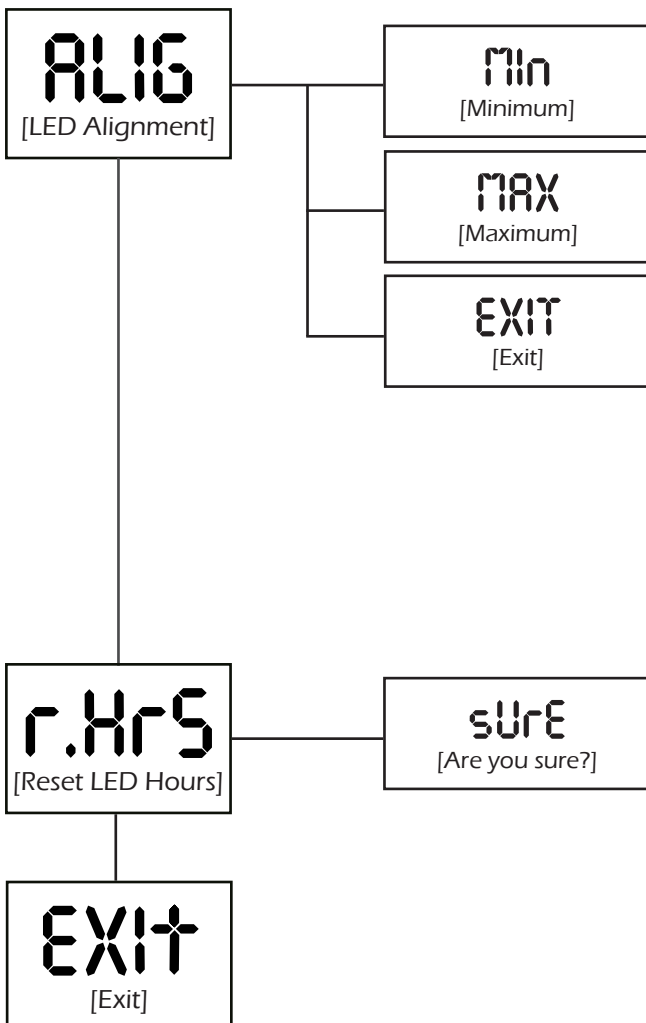

LED alignment:

This item allows to align the minimum and the maximum level of intensity of the LEDs:

- **Minimum:** raise or lowers the minimum intensity to level the dimming between the fixtures;
- **Maximum:** aligns the maximum output level between each fixture;
- **Exit:** Exits the menu and stores the changes;

Reset hours:

Allows to erase the hours of operation of the LED module in case of replacement;

Exit:

Exits the menu and stores the new alignment parameters.

9.6 Special functions of the fixture

Storing the DMX signal

To use the fixture without an active DMX console it is possible to store the DMX settings in two ways:

- Through the **TEST** menu;
- Disconnecting the DMX signal when the fixture is on. When the signal is unconnected the fixtures stores the signal;

Automatic fan standby

To decrease the noise and the power consumption the cooling fan turns off after 10 minutes of fixture inactivity.

9.7 Error messages

If a malfunction occurs, **LEDko FullSpectrum 6** has a self-diagnostic system that will show the error message on the display. The following table will explain in detail the most common errors. If, despite of suggested intervention, the problem persists, call the **Coemar** Service Center.

Error code	Description
nOAL [No Alarm]	No Alarm The projector self-diagnostic routine didn't find any issue.
dTEr [Data Error]	Data error Initial data loading has failed the projector loaded the default data settings: restart the fixture again, and if the error persists contact the Coemar assistance center.
AdEr [Address Error]	Address error The projector does not receive all channels of DMX needs to function properly. Check the DMX address indicated on the display and the number of channels generated by the mixer control. We recall in this connection that some controllers do not generate all the 512 channels.
LEd [Data Error]	LED error Auto diagnostic routine found that the LED module may damaged, contact Coemar assistance for the module replacement. IMPORTANT: To ensure the sensor is giving correct readings, set the LED to the maximum light output level.

10. Accessories and spare parts

LEDko FullSpectrum 6 is a very versatile fixture, optional accessories for its customization are available under request:

Accessory name	Code
Front barrel for lens tube with burnished blades	BC10011A200
Profile 5°, lens tube	BC10011A041
Profile 10°, lens tube	BC10011A042
Profile 14°, lens tube	BC10011A023
Profile 19°, lens tube	BC10011A012
Profile 26°, lens tube	BC10011A013
Profile 36°, lens tube	BC10011A015
Profile 50°, lens tube	BC10011A016
Profile 70°, lens tube	BC10011A024
Profile 90°, lens tube	BC10011A025
Profile Zoom 15°- 35°	BC10011A017
Profile Zoom 25°- 50°	BC10011A019
Profile Zoom 28°- 40°	BC10011A003
Soft Profile Fresnel Zoom 14°- 40°	BC10011A002
Soft Profile PC Zoom 11°- 38°	BC10011A001
4 leaf barndoor	ACO4202
Gobo frame holder	BC10011A006
Iris	BC10011A010
Donut (190.5 mm)	BC10011A028
Half Top Hat (190.5 mm)	BC10011A027
Top Hat (190.5 mm)	BC10011A029
Color Frame Holder (190 mm)	BC10011A040
Donut (185 mm)	BC10011A036
Half Top Hat (185 mm)	BC10011A035
Top Hat (185 mm)	BC10011A037
Color Frame Holder (185 mm)	ACO4204

Donut (159 mm)	BC10011A032
Half Top Hat (159 mm)	BC10011A031
Top Hat (159 mm)	BC10011A033
Colour Frame Holder (159 mm)	BC10011A021
(Gobo Slot) Glass template holder (93.6 mm)	BC10011A030
Hook clamp, 48-51 mm, max. load 20 Kg.	BC10011A047
Light clamp silver, 48-51 mm, max. load 75 Kg.	BC10011A045
Light clamp black, 48-51 mm, max. load 75 Kg.	BC10011A046
Clamp silver, flat 13-30 mm/ø 15-50 mm, max. load 20 Kg.	BC10011A043
Clamp black, flat 13-30 mm/ø 15-50 mm, max. load 20 Kg.	BC10011A044

All the components of **LEDko FullSpectrum 6** are available as spare parts from your Coemar dealer or Service. Accurate description of the fixture, model number and type will assist us in providing for your requirements in an efficient and effective manner.

11. Maintenance

11.1 Firmware update

The firmware of **LEDko FullSpectrum 6** can be updated through the RDM protocol (ANSI E1.20). Contact Coemar assistance to receive the software and the device updater.

11.2 Periodic cleaning

Lenses

Even a thin layer of dust can reduce the luminous output and alter the consistency of the beam. Regularly clean all filters and lenses using a soft cotton cloth, dampened with a special lens cleaning solution.

Cleaning of the unit

Use a soft brush or a common vacuum cleaner or a source of compressed air for removing dust. For the cleaning of the housing use a soft cloth and a non-aggressive cleaner. Check that the internal fans and heat exchanger must be perfectly clean.

11.3 Periodic controls

Mechanical components

Check the correct working of the mechanical parts and, if needed, replace them. Make sure the projector is not mechanically damaged. If necessary, replace the worn parts.

Electrical components

Check all electrical connections, in particular for correct grounding and correct attachment of all extractable connectors. Press the connectors if necessary and reposition as before.

11.4 Fuses

LEDko FullSpectrum 6 has an automatic fuse that in most cases does not need to be replaced.

12. F.A.Q. and answers

The following list shows common issues that may be simply solved. If issues persist, the unit must be repaired by a qualified personnel or just contact your **Coemar** service near you.

Question	Possible solution
LEDko FullSpectrum 6 does not emit light	Projector not powered on: <ul style="list-style-type: none">• Make sure the power cord is plugged in or test the input voltage; Wrong DMX address: <ul style="list-style-type: none">• Check the DMX Address setting and the output signal of the controller;
LEDko FullSpectrum 6 is not responding to DMX signal	DMX signal may not reach LEDko FullSpectrum 6: <ul style="list-style-type: none">• Inspect the cable connection, correct poor connections or inefficient repair or replace damaged cables;• Check DMX address of the unit;

User notes

A series of horizontal dotted lines for writing notes.



Information on disposal of the equipment

The equipment at the end of its useful life must be disposed of at an appropriate recycling center for waste electrical and electronic equipment. The treatment and disposal of environmentally friendly, helps prevent potential negative environmental and health and promote the reuse and / or recycling of materials making up the equipment. Illegal disposal by the user includes the application of administrative sanctions provided by law.



Coemar Lighting s.r.l.

Via Carpenedolo 90
46043 Castiglione delle Stiviere, Mantova, Italy
phone. +39 0376/1514412 - fax +39 0376/1514380
info@coemar.com

Coemar reserves the right to effect modifications without notification