

StripLite Led RGBW

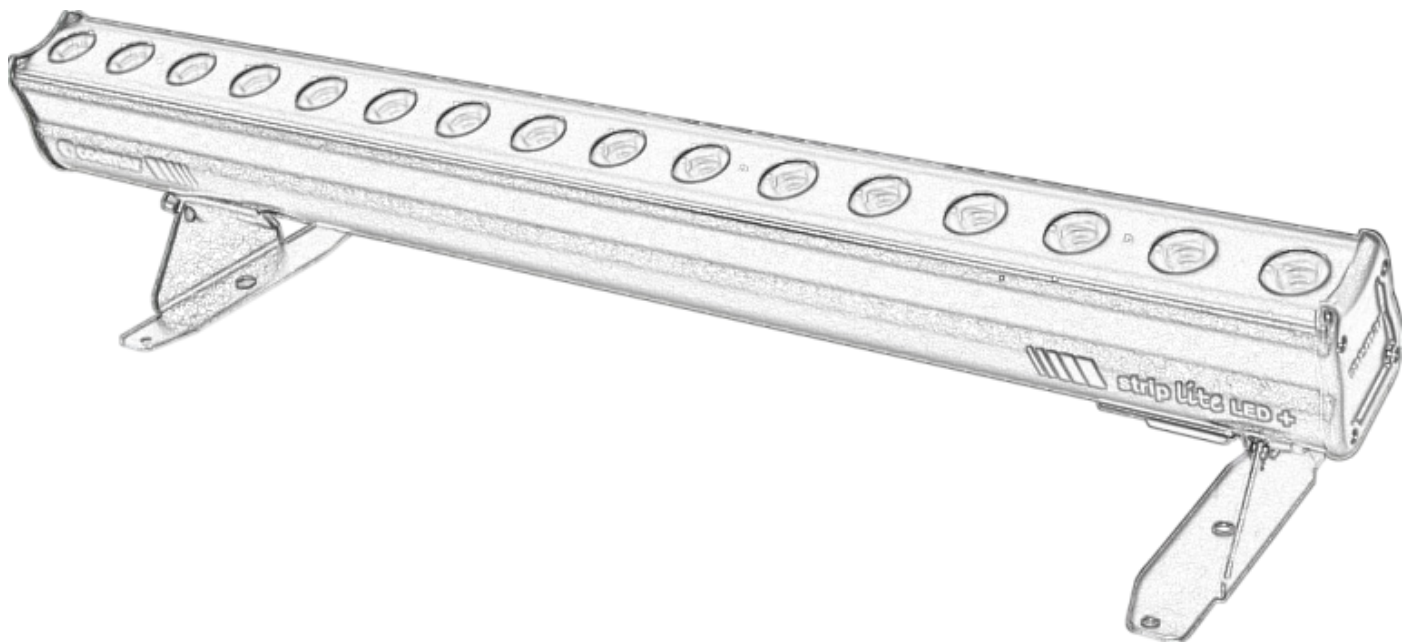

StripLite Led RGBW

Serial Number:

.....

Purchase date:

.....

Dealer:

.....

Address:

.....

Suburb:

.....

Country:

.....

Phone / Fax:

.....

Please note in the space provided above the relative service information of the model and the retailer from whom you purchased your **StripLite Led RGBW**: this information will assist us in providing spare parts, repairs or in answering any technical enquiries with the utmost speed and accuracy.

WARNING: the security of the fixture is granted only if these instructions are strictly followed; therefore it is absolutely necessary to keep this manual.

Index

1. Packaging and transportation	Pag. 4
1.1 Packaging.....	Pag. 4
1.2 Transportation.....	Pag. 4
2. General Information	Pag. 4
2.1 Important safety information.....	Pag. 4
2.2 Warranty conditions.....	Pag. 5
2.3 EC Norms.....	Pag. 5
3. Product specifications	Pag. 6
3.1 Technical characteristics.....	Pag. 6
3.2 Dimensions.....	Pag. 6
3.3 Unit's main components.....	Pag. 7
3.4 Back panel description.....	Pag. 7
4. Installation	Pag. 8
4.1 Mechanical installation.....	Pag. 8
4.2 Adjusting unit's tilt.....	Pag. 8
5. Powering up	Pag. 9
5.1 Operating voltage and frequency.....	Pag. 9
5.2 Connection to mains power.....	Pag. 9
5.3 Supply cable characteristics.....	Pag. 9
6. Control signal connections	Pag. 10
6.1 Control signal connection by XLR5 plugs.....	Pag. 10
7. Turning on the projector	Pag. 11
7.1 DMX address of the unit.....	Pag. 11
8. DMX Chart	Pag. 12
8.1 DMX Chart 14, 8, 4, 1 channels.....	Pag. 12
8.2 DMX Chart 7 channels.....	Pag. 15
9. Display panel functions	Pag. 16
9.1 Quick guide to menu.....	Pag. 16
9.2 Rapid count.....	Pag. 16
9.3 Main functions menu.....	Pag. 17
9.4 Measure (MEAS).....	Pag. 19
9.5 Electronic alignment of the LEDs.....	Pag. 21
9.6 Special functions of the fixture.....	Pag. 22
9.7 Error messages.....	Pag. 22
10. Accessories and spare parts	Pag. 23
11. Maintenance	Pag. 23
11.1 Firmware update.....	Pag. 23
11.2 Periodic cleaning.....	Pag. 23
11.3 Periodic controls.....	Pag. 23
11.4 Fuses.....	Pag. 23
12. F.A.Q. and answers	Pag. 24

Congratulations on having purchased a **Coemar** product. You have assured yourself of a fixture of the highest quality, both in componentry and in the technology used. We renew our invitation to you to complete the service information on the previous page, to expedite any request for service information or spares (in case of problems encountered either during, or subsequent to, installation). This information will assist in providing prompt and accurate advice from your **Coemar** service centre. Following the instructions and procedures outlined in this manual will ensure the maximum efficiency of this product for years to come.

1. Packaging and transportation

1.1 Packaging

Open the packaging and make sure that no part of the equipment has suffered any damage during the transportation. In case of damage to the fixture, contact your carrier and your supplier immediately by telephone, fax or e-mail, and inform them you will formally notify them in writing through registered letter.

Packing list

Make sure the packaging contains:

- 1 StripLite Led RGBW**
- 1 Instruction manual**
- 1 Main power plugs**

1.2 Transportation

The **StripLite Led RGBW** must be transported exclusively in its original packaging or in an appropriate flight case.

2. General information

2.1 Important Safety information

Fire prevention:



1. Never locate the fixture on any flammable surface.
2. Minimum distance from flammable materials: 0,5 m.
3. Minimum distance from the closet illuminable surface: 0,5 m.
4. Replace any blown or damaged fuse only with those of identical values. Refer to the schematic diagram if there is any doubt.
5. Connect the projector to mains power protected by a thermal magnetic circuit breaker.

Prevention from electric shock:



1. Presence of high voltage inside of the fixture. Insulate the projector from mains supply before opening or performing any function which involves touching the inside of the fixture, including lamp replacement.
2. For the connection to the mains, adhere strictly to the guidelines outlined in this manual.
3. The level of technology of **StripLite Led RGBW** requires the use of specialised personnel for all service applications; refer all work to your authorised **Coemar** service centre.
4. A good earth connection is essential for the proper functioning of the projector. Never connect the fixture if there is no earth connection.
5. Mains cables must not come into contact with other cables.
6. Do not operate the projector with wet hands or in an area where water is present.
7. The fixture must never be located in an exposed position, or in areas of extreme humidity.

Safety:

1. The projector must always be installed with bolts, clamps, or other fixing devices which are suitably rated to support the weight of the projector.
 2. Always use a secondary safety fixing device with chain or steel wire of a suitable rating to sustain the weight of the unit in case of failure of the principal fixing point.
 3. The external surfaces of the unit, at various points, may reach 60°C. Never handle the unit until at least 10 minutes have elapsed since the LED was turned off.
 4. Never install the fixture in an enclosed area lacking sufficient air flow; the room temperature must not exceed 35°C.
 5. The projector contains electronic and electrical components which must under no circumstances be in contact with water, oil or any other liquid. Failure to do so will compromise the proper functioning of the projector.
-

2.2 Warranty conditions

1. The fixture is under warranty for 36 months from the purchase date against factory defections.
 2. Damage ought to unskillfulness, inappropriate use, or lack of suggested maintenance are excluded from the warranty.
 3. Warranty expires when the projector is opened by unauthorized personnel.
 4. Warranty doesn't include the replacement of the fixture.
 5. Serial number and model of the fixture are necessary to retrieve informations and assistance from the dealer.
-

2.3 EC norms

The projector meets all fundamental applicable EC requirements.

3. Product specifications

3.1 Technical characteristics

Power supply	90-264 V, auto-sensing, 50/60 Hz
Maximum	0.37 A a 230 V - 0.73 A a 115 V
Phase coefficient	$\text{Cos}\varphi = 0.95$
Light source power	80 W
Color temperature excursion	RGBW, with pure color mixing throughout the field and all whites from 2.700 to 10.000 K
Weight	8.7 Kg - 19.2 lbs.
Maximum environment temperature	35°C
IP rating	20 or 65

3.2 Dimensions

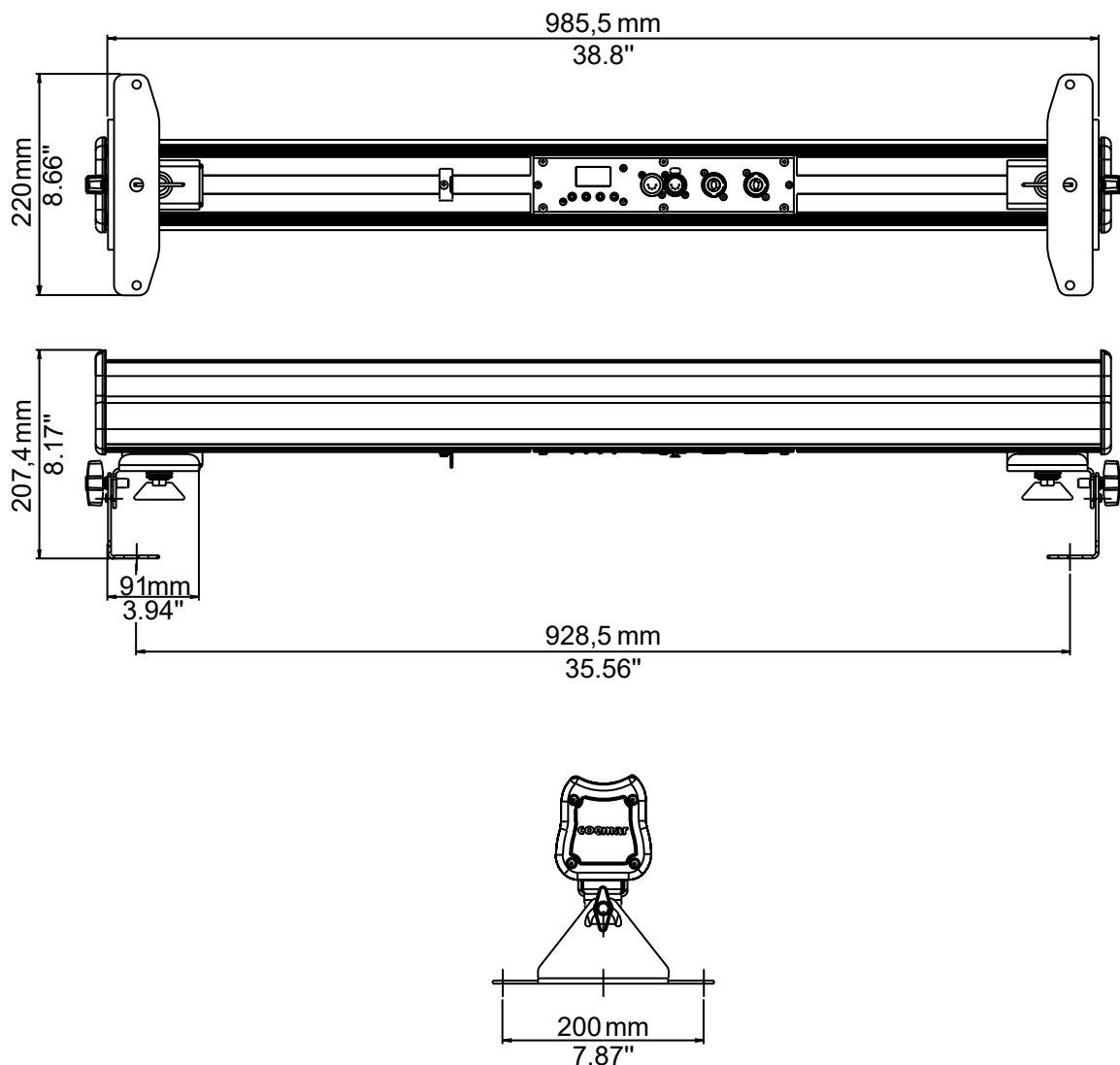

3.3 Unit's main components

Components description	
A	Locking knobs
B	Feet
C	Front panel

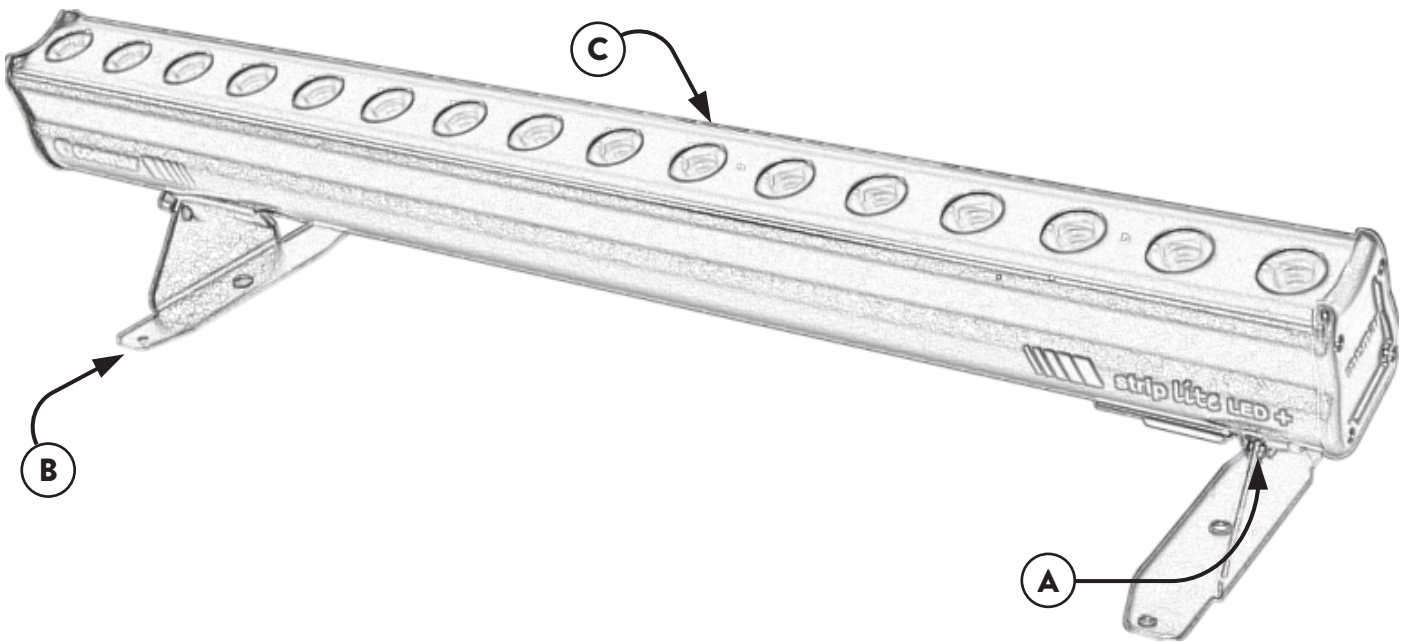

3.4 Back panel description

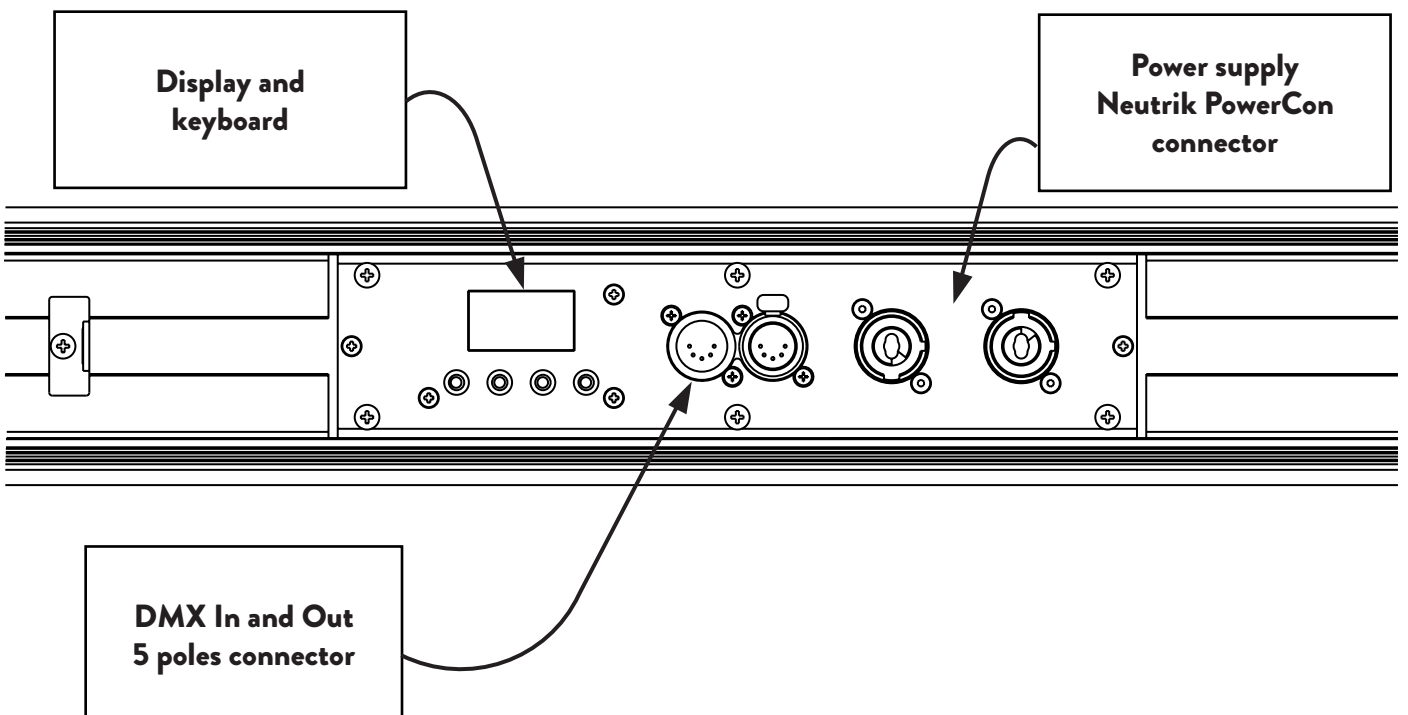

4. Installation

4.1 Mechanical installation

StripLite Led RGBW may be hung from an appropriate structure in any position or on tripod. If hanging the fixture from a lighting truss or similar, we recommend the use of an appropriate clamp “A”, as shown in the following diagram.

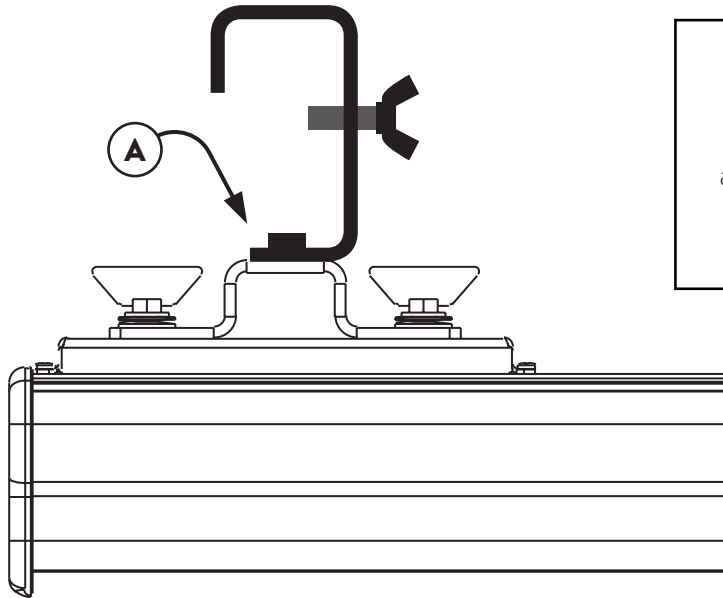

Warning!!

Always ensure that your support structure and fixing (bolts, clamps, etc...) are rated to support the weight of the fixture.

4.2 Adjusting unit's tilt

In order to adjust the tilt of the unit simply loose the side handle, adjust the tilt and lock the yoke by tightening the handle again.

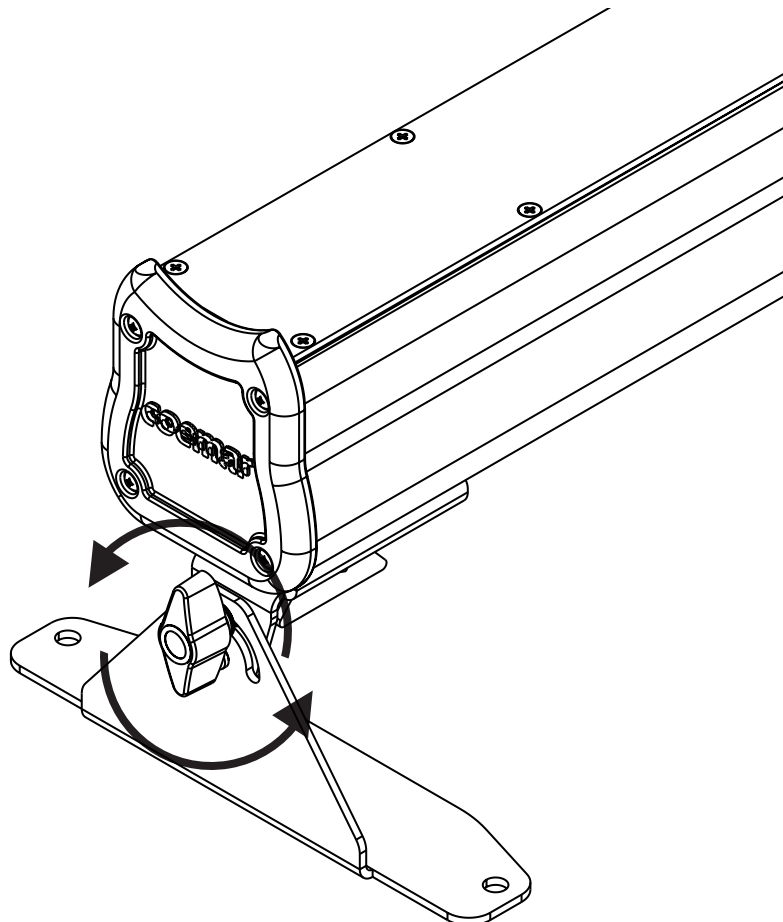

5. Powering up

5.1 Operating voltage and frequency

The unit may operate at voltage ranges from 90 to 264 V at a frequency of 50 or 60 Hz. It is not needed to effect any setup procedures: **StripLite Led RGBW** will automatically adjust its operation to suit any frequency or voltage within this range.

5.2 Connection to mains power

Mains cable characteristics

The mains cable provided is thermally resistant, complying to the most recent International standards.

Note: in case of cable replacement, similar cable with comparable thermal resistant qualities must be used exclusively (cable 3 X 1,5 \varnothing external 10 mm, rated 300/500V, tested to 2 KV, operating temperature -40°C +180°C, **Coemar** cod. CV5311).

Connection to mains power

StripLite Led RGBW is equipped with two power connectors, one as input and one as output, which can be used to feed up to 10 (at 230 V) or 5 (115 V) fixtures.

The max absorption of **StripLite Led RGBW** is reported in the following table:

- 230 V, 0.37 A constant during normal exercise.
- 115 V, 0.73 A constant during normal exercise.

5.3 Supply cable characteristics

The supply cable complies to the most recent safety norms.

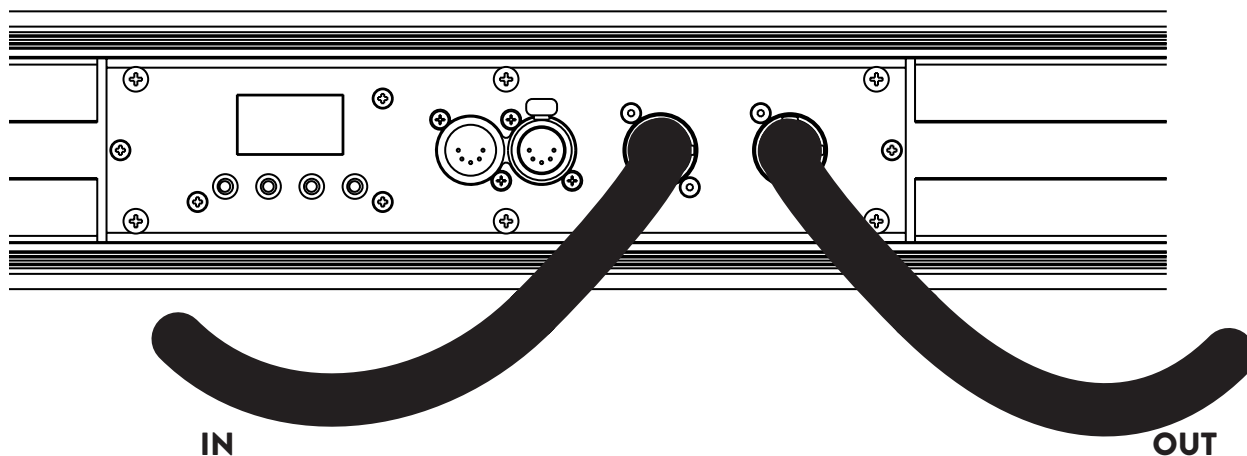

Warning!!

The use of a thermal/magnetic circuit breaker is recommended. Strict adherence to regulatory norms is strongly recommended.

StripLite Led RGBW should not be powered through a dimmer as this may damage the internal switching power supply.

Prior to connecting the device to mains power, ensure that the mains characteristics are within the recommended range for the use of **StripLite Led RGBW**.

All cabling and connections should be carried out by a suitably qualified personnel.

6. Control signal connections

6.1 Control signal connection by XLR5 plugs

The digital control signal is transmitted to the projector via two pole cable screened according to the International standards for the transmission of DMX 512 data. The connection must be serial, using connectors XLR5 male and female located on the back of **StripLite Led RGBW** labeled DMX512 IN e OUT (see diagram). Connectors equipped on **StripLite Led RGBW** are IP rated, which ensures protection against water and dust. In order to keep this rating they must be connected exclusively to other IP rated connectors.

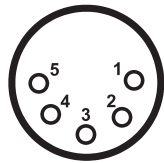

- Pin 1 = Ground (GND)**
- Pin 2 = Data -**
- Pin 3 = Data +**
- Pin 4 = Not connected**
- Pin 5 = Not connected**

Warning!

Make sure that screening and conductors are not in contact one another or with the metal housing of the connector.

Pin#1 and housing must never be connected to the power supply unit.

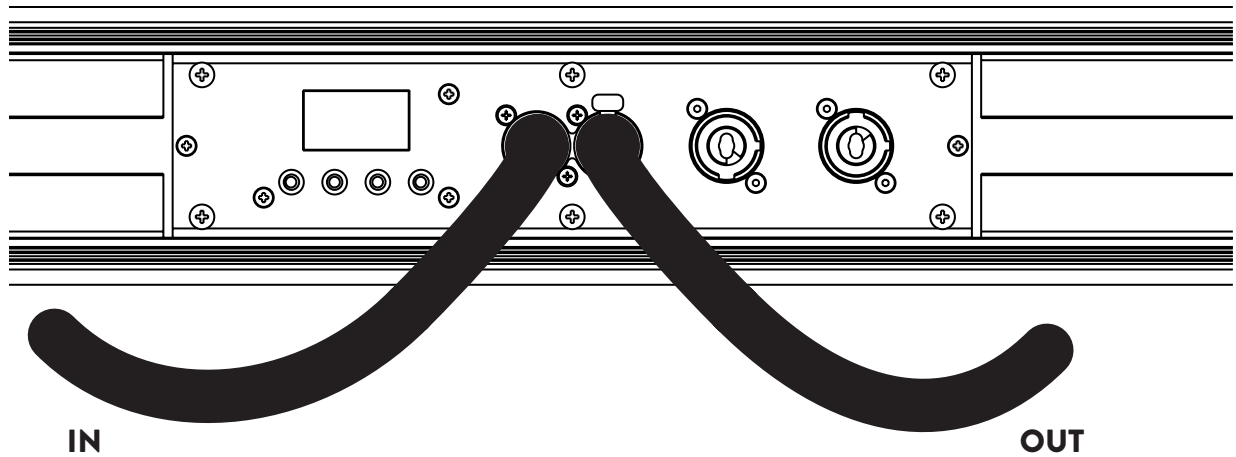

7. Turning on the projector

After having followed the preceding steps described, proceed with the power supply and turn on the projector connecting it to the mains power.

The software version installed on the internal microprocessors will be shown on the display, suddenly it will show the current DMX addressing. If the address blinks, it means that the DMX signal has not been received. Check the connection cable and the mixer functioning.

7.1 DMX address of the unit

Each projector can use 14, 8, 4, 1 or 7 address channels for its complete operation and is controlled by a DMX 512 signal.

DMX addressing

When powered up initially, each projector will show A001, which indicates DMX address 001; for example, when set at 14 channels a projector thus addressed will respond to commands of channel 1 to 14 from your DMX 512 controller. A second unit must be addressed as A015, a third one as A029 and so on. The operation must be carried out on every **StripLite Led RGBW** which has an address different from A001.

Altering the DMX address:

1. Press the + or – button until the display shows the required DMX address. The digits on the display will blink to indicate that the variation has not been registered.
2. Press the enter key to confirm your selection. The digits on the display panel will cease to blink and the projector will now respond to the new address.

Note: by holding the + or – button down the scrolling will be faster; thus allowing a faster selection

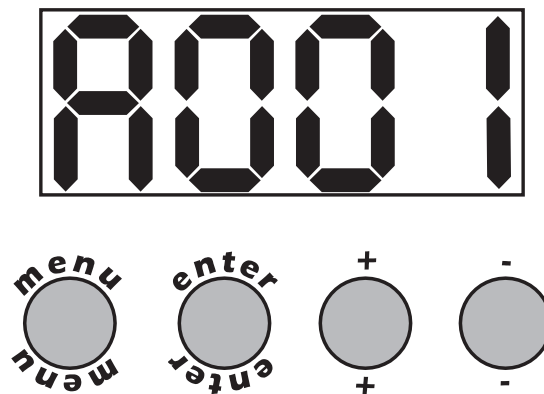

Warning!!

If you alter the DMX address with no DMX signal connected, the digits on the display panel will continue to flash even after you have pressed ENTER button to confirm the address.

8. DMX charts

8.1 DMX Chart 14, 8, 4, 1 channels

channel				function	type of control	effect	decimal	percentage
1	1	1	1	master dimmer	proportional	adjust luminous output intensity from 0 to 100%	0 - 255	0% - 100%
2	2	2	-	red	proportional	proportional control of the color percentage from 0 to 100%	0 - 255	0% - 100%
3	3	3	-	green	proportional	proportional control of the color percentage from 0 to 100%	0 - 255	0% - 100%
4	4	4	-	blue	proportional	proportional control of the color percentage from 0 to 100%	0 - 255	0% - 100%
5	5	5	-	white	proportional	proportional control of the color percentage from 0 to 100%	0 - 255	0% - 100%
6	6	-	-	strobe effect	step	no effect	0 - 9	0% - 4%
					proportional	variable speed strobing effect, from slow to fast	10 - 57	4% - 22%
					step	stop strobe	58 - 59	23% - 23%
					proportional	sequenced pulsed strobe, slow closing, fast operating (variable speed pulsing, from slow to fast)	60 - 108	24% - 42%
					step	stop strobe	109 - 110	43% - 43%
					proportional	sequenced pulsed strobe, fast closing, slow operating (variable speed pulsing, from slow to fast)	111 - 159	44% - 62%
					step	stop strobe	160 - 161	63% - 63%
					proportional	random strobe effect with variable speed from slow to fast and synchronized colors	162 - 207	64% - 81%
					step	stop strobe	208 - 209	82% - 82%
					proportional	random strobe effect with variable speed from slow to fast and non-synchronized colors	210 - 255	82% - 100%
7	7	-	-	dimmer fine	proportional	fine dimmer control 16 bit	0 - 255	0% - 100%

8	8	-	-	special function	step	park	0	-	9	0%	-	4%
						no effect	10	-	71	4%	-	28%
						600 Hz	72	-	84	28%	-	33%
						no effect	85	-	133	47%	-	52%
					step	LCD display off	134	-	185	53%	-	73%
						LCD display on	186	-	199	73%	-	78%
						LED control frequency tuning 1000 Hz	200	-	205	78%	-	80%
						LED control frequency tuning 3000 Hz	206	-	211	81%	-	83%
						LED control frequency tuning 6000 Hz	212	-	217	83%	-	85%
						LED control frequency tuning 8000 Hz	218	-	223	85%	-	87%
						LED control frequency tuning 10000 Hz	224	-	229	88%	-	90%
						LED control frequency tuning 12000 Hz	230	-	235	90%	-	92%
						LED control frequency tuning 14000 Hz	236	-	241	93%	-	95%
						LED control frequency tuning 16000 Hz	242	-	247	95%	-	97%
						LED control frequency tuning 19000 Hz	248	-	255	97%	-	100%
9	-	-	-	red tone	step	no effect	0	-	255	0%	-	4%
						RED Preset 1	10	-	71	4%	-	28%
						RED Preset 2	72	-	133	28%	-	52%
						RED Preset 3	134	-	195	53%	-	76%
						RED Preset 4	196	-	255	77%	-	100%
10	-	-	-	green tone	step	no effect	0	-	255	0%	-	4%
						GREEN Preset 1	10	-	71	4%	-	28%
						GREEN Preset 2	72	-	133	28%	-	52%
						GREEN Preset 3	134	-	195	53%	-	76%
						GREEN Preset 4	196	-	255	77%	-	100%
11	-	-	-	blue tone	step	no effect	0	-	255	0%	-	4%
						BLUE Preset 1	10	-	71	4%	-	28%
						BLUE Preset 2	72	-	133	28%	-	52%
						BLUE Preset 3	134	-	195	53%	-	76%
						BLUE Preset 4	196	-	255	77%	-	100%

12	-	-	-	white tone	step	no effect	0	-	9	0%	-	4%
						White 2700 K	10	-	15	4%	-	6%
					proportional	proportional value from 2700 K to 3200 K	16	-	30	6%	-	12%
					step	White 3200 K	31	-	45	12%	-	18%
					proportional	proportional value from 3200 K to 4000 K	46	-	60	18%	-	24%
					step	White 4000 K	61	-	75	24%	-	29%
					proportional	proportional value from 4000 K to 5000 K	76	-	90	30%	-	35%
					step	White 5000 K	91	-	105	36%	-	41%
					proportional	proportional value from 5000 K to 5600 K	106	-	120	42%	-	47%
					step	White 5600 K	121	-	135	47%	-	53%
					proportional	proportional value from 5600 K to 7000 K	136	-	150	53%	-	59%
					step	White 7000 K	151	-	165	59%	-	65%
					proportional	proportional value from 7000 K to 8000 K	166	-	180	65%	-	71%
					step	White 8000 K	181	-	195	71%	-	76%
					proportional	proportional value from 8000 K to 9000 K	196	-	210	77%	-	82%
					step	White 9000 K	211	-	225	83%	-	88%
proportional	proportional value from 9000 K to 10000 K	226	-	240	89%	-	94%					
step	White 10000K	241	-	255	95%	-	100%					
13	-	-	-	green saturation	step	no effect	0			0%		
					proportional	exalts the green color in the mixing and diminishes the presence of magenta	1	-	127	0%	-	50%
					step	no effect	128			50%		
					proportional	diminishes the presence of green in the mixing and exalts the magenta color	129	-	246	51%	-	99%
					step	no effect	255			100%		
14	-	-	-	saturation	proportional	the white tone fades to the tone built with RGBW channels	0	-	255	0%	-	100%

NOTE 1: color macros of channels 9 - 10 - 11 - 12 can also be obtained though the mixing of channels 2 - 3 - 4 - 5.

NOTE 2: the one channel function mode can be selected though the DMX function menu. The color temperature is selectable by display

NOTE 3: the rest position of the green saturation DMX channel is 128. Diminishing the DMX value augment the presence of the green color. Increasing the DMX value augments the presence of magenta

NOTE 4: increasing the value of the Saturation DMX channel the white light will fade to the color selected with the RGBW DMX channel.

8.2 DMX Chart 7 channels

channel	function	type of control	effect	decimal	percentage
1	master dimmer	proportional	adjust luminous output intensity from 0% to 100%	0 - 255	0% - 100%
2	color temperature	step	White 2700 K	0 - 15	0% - 6%
		proportional	proportional value from 2700 K to 3200 K	16 - 30	6% - 12%
		step	White 3200 K	31 - 45	12% - 18%
		proportional	proportional value from 3200 K to 4000 K	46 - 60	18% - 24%
		step	White 4000 K	61 - 75	24% - 29%
		proportional	proportional value from 4000 K to 5000 K	76 - 90	30% - 35%
		step	White 5000 K	91 - 105	36% - 41%
		proportional	proportional value from 5000 K to 5600 K	106 - 120	42% - 47%
		step	White 5600 K	121 - 135	47% - 53%
		proportional	proportional value from 5600 K to 7000 K	136 - 150	53% - 59%
		step	White 7000 K	151 - 165	59% - 65%
		proportional	proportional value from 7000 K to 8000 K	166 - 180	65% - 71%
		step	White 8000 K	181 - 195	71% - 76%
		proportional	proportional value from 8000 K to 9000 K	196 - 210	77% - 82%
		step	White 9000 K	211 - 225	83% - 88%
proportional	proportional value from 9000 K to 10000 K	226 - 240	89% - 94%		
step	White 10000K	241 - 255	95% - 100%		
3	green saturation	step	no effect	0	0%
		proportional	exalts the green color in the mixing and diminishes the presence of magenta	1 - 127	0% - 50%
		step	no effect	128	50%
		proportional	diminishes the presence of green in the mixing and exalts the magenta color	129 - 246	51% - 99%
		step	no effect	255	100%
4	saturation	proportional	fine dimmer control 16 bit	0 - 255	0% - 100%
5	hue	proportional	reproduces the sequence arbitrary color cross-fades around the color space	0 - 255	0% - 100%
6	dimmer fine	proportional	fine dimmer control 16 bit	0 - 255	0% - 100%
7	special function	step	park	0 - 9	0% - 4%
			no effect	10 - 71	4% - 28%
			600 Hz	72 - 84	28% - 33%
			no effect	85 - 133	33% - 52%
			LCD display off	134 - 185	53% - 73%
			LCD display on	186 - 199	73% - 78%
			LED control frequency tuning 1000 Hz	200 - 205	78% - 80%
			LED control frequency tuning 3000 Hz	206 - 211	81% - 83%
			LED control frequency tuning 6000 Hz	212 - 217	83% - 85%
			LED control frequency tuning 8000 Hz	218 - 223	85% - 87%
			LED control frequency tuning 10000 Hz	224 - 229	88% - 90%
			LED control frequency tuning 12000 Hz	230 - 235	90% - 92%
			LED control frequency tuning 14000 Hz	236 - 241	93% - 95%
			LED control frequency tuning 16000 Hz	242 - 247	95% - 97%
LED control frequency tuning 19000 Hz	248 - 255	97% - 100%			

NOTE 1: the rest position of the Green saturation DMX channel is 128. Diminishing the DMX value augments the presence of the green color. Increasing the DMX value augments the presence of magenta.

NOTE 2: increasing the value of the Saturation DMX channel the white light will fade to the color selected with the RGBW DMX channel.

9. Display panel functions

9.1 Quick guide to menu

To access the menu's functions, just press the MENU button. Then press + or – buttons to scroll the pages and press the ENTER button to access to any other function.

By suitably using all the functions of **StripLite Led RGBW**, which can be activated through its display panel, it is possible to change some of the parameters and to add some functions.

Changing the preset settings made by **Coemar** can vary the functions of the projector so that it will respond differently to the controller; therefore carefully read about the functions described here before carrying out any possible selection.

9.2 Rapid count

Through the display panel of **StripLite Led RGBW** it is possible to quickly change the various numbers displayed for the different functions in the following 3 manners:

1. Pressing the + or – buttons will cause the count to be quicker.
2. Pressing first + and then – and then holding them down simultaneously will cause the numbers to jump to the highest value.
3. Pressing first – and then + and then holding them down simultaneously will cause the number to jump to the lowest value.

9.3 Main functions menu

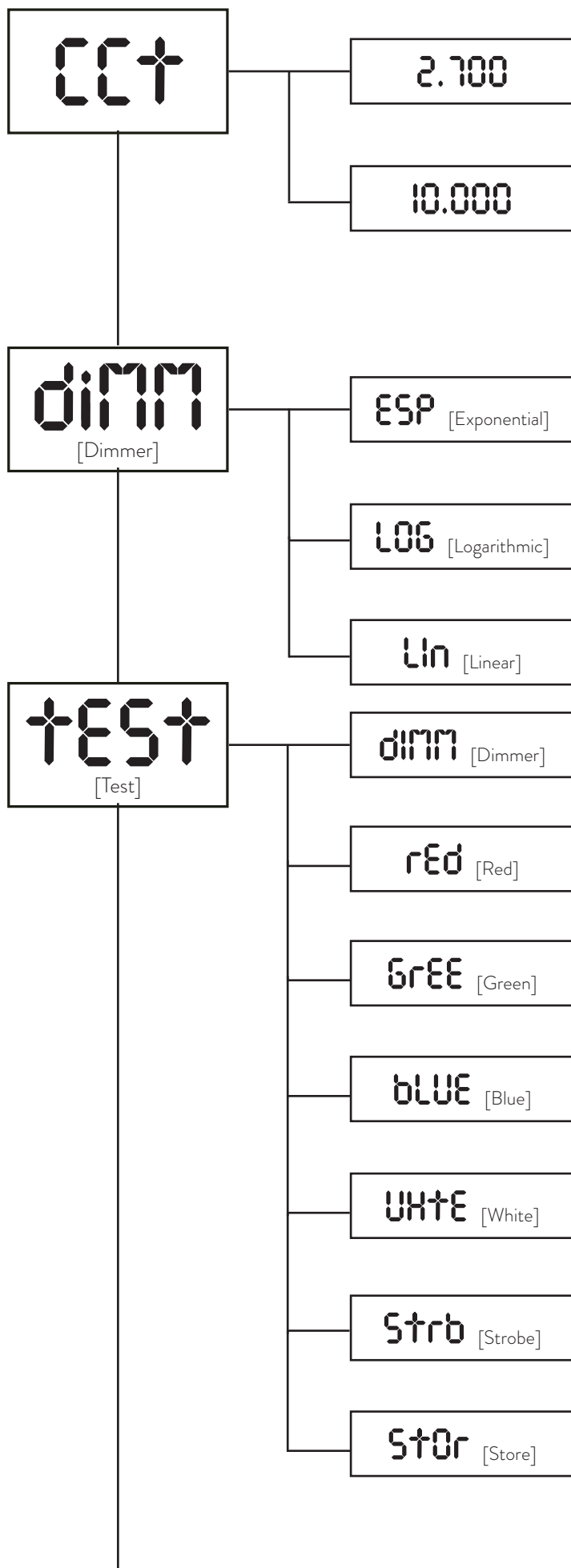

CCT:

It allows to vary the channel of white on several color temperatures from 2.700 K to 10.000 K, without DMX signal;

Dimmer:

It allows to choose the type of dimmer curves between exponential, logarithmic and linear (exponential as default)

Test:

Allows to manually set the DMX channels controlled by a DMX console:

- **Dimmer:** sets the luminous intensity;
- **Strobe:** manually sets the strobe DMX channel;
- **Store:** stores the modifications that will be set at the next times the fixture will be turned on.

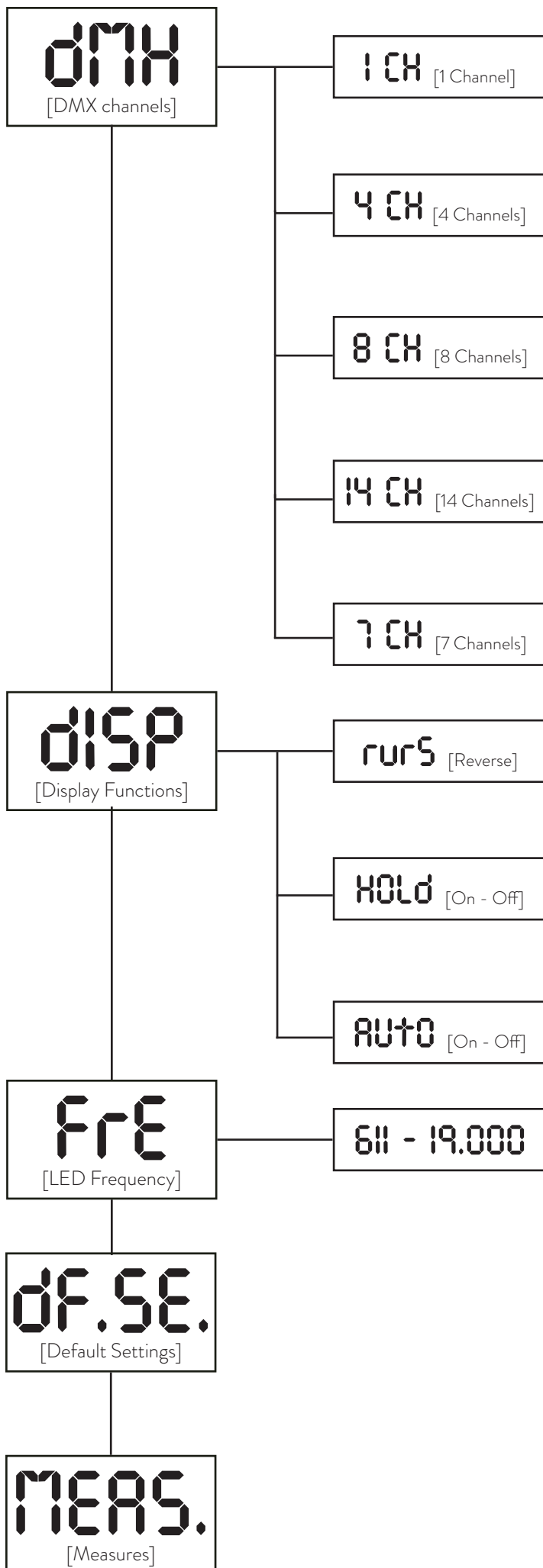

DMX channels:

- **1 CH:** it allows to change the white color temperature;
- **4 CH:** it allows to let the projector to work only with RGBW channels without dimmer;
- **8 CH:** it adds the master dimmer and the possibility to control the strobe frequency, fine dimming and special function channel;
- **14 CH:** it adds RGB color macros and white temperature channels with green presence and saturation control;
- **7 CH:** the extended functioning at 7 channels dmx with selection of the color temperature, saturation, plus/minus green saturation and the hue channel that reproduce the sequence arbitrary color cross-fades around the color space.

Display Functions:

- **Reverse:** it allows to turn 180° the reading of the display;
- **Hold:** locks the keys. Press any key for 5" to unlock;
- **Auto:** it allows to turn off the display after 6 seconds.

LED Frequency:

It allows to set the flickering frequency from 611 to 19.0000 Hz besides the default value. (DMX signals goes ahead this setting).

Default Settings:

Allows to restore the factory default of the fixture, with exception of DMX address and LED alignment.

Measures:

Allows to read all the parameters: LED and board temperatures, DMX ratio, DMX, alarms, channels value and software version.

9.4 Measure (MEAS)

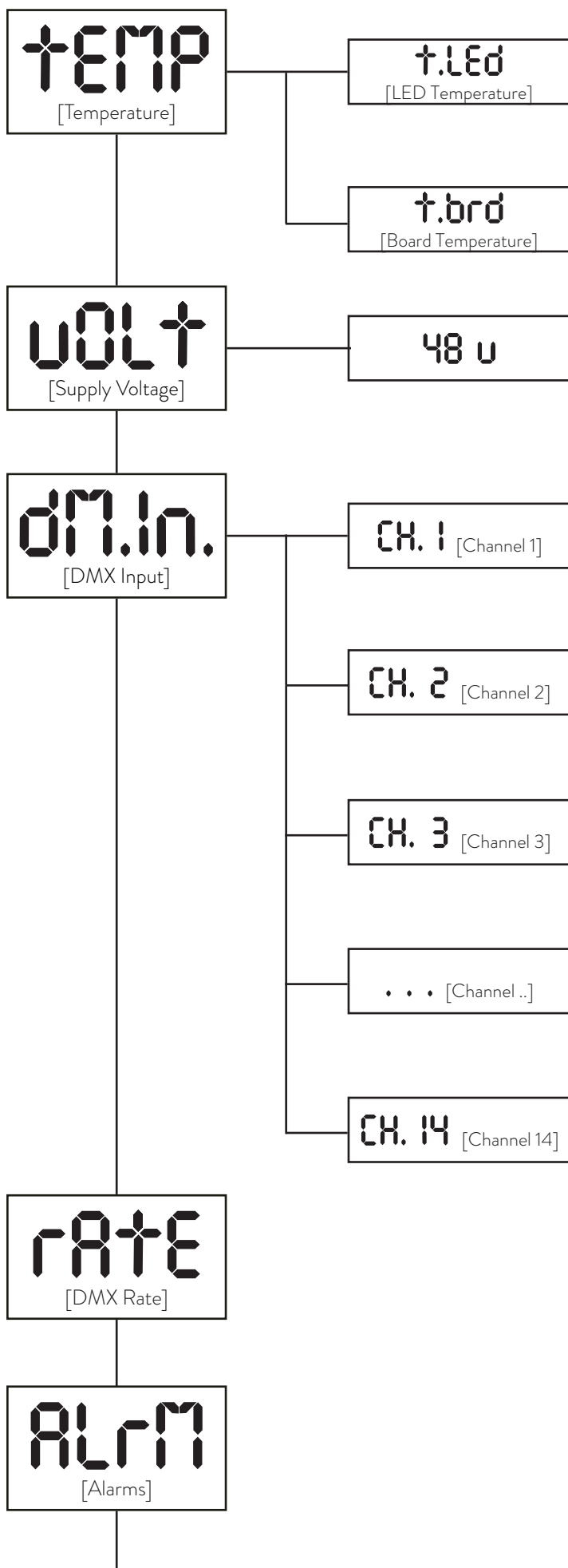

Temperature:

Shows the current temperature values:

- **LED:** shows the LED module temperature;
- **Board:** shows the electronic board temperature.

Volt:

Shows the power supply voltage.

DMX Input:

Shows the value of the DMX channels received by the fixture on every channel that the fixture occupies on the line.

Rate:

Shows the refresh rate of the DMX signal sent by the console.

Alarm:

This menu eventually shows the alarm statuses if there is any.

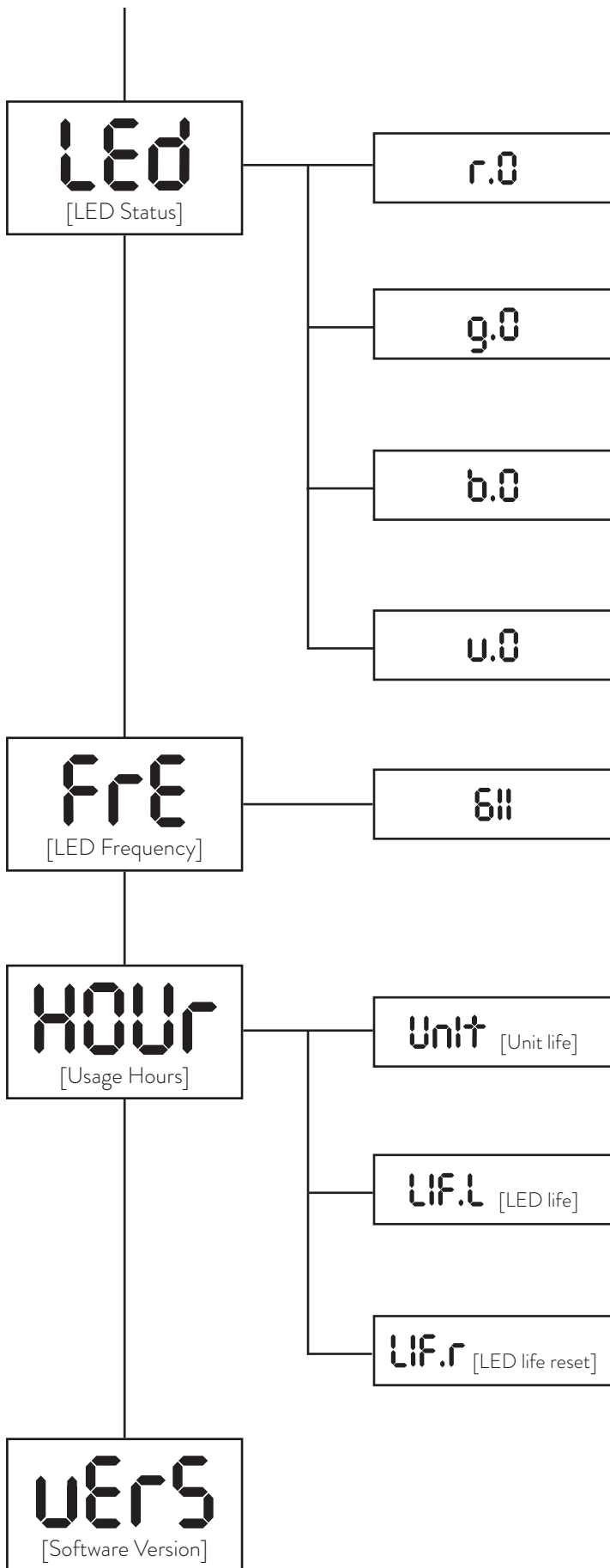

LED:

Shows the percentage value of the LED status.

Led frequency:

Shows the operating frequency of the LED (611 Hz as default).

Usage hours:

Shows the hour counter of the fixture:

- **Unit:** shows the overall hours of life of the fixture;
- **LED life:** shows the overall LED module life;
- **LED life reset:** shows the overall LED module life currently installed.

Note: this items can be reset in case of LED module replacement;

Software version:

Shows the software version currently installed in the fixture.

9.5 Electronic alignment of the leds

The display panel of **StripLite Led RGBW** allows the electronic alignment of the LEDs, this procedure is performed by **Coemar** at the time of testing, this procedure may be useful for special effects or in case of replacement of internal components (PCBs, LEDs, etc...).

Altering the settings made by **Coemar** may radically alter the operation of the projector's functions. Carefully read the following prior to attempting any changes.

Warning!!

This chapter should be considered for the exclusive use of technicians and qualified personnel.

Warning!!

This menu can only be accessed in the **DF.SE** [Default Settings] menu by pressing at the same time **ENTER** and **MENU** buttons.

This menu shall be accessed only by authorized technicians.

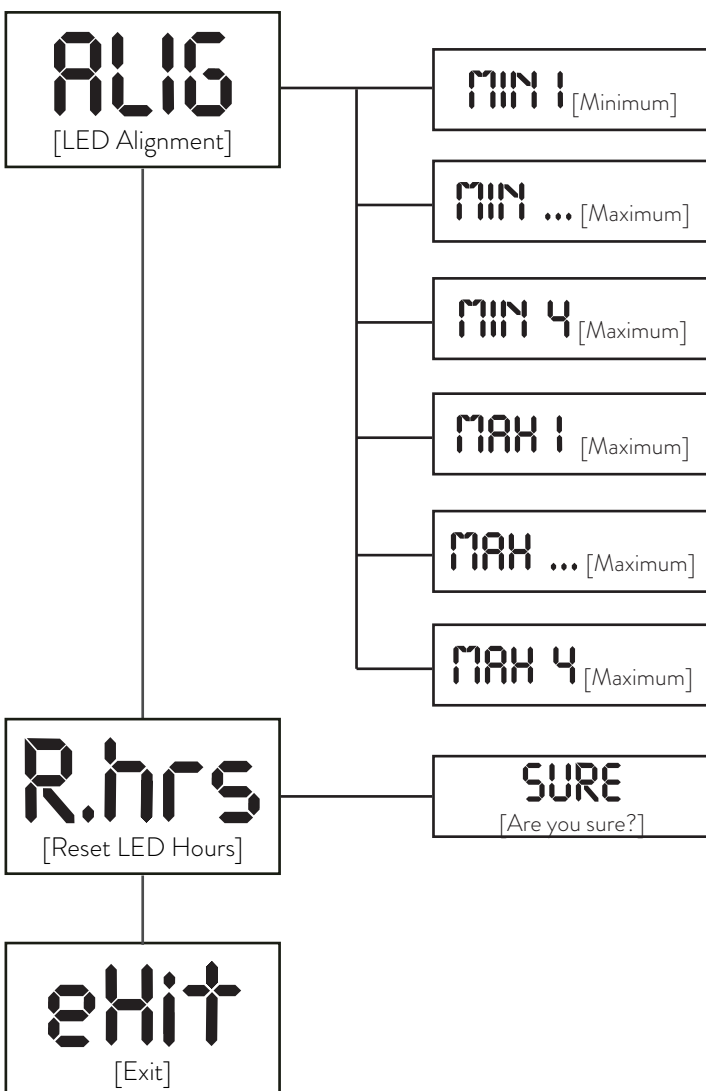

LED alignment:

This item allows to align the minimum and the maximum level of intensity of the LEDs:

- **Minimum:** raise or lowers the minimum intensity to level the dimming between the fixtures;
- **Maximum:** aligns the maximum output level between each fixture;
- **Exit:** exits the menu and stores the changes;

Reset hours:

Allows to erase the hours of operation of the LED module in case of replacement;

Exit:

Exits the menu and stores the new alignment parameters.

9.6 Special functions of the fixture

Storing the DMX signal

If you want to use the fixture without an active DMX console it is possible to store the DMX settings in two ways:

- Through the **TEST** menu;
- Disconnecting the DMX signal when the fixture is on. When the signal is disconnected the fixture stores the signal;

9.7 Error messages

If a malfunction occurs, **StripLite Led RGBW** has a self-diagnostic system that will show the error message on the display. The following table will explain in detail the most common errors. If, despite of suggested intervention, the problem persists, call the **Coemar** Service Center.

Codice errore	Descrizione
nO.AL. [No Alarm]	No Alarm The projector self-diagnostic routine didn't find any issue.
DTER [Data Error]	Data error Initial data loading has failed the projector loaded the default data settings: restart the fixture again, and if the error persists contact the Coemar assistance center.
ADER [Address Error]	Address error The projector does not receive all channels of DMX needs to function properly. Check the DMX address indicated on the display and the number of channels generated by the mixer control. We recall in this connection that some controllers do not generate all the 512 channels.
LED [LED Error]	LED error Auto diagnostic routine found that the LED module may be damaged, contact Coemar assistance for the module replacement. IMPORTANT: To ensure the sensor is giving correct readings, set the LED to the maximum light output level.

10. Accessories and spare parts

All the components of **StripLite Led RGBW** are available as spare parts from your **Coemar** dealer or Service. Accurate description of the fixture, model number and type will assist us in providing for your requirements in an efficient and effective manner.

11. Maintenance

11.1 Firmware update

The firmware of **StripLite Led RGBW** can be updated through the RDM protocol (ANSI E1.20). Contact **Coemar** assistance to receive the software and the device updater.

11.2 Periodic cleaning

Lenses

Even a fine layer of dust can reduce the luminous output and alter the compactness of the beam. Regularly clean all filters and lenses using a soft cotton cloth, dampened with a specialist lens cleaning solution.

Cleaning of the unit

Use a soft brush or a common vacuum cleaner or a source of compressed air for removing dust. For the cleaning of the housing use a soft cloth and a non-aggressive cleaner. Check that the internal heat exchanger must be perfectly clean.

11.3 Periodic controls

Mechanical components

Check the correct working of the mechanical parts and, if needed, replace them. Make sure the projector is not mechanically damaged. If necessary, replace the worn parts.

Electrical components

Check all electrical connections, in particular for correct grounding and correct attachment of all extractable connectors. Press the connectors if necessary and reposition as before.

11.4 Fuses

StripLite Led RGBW has an automatic fuse that in most cases does not need to be replaced.

12. F.A.Q. and answers

The following list shows common issues that may be simply solved. If issues persist, the unit must be repaired by qualified personnel or just contact your **Coemar** service near you.

Question	Possible solution
StripLite Led RGBW does not emit light	Projector not powered on: <ul style="list-style-type: none">• Make sure the power cord is plugged in or test the input voltage; Wrong DMX address: <ul style="list-style-type: none">• Check the DMX Address setting and the output signal of the controller;
StripLite Led RGBW does not answer to DMX signal	DMX signal may not reach StripLite Led RGBW: <ul style="list-style-type: none">• Inspect the cable connection, correct poor connections or inefficient repair or replace damaged cables;• Check DMX address of the unit;

User notes

A series of horizontal dotted lines for writing notes.



Information on disposal of the equipment

The equipment at the end of its useful life must be disposed of at an appropriate recycling center for waste electrical and electronic equipment. The treatment and disposal of environmentally friendly, helps prevent potential negative environmental and health and promote the reuse and / or recycling of materials making up the equipment. Illegal disposal by the user includes the application of administrative sanctions provided by law.



Coemar Lighting s.r.l.

Via Carpenedolo 90
46043 Castiglione delle Stiviere, Mantova, Italia
tel. +39 0376/1514412 - fax +39 0376/1514380
info@coemar.com

Coemar reserves the right to change specifications without prior notice