



PinSpot T/D

Product code: F033E100A (Tungsten) | F033F100A (Daylight)

KEY FEATURES

- Light source: LED module Tungsten or Daylight
- Concentrated beam angle: 4°
- Flicker-free operation
- No maintenance required
- Thick aluminium enclosure to guaranteed body resistance in the long term
- Lightweight and compact size



SPECIFICATIONS

- Fixed white CCT: 3.200 K or 5.600 K
- Flicker-free operation
- Beam angle: 4°
- Thick aluminium body
- Orientable yoke
- IP rating: 44

LIGHT SOURCE

- LED module Tungsten or Daylight
- Average LED lifetime: a minimum of 80% of the initial luminous flux will be maintained after approx. 50.000 hours of usage (50.000 LM80)

PHYSICAL SIZE

- Length: 102.5 mm (4.03 in)
- Width: 77 mm (3.03 in)
- Height: 48 mm (1.88 in)
- Height with bracket: 86.5 mm (3.40 in)
- Weight: 0.4 Kg (0.88 lbs)

CONTROL PROTOCOL AND PROGRAMMING

- Max 50 PinSpot for 1 RegoBox (10 per line)

ELECTRICAL SPECIFICATIONS AND CONNECTIONS

- DC power: 3 V
- T connection cable In/Out
- Max power consumption: 2 W
- Power consumption: 700 mA at 3 V

ACCESSORIES

- RegoBox 5CH DMX512
- Cable KIT start/end

DRAWING SIZE

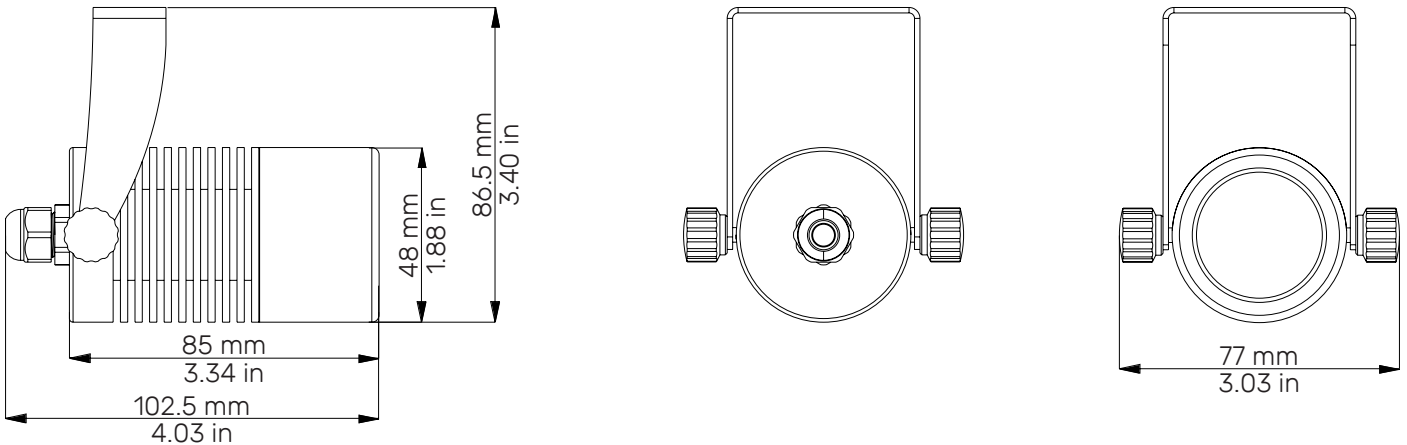

HOW TO CONNECT PINSPOT

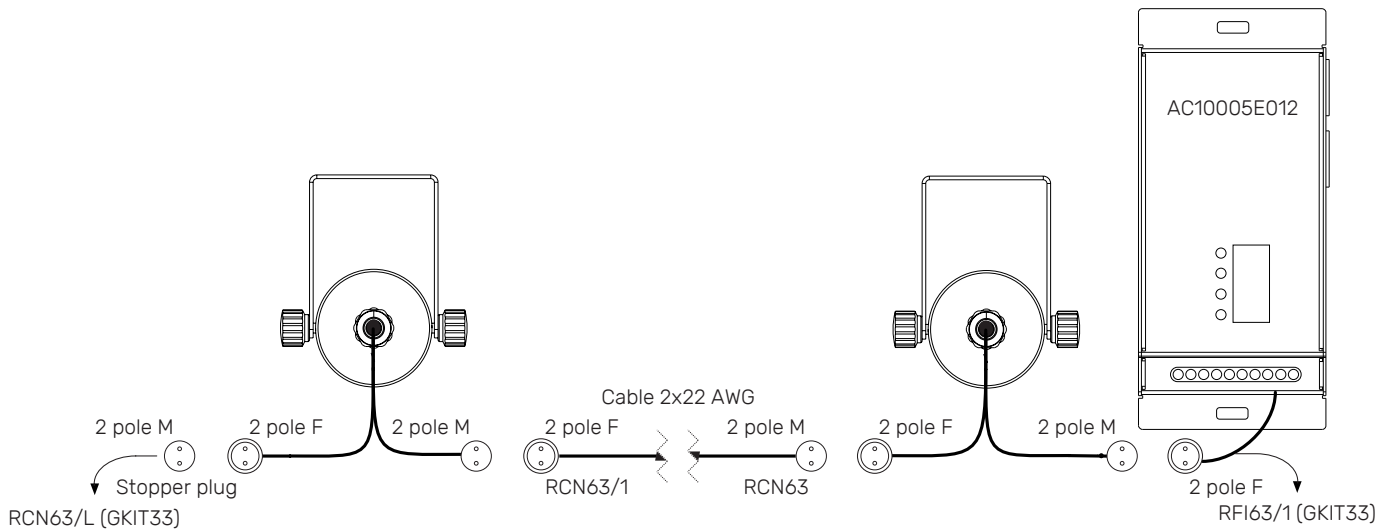

PHOTOMETRIC DATA

The PinSpot Photometric Data may be downloaded from www.coemar.com.

ACCESSORIES

Code	Description
AC10005E012	RegoBox 5CH DMX512
GKIT33	Cable KIT start/end