



ReLite Led T

Product code: F032C040A (CRI 90) | F032A040A (CRI 97)

KEY FEATURES

- LED retrofit lamp
- Revitalize your 1K and 2K Fresnel fixtures thanks to ReLite: your true retrofit
- Excellent white light quality with CRI 90 or CRI 97
- Flicker-free ideal for TV/Broadcast installations
- Linear dimming from 1% to 100% from traditional TRIAC AC or IGBT dimmers
- No color-shift with dimming
- Huge power savings (reduce your power consumption by over 90%) with almost no heat generated



SPECIFICATIONS

- Fixed white CCT: 3.200 K
- Linear dimming from 1% to 100%: the stability of the fixture is guaranteed starting from 30/35 % of the dimmer channel (depending on the installation conditions)
- Flicker-free operation (dimming with constant current)
- Audio noise: dbA 14
- IP rating: 20
- Thermal protection
- CE approved
- Instantly upgrade an existing Arri, ADB or DeSisti (and more)

LIGHT SOURCE

- Tungsten COB LED (CRI 90 or CRI 97)
- Average LED lifetime: a minimum of 80% of the initial luminous flux will be maintained after approx. 50.000 hours of usage (50.000 LM80)

PHYSICAL SIZE

- Length: 91 mm (3.58 in)
- Width: 107 mm (4.21 in)
- Height: 110 mm (4.33 in)
- Height with connectors: 134 mm (5.28 in)
- Weight: 0.8 Kg (1.7 lbs)

ELECTRICAL SPECIFICATIONS AND CONNECTIONS

- Power supply: 90-240 V, auto-sensing, 50/60 Hz
- Max power consumption: 160 W
- Power consumption: 0.7 A at 230 V 1.48 A at 110 V, $\cos\phi$ 0.98
- Pin Connectors: G22

ACCESSORIES

- G22 adaptor (2000 W)
- G38 adaptor

DRAWING SIZE

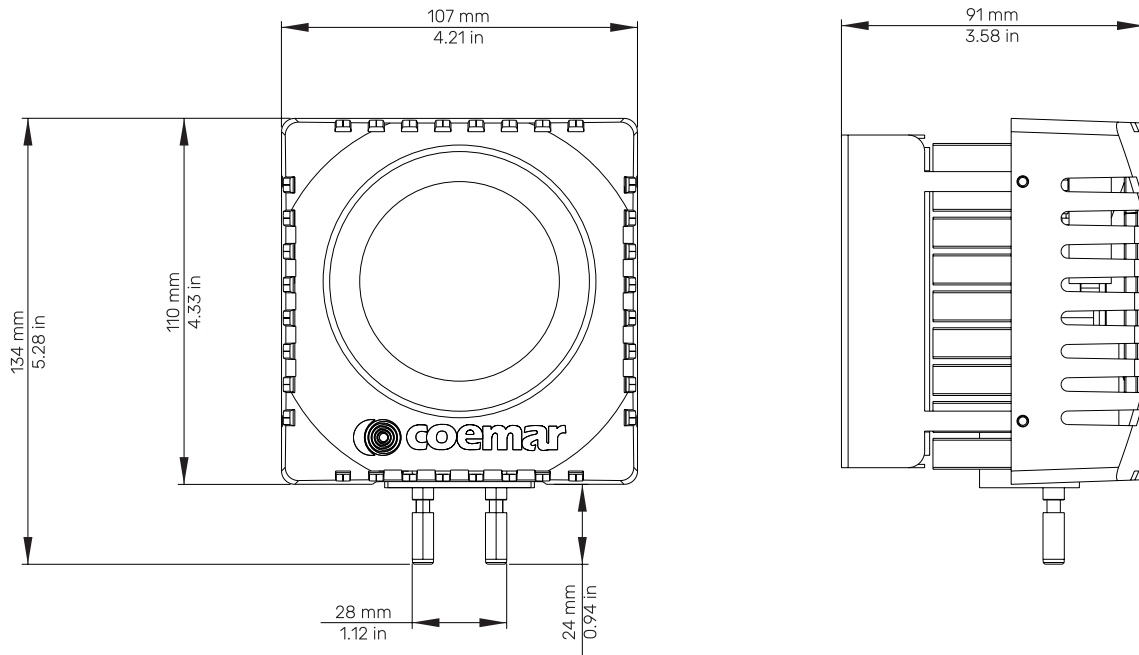

PHOTOMETRIC DATA

The ReLite Led Photometric Data may be downloaded from www.coemar.com.