



# ReLite Led

Product code: T CRI 90 - F032C040A / T CRI 97 - F032A040A  
D CRI 90 - F032D040A / D CRI 97 - F032B040A

## KEY FEATURES

- Revitalize your 1k and 2k Fresnel fixtures thanks to ReLite: your true retrofit LED relamping option
- Flicker-free ideal for TV/Broadcast installations
- Excellent white light quality with CRI 90 or CRI 97
- Smooth dimming from 30/35 to 100% from traditional triac AC or igbt dimmers
- No color-shift with dimming
- Huge power savings (reduce your power consumption by over 90%) with almost no heat generated
- No heat on your subject



## SPECIFICATIONS

- Fixed white CCT at 3200 K or 5600 K
- Full-range dimming on your existing AC Dimmers
- Flicker-free (dimming with constant current)
- Operating Ta (°C/F) range: -20 to 45°C (-4 to 113° F) thermal protection at 65°C/149°F
- Audio noise dbA: 14
- Instantly upgrade an existing Arri, ADB or De Sisti (and more)

## LIGHT SOURCE

- CRI 90 (160W) COB LED (Tungsten)  
CQS: 92, DUV: 0.0015, TLCI: 89.7, GAI: 54
- CRI 97 (115W) COB LED (Tungsten)  
CQS: 98, DUV: 0.0008, TLCI: 97.4, GAI: 53.7
- CRI 90 (160W) COB LED (Daylight)  
CQS: 95, DUV: -0.0019, TLCI: 98.4, GAI: 96.8
- CRI 97 (115W) COB LED (Daylight)  
CQS: 90, DUV: 0.0015, TLCI: 91.1, GAI: 89.8
- LEDs life: 20.000 hours at 70% lumen intensity maintenance

## PHYSICAL SIZE

- Depth: 91 mm (3.58 in)
- Width: 107 mm (4.21 in)
- Height: 110 mm (4.33 in)
- Height with connectors: 134 mm (5.28 in)
- Weight: 0.8 Kg (1.7 lbs)

## ELECTRICAL SPECIFICATIONS AND CONNECTIONS

- Power supply: 90 -240 Vac, 50-60 Hz
- Max power consumption: 0.5 A (CRI 97), 0.7 A (CRI 90) at 230V, Cosφ 0.98
- Pin Connectors: G22 - G38 adaptor

## ACCESSORIES

- G22 socket (2000 W)

## DRAWING SIZE

---

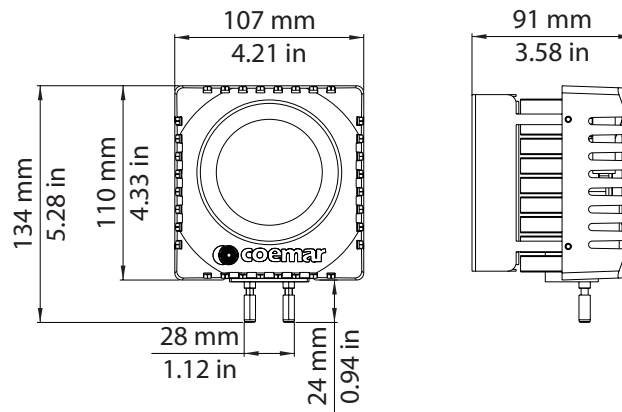

## PHOTOMETRIC DATA

---

The ReLite Led Photometric Data may be downloaded from [www.coemar.com](http://www.coemar.com).