



StageLite Led FX

Product code: F009L020F

KEY FEATURES

- Pixel control 32 ch
- A truly unique fixture which can be focused asymmetrically on a Cyc, used as a foot wash, up lighting, and an effects unit from the same mounting position.
- The vertical beam zoom from 11° to 34° can be also focused from +56° to -52° (Patent Pending)
- Asymmetric and symmetric beam in one single fixture (Patent Pending)
- Swing effect
- 75% to 82% energy saving compared to traditional technology at the same brightness
- Robust aluminum, long lasting light source in long lasting body
- No fan, no maintenance, no noise
- Flicker free

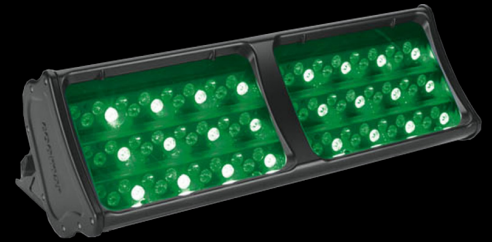

SPECIFICATIONS

- RGB+White color mixing
- Intensity of each ½ line of LEDs can be individually controlled
- 4 different control modes: global (compact), 2 zones (cell), 3 lines (lines), 6 ½ lines (frames)
- Proportional zoom 11° - 34° (vertical beam, ½ peak angle)
- The light beam is generated by three independent optical planes (Patent Pending) with 3 different kinds of customized (40x13° lenses mounted)
- Orientable beam from +56° to -52°; linear adjustment with digital positioning control: concentrate, symmetrical or asymmetrical
- Electronic dimmer
- Electronic strobe, synchronized, random, pulse effect
- Swing effects
- Flicker free, LEDs frequency controlled by DMX
- Orientable standing feet
- Quick camlock clamps, on a modular guide with adjustable position
- Weatherproof rating IP 20 or IP 65

LIGHT SOURCE

- 96 XP Cree LEDs, 24 Red, 24 Green, 24 Blue and 24 White (6000 Kelvin)
- LEDs life: 20.000 hours at 70% lumen intensity maintenance

PHYSICAL SIZE

- Length: 609 mm (24 in)
- Width: 211 mm (8.3 in)
- Height: 181 mm (7.1 in)
- Weight: 12 kg (26,4 lbs)

CONTROL PROTOCOL AND PROGRAMMING

- USITT DMX512/1990
- Dmx channels: 32/20/16/12
- Setting and addressing: LEDs display or remotely

ELECTRICAL SPECIFICATIONS AND CONNECTIONS

- AC power: 90-250 V, auto sensing, 50/60 Hz, 2m (6.6 ft) integral cable without power plug, with PowerCon connector (only IP 20 version)
- Power consumption: 1 A at 230 V, 2 A at 115 V
- DMX data in/out: 5 pin locking XLR

ACCESSORIES

- 2 ground-standing feet
- Quick camlock clamps
- PowerCon cable (2m)
- PowerCon cable In/Out cable (2m)

DRAWING SIZE

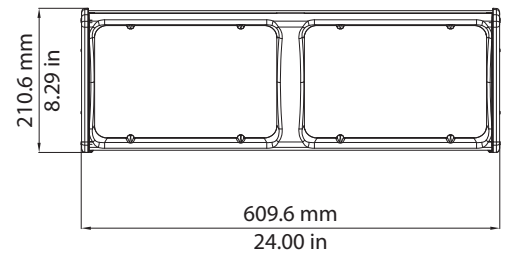
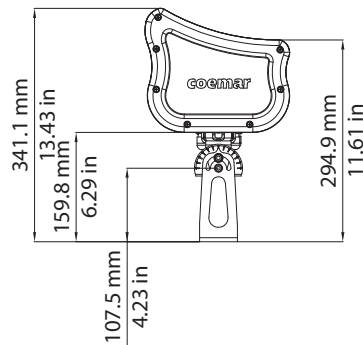
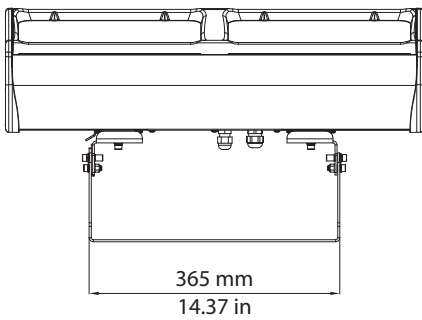

DMX CHARTS

32 channels (frames)		
	1	dimmer fine
frame 1	2	red
	3	green
	4	blue
	5	white
	6	red
frame 2	7	green
	8	blue
	9	white
	10	red
frame 3	11	green
	12	blue
	13	white
	14	red
frame 4	15	green
	16	blue
	17	white
	18	red
frame 5	19	green
	20	blue
	21	white
	22	red
frame 6	23	green
	24	blue
	25	white
	26	strobe effect
	27	led line 1
	28	led line 2
	29	led line 3
	30	automated function and fade speed
	31	effect movement
	32	motors reset and special functions

20 channels (lines)		
	1	dimmer fine
line 1	2	red
	3	green
	4	blue
	5	white
	6	red
line 2	7	green
	8	blue
	9	white
	10	red
line 3	11	green
	12	blue
	13	white
	26	strobe effect
	27	led line 1
	28	led line 2
	29	led line 3
	30	automated function and fade speed
	31	effect movement
	32	motors reset and special functions

16 channels (zones)		
	1	dimmer fine
zone 1	2	red
	3	green
	4	blue
	5	white
	6	red
zone 2	7	green
	8	blue
	9	white
	26	strobe effect
	27	led line 1
	28	led line 2
	29	led line 3
	30	automated function and fade speed
	31	effect movement
	32	motors reset and special functions

12 channels (global)		
	1	dimmer fine
global	2	red
	3	green
	4	blue
	5	white
	6	strobe effect
	7	led line 1
	8	led line 2
	9	led line 3
	10	automated function and fade speed
	11	effect movement
	12	motors reset and special functions

PHOTOMETRIC DATA

The StageLite Led Photometric Data may be downloaded from www.coemar.com.

ACCESSORIES

Code	Description
PC08052/1	2 ground-standing feet
PC08052/3	Quick calock clamps
PC08052/4	PowerCon cable (2m)
CV18	PowerCon cable In/Out (2m)