



# PinLite Led RGB

Product code: F010100B

## KEY FEATURES

- Electronic dimmer
- Electronic strobe
- Flicker-free operation
- Double yoke for easy ground standing or easy truss hanging
- Variable beam angles due to quickly interchangeable optics (12°, 30°, 13° x 40°, 50°, 110°)
- Conventional cooling, no fans, ideal for broadcast and theatre installation



## SPECIFICATIONS

- RGB color mixing
- Standard lens 12°
- Electronic dimmer
- Electronic strobe, synchronized, random, pulse effect
- Flicker-free operation
- Double yoke for easy ground standing or truss hanging
- IP rating: 20 or 65 (weatherproof)

## LIGHT SOURCE

- 12 LEDs Cree (4 Red, 4 Green, 4 Blue)
- Average LED lifetime: a minimum of 80% of the initial luminous flux will be maintained after approx. 50.000 hours of usage (50.000 LM80)

## PHYSICAL SIZE

- Length: 168.9 mm (6.65 in)
- Width: 140.9 mm (5.55 in)
- Height: 128.5 mm (5.06 in)
- Height with bracket: 205 mm (8.07 in)
- Weight: 1.8 Kg (4 lbs)

## CONTROL PROTOCOL AND PROGRAMMING

- USITT DMX512A
- DMX channels: 5
- Setting and addressing: binary dip switch or remotely
- 4 Internal automatic programs
- RDM (Remote Device Management)

## ELECTRICAL SPECIFICATIONS AND CONNECTIONS

- AC power: 90-250 V, auto-sensing, 50/60 Hz, 2 m (6.6 ft) integral cable without power plug
- Max power consumption: 25 W
- Power consumption: 0.18 A at 230 V, 0.36 A at 115 V -  $\cos\phi$  0.6
- DMX data in/out: 5 pin locking XLR

## ACCESSORIES

- 30° lens kit
- 50° lens kit
- 13° x 40° elliptical lens kit
- 110° flood reflector
- Support color frame holder
- Frame for internal frost filter
- Frame for external frost filter
- IP 65 rear panel

## DRAWING SIZE

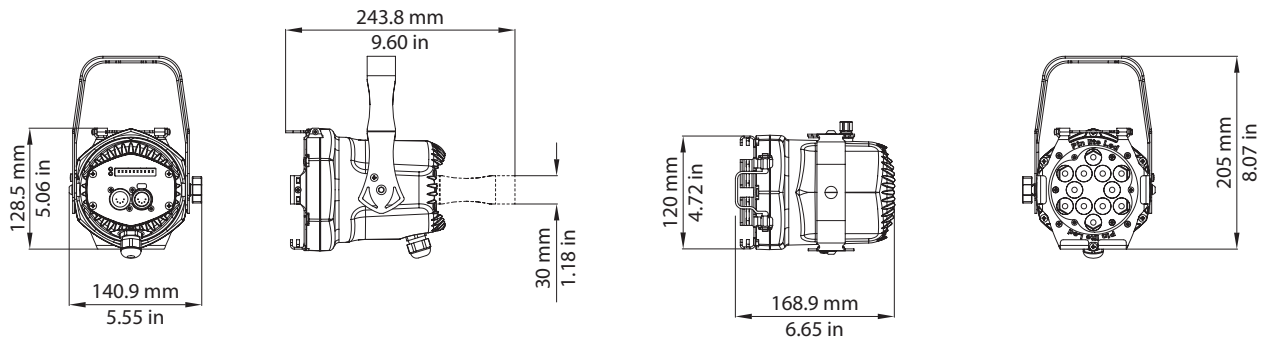

## DMX CHARTS

5 channels	
1	red
1 (A)	speed
Note 1: the second function 1 (A) is enabled when channel 5 is active	
2	green
2 (A)	speed
Note 2: the second function 2 (A) is enabled when channel 5 is active	
3	blue
4	strobe effect
5	automated function

## DIP-SWITCH CHARTS

dip-switch	DMX function	DR1 function
1	dmx channel 1	Id value 1
2	dmx channel 2	Id value 2
4	dmx channel 4	Id value 4
8	dmx channel 8	Id value 8
16	dmx channel 16	Id value 16
32	dmx channel 32	Id value 32
64	dmx channel 64	Id value 64
128	dmx channel 128	Id value 128
256	dmx channel 256	Id value 256
auto	off	off
test	off	off
light on	off	off
n.f.	off	off
n.f.	off	off
dr1	off	on
3ch	on	off
Note 1: the dip-switch AUTO-TEST-LIGHT ON-DR1 must be set correctly to avoid function conflicts.		
led	function	
green	power	
yellow	dmx state	

## PHOTOMETRIC DATA

---

The PinLite Led Photometric Data may be downloaded from [www.coemar.com](http://www.coemar.com).

## ACCESSORIES

---

Code	Description
BC10010A001	Support color frame holder black
BC10010A002	Support color frame holder silver
PC09186	30° lens kit
PC09186/3	50° lens kit
PC09186/2	40° x 13° lens kit
PC09187	110° flood reflector
PC09188	Frame for internal frost filter
PC09188/1	Frame for external frost filter
GPAN10	IP 65 rear panel black
GPAN10/1	IP 65 rear panel silver