

coemar

ProSpot L

**instruction
manual**

1st edition, december 2000

Index

| | |
|---|--------|
| 1. Packaging | Pag. 3 |
| 2. Transportation | .. 3 |
| 3. Important safety information | .. 4 |
| 4. Lamp: installation and replacement | .. 5 |
| 5. Operating voltage and frequency | .. 7 |
| 6. Mounting the unit | .. 8 |
| 7. Mains connection | .. 9 |
| 8. Signal connection | .. 10 |
| 9. Powering up | .. 12 |
| 10. DMX addressing | .. 13 |
| 11. Display panel functions | .. 14 |
| 11.1. Turning on the ProSpot LX without articulated movement | .. 15 |
| 11.2. Resetting the electronic lamp life counter | .. 16 |
| 11.3. test | .. 16 |
| 12. DMX 512 channel functions | .. 17 |
| 13. Aligning the lamp in the optical path | .. 21 |
| 14. Automatic repositioning features | .. 22 |
| 15. Gobo replacement | .. 22 |
| 16. Altering the operating voltage and frequency (Reserved for technical staff only) | .. 23 |
| 16.1 Selecting the voltage on the autotransformer | .. 23 |
| 16.2 Selecting the frequency on the power supply of the ProSpot LX | .. 24 |
| 17. Maintenance | .. 25 |
| 19. Electronic alignment of motors | .. 26 |
| 20. Error messages | .. 27 |
| 21. Spare parts | .. 27 |

Congratulations on having purchased a **coemar** product. You have assured yourself of a fixture of the highest quality, both in componentry and in the technology used. We renew our invitation to you to complete the service information on the previous page, to expedite any request for service information or spares (in case of problems encountered either during, or subsequent to, installation). This information will assist in providing prompt and accurate advice from your **coemar** service centre.

1. Packaging

Following the instructions and procedures outlined in this manual will ensure the maximum efficiency of this product for years to come.

Open the packaging and ensure that no part of the equipment has suffered damage in transit. In case of damage to the equipment, contact your carrier immediately by telephone or fax, following this with formal notification in writing.

packing list

Ensure the packaging contains:

- 1 **ProSpot LX**
- 1 **instruction manual**
- 1 **T 8A fuse**

2. Transportation

The **ProSpot LX** should be transported in its original packaging or in a coemar approved flight case.

We recommend the use of a suitable flight case, which will stop the articulated movement of the **ProSpot LX** during transportation.

3. Important safety information

Fire prevention:

1. **ProSpot LX** utilises a Philips MSD 250W/2. The use of any other lamp is not recommended and will null and void the fixture's warranty.
2. Never locate the fixture on any flammable surface.
3. The minimum distance from flammable materials: 0,5 m.
4. The minimum distance from the closest illuminable surface: 2 m.
5. Replace any blown or damaged fuses only with those of identical values. Refer to the schematic diagram if there is any doubt.
6. Connect the projector to main power via a thermal magnetic circuit breaker.

Prevention of electric shock:

1. High voltage is present in the internals of the unit. Isolate the projector from mains supply prior to performing any function, which involves touching the internals of the unit, including lamp replacement.
2. For mains connection, adhere strictly to the guidelines outlined in section 7 of this manual.
3. The level of technology inherent in the **ProSpot LX**, requires the use of specialised personnel for all service applications; refer all work to your authorised **coemar** service centre.
4. A good earth connection is essential for proper functioning of the projector. Never operate the unit without proper earth connection.
5. The fixture should never be located in an exposed position, or in areas of extreme humidity. A steady supply of circulating air is essential.

Protection against ultraviolet radiation:

1. Never turn on the lamp if any of the lenses, filters, or the housing is damaged, their respective functions will only operate efficiently if they are in perfect working order.
2. Never look directly into the lamp when it is operating.

Safety:

1. The projector should always be installed with bolts, clamps, and other fixings, which are suitably rated to support the weight of the unit.
2. Always use a secondary safety chain of a suitable rating to sustain the weight of the unit in case of the failure of the primary fixing point.
3. The external surfaces of the unit at various points may exceed 80°C. Never handle the unit until at least 10 minutes have elapsed since the lamp was turned off.
4. Always replace the lamp if any physical damage is evident.
5. Never install the fixture in an enclosed area lacking sufficient airflow; the ambient temperature should not exceed 45°C.
6. A hot lamp may explode. Always wait for at least 10 minutes to elapse after the unit has been turned off prior to attempting to replace the lamp.
Always wear suitable hand protection when handling lamps.

4. Lamp: Installation and replacement

ProSpot LX utilises a Philips MSD 250W/2 or equivalent.

The lamp is available from your authorised **coemar** sales agent:

| | |
|--------------------|-----------------|
| coemar cod. | 105214/1 |
| power | 250 w |
| luminous flux | 18.000 lm |
| colour temperature | 8.500° K |
| lamp base | GY 9,5 |
| approximate life | 2000 hours |

Attention

Disconnect mains prior to opening up the unit

The fixture's internal temperature can reach 150° C after 5 minutes with a maximum peak of 350° C; ensure that the lamp is cold prior to attempting removal. The fixture should be allowed to stand and cool for 10 minutes prior to its removal.

The lamps are part of the mercury vapour family of discharge lamps and must be handled with great care. The lamps operate at high pressure, and the slight risk of explosion exists if operated over their recommended lamp life.

We recommend, therefore, that the lamp be replaced within the manufacturer's specified lamp life.

installing the lamp

- 1) Using a Philips head screwdriver, remove the 4 screws **A** located at the front and rear of the projector, which affix the top cover **B**, as shown in the diagram below.



- 2) Remove the housing **B**.

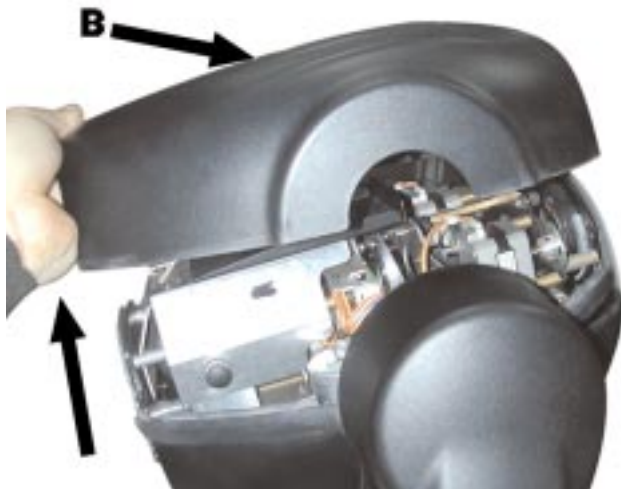

- 3) Remove the three thumbscrews **C**, which hold the lamp-cover in place, and remove the cover.



English

- 4) Locate the lampholder **D**

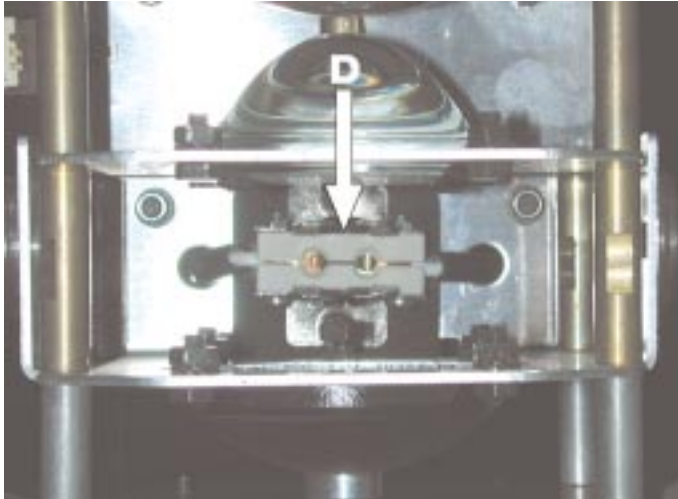

- 5) Insert the lamp. The lamp is manufactured from quartz glass and should be handled with care; always adhere to the instructions supplied in the lamp's packaging. Never touch the glass directly; use the tissue provided in the lamp's packaging. The GY 9,5 lampholder is asymmetrical in construction, with one lamp pin larger than the other is. **DO NOT USE UNDUE FORCE.** In case of difficulty, inspect for physical damage and then repeat the installation procedure.

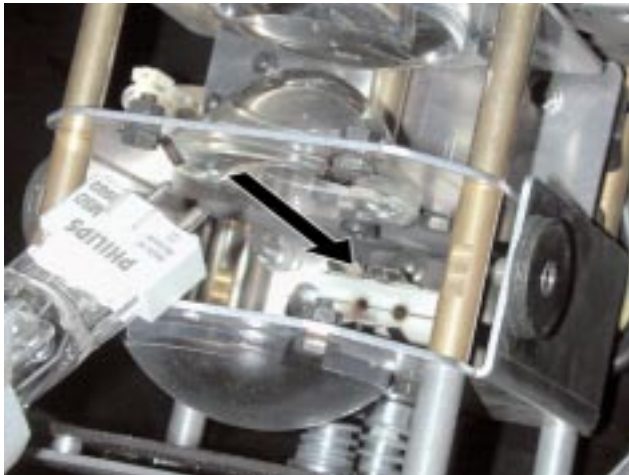

- 6) The optimal gap between the lamp and the parabolic reflector is around 2 to 3 mm. If this is not the case, rotate the two adjusting thumbscrews located at the rear of the projector as indicated in the section of this manual entitled **"Aligning the lamp in the optical path"**. **The lamp must under no circumstances come into contact with the reflector or other components of the optical system.**



- 7) Reposition the lamp cover and replace the three screws **C** previously removed. Replace the housing **B** and refasten the four screws **A** as per the original condition of the **ProSpot LX**. Prior to switching on the projector with the new lamp installed, reset the lamp life counter as described in section **11 "Display panel functions"**.

We recommend that replacement lamps be realigned in the optical path of the lamp so as to avoid any accidental overheating of the internal components of the fixture. This procedure is described in the section of this manual entitled **"Aligning the lamp in the optical path"**.

5. Operating voltage and frequency

The projector may operate at 100-115-208, 230 or 245V .at 50 or 60 Hz; **coemar** presets (barring specific requests), an operating voltage of 230V and a frequency of 50Hz. The operating voltage and frequency of the projector is noted on the base of the unit.

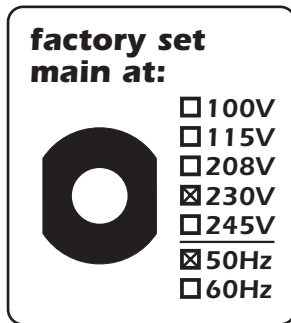

If this preset does not correspond with the conditions in your particular country of operation, follow the instructions in the appropriate section of this manual.

Incorrect frequency and voltage selection will detrimentally affect the operation of the projector.

6. Installing the unit

mounting

ProSpot LX can operate in any mounting position.

The structure from which the unit is hung should be of sufficient rating to hold the weight of the unit, as should any clamps used to hang the unit. The structure should also be sufficiently rigid so as to not move or shake whilst the **ProSpot LX** moves during its operation.

The two mounting holes Ø13 mm (**A**) on the base of the **ProSpot LX** allows the projector to have hook clamps fitted for the purpose of hanging.

safety chains

The use of a safety chain fixed to the **ProSpot LX** and to the primary suspension structure is highly recommended to protect against the accidental failure, however unlikely, of the primary suspension point.

If using an aftermarket safety chain not manufactured by **coemar**, ensure that it is of a sufficient rating to hold the weight of the unit.

The safety chain is attached by means of the two holes **B** located in the base of the unit as shown in the diagram.

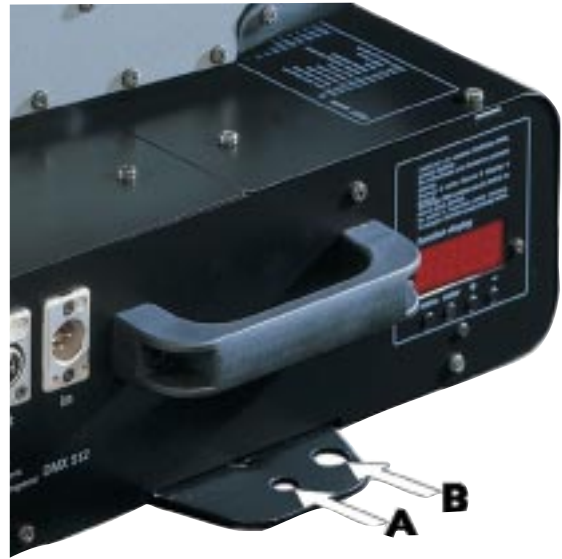

movement

The projector has an articulated movement of 530° in the base and 284° through its yoke; **DO NOT** obstruct the articulated movement in any way.

protection against liquids

The projector contains electric and electronic components that must not come into contact with water, oil, or any liquid.

risk of fire

Each fixture produces heat and must be installed in a well-ventilated position. The minimum recommended distance from flammable material is 0.5m. Minimum distance from the object being illuminated is 2m.

forced ventilation

You will note that the projector's housing contains several air entry points and fan outlets, positioned both on the head and the base of the unit; under no circumstances should any of these points be obstructed!

Obstruction of any of these points will result in the over-heating of the unit, detrimentally and seriously affecting the proper operation of the **ProSpot LX**.

On this point, refer to section **18 "Electronic motor alignment"**, subsection temperature (**temp**).

7. Mains connection

cable preparation

The mains cable provided is thermally resistant, complying with the most recent international standards.

NB: In case of cable replacement, similar cable with comparable thermal resistant qualities must be used exclusively (cable 3x1,5 ø external 8 mm, rated 300/500V, tested to 2KV, operating temperature -40° +180°).

mains connection

ProSpot LX can operate at voltages from 208V-230V-240V at 50 or 60Hz (operating voltage and frequency can be selected as described in section 5 and 16 of this manual). Prior to connecting the unit to your mains supply, ensure that the model in your possession correctly matches the mains supply available to you.

For connection purposes, ensure your plug is of a suitable rating: 2,1 amps at 245, 230v, 208V and 4,7 at 100 and 115V. Locate the mains cable, which exits the base of the unit and connect as shown below:

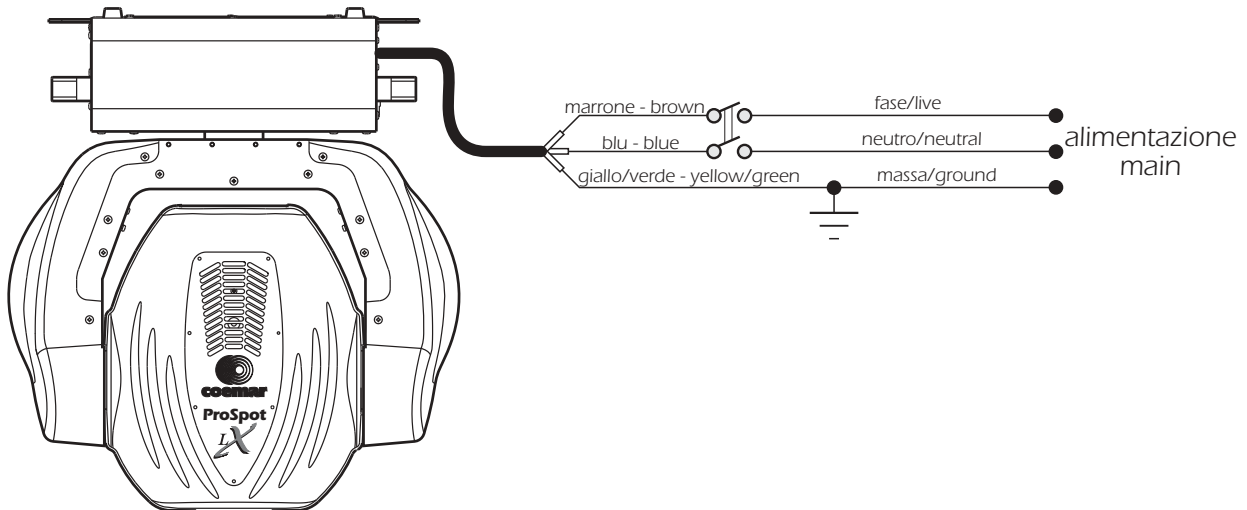

protection

The use of a thermal magnetic circuit breaker is recommended for each **ProSpot LX**.

A good earth connection is essential for the correct operation of the fixture. Strict adherence to regulatory norms is strongly recommended.

8. Signal connection

Control signal is digital and is transmitted via two pair screened $\varnothing 0,5$ cable.

Signal type is DMX 512, conforming to international standard; in order to reduce production costs and to allow easy worldwide availability of parts, coemar utilises XLR 3 plugs and sockets for signal connection. Pin connection conforms to international standards:

pin 1= screening 0 V

pin 2= data -

pin 3= data +

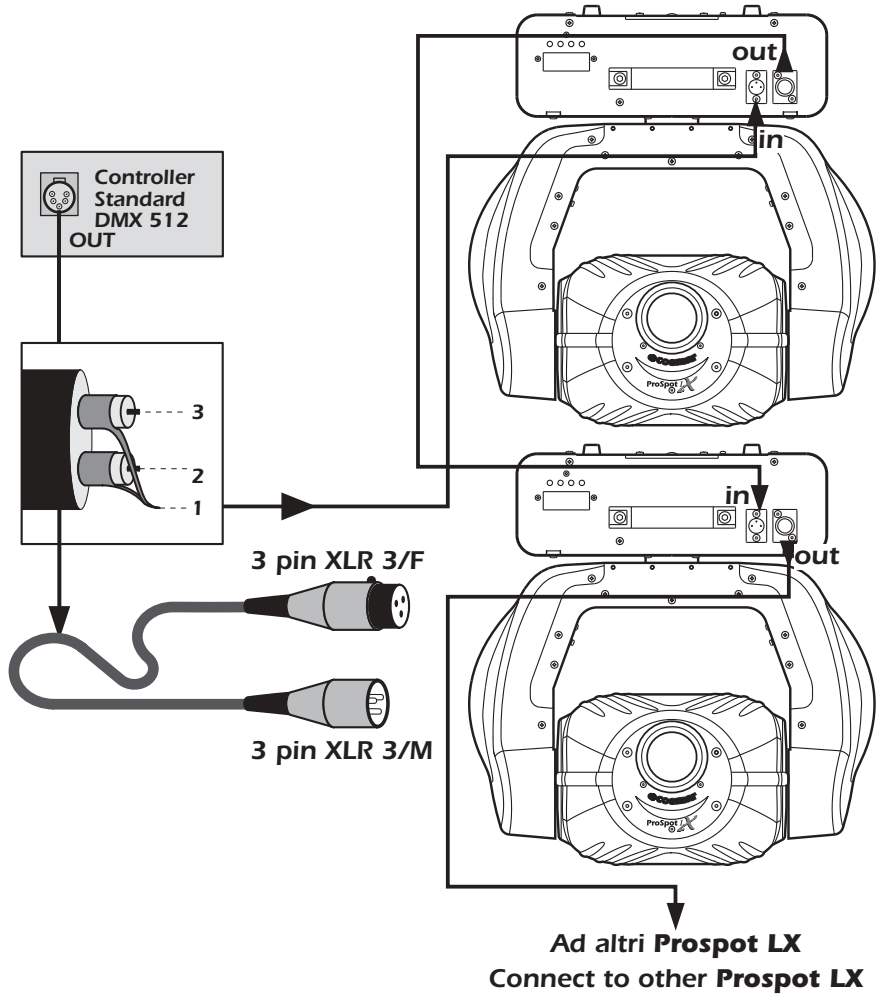

Should your DMX 512 controller utilise only XLR 5 sockets, the polarity of pins 1, 2 and 3 must be preserved as shown in the diagram. Do not connect pins 4 and 5.

pin 1= screening 0 volt
pin 2= data -
pin 3= data +

pin 4= not connected
pin 5= not connected

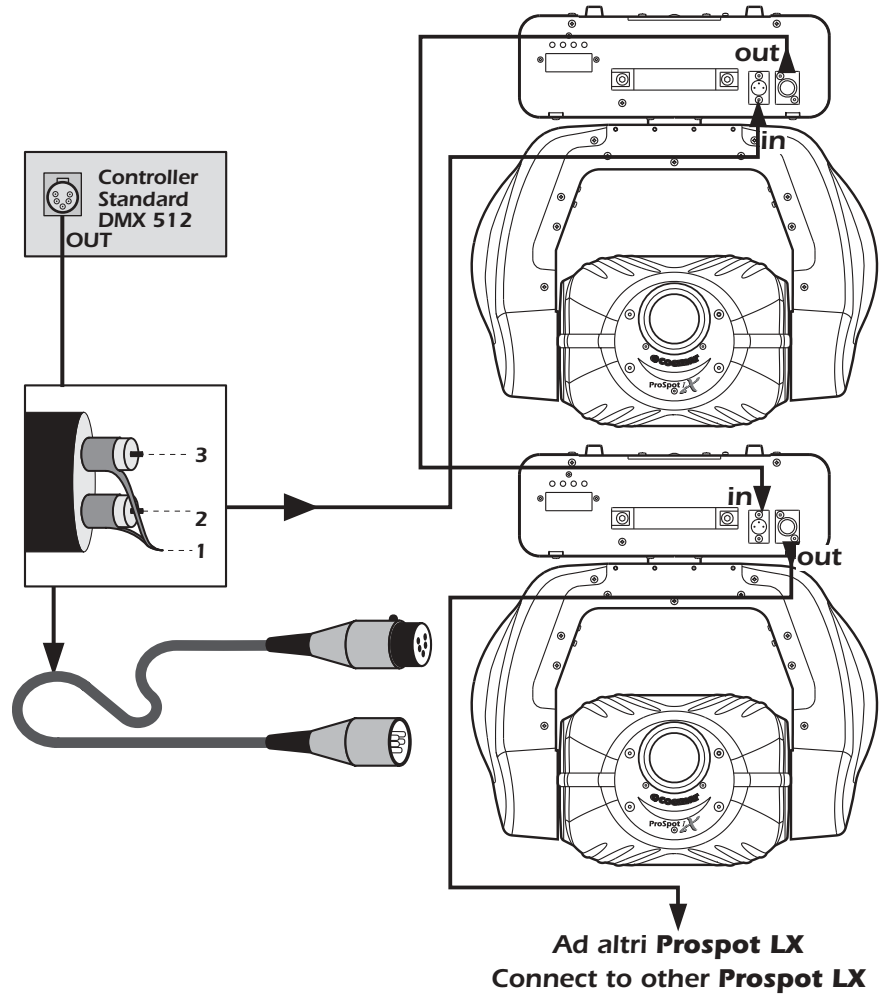

Ensure that all data conductors are isolated from one another and the metal housing of the connector.

Note: the housing of the cannon XLR 3 must be isolated.

9. Powering up

After having followed the preceding steps, turn on the DMX 512 controller which will be used to control the **ProSpot LX**; following this, turn on the power to the unit and turn on the unit's **power** switch. The projector will perform a reset function on all the internal and external motors. This will last some few seconds, after which it will be subject to the external signal from the controller.

DMX reception

The display will be static on to indicate that DMX 512 signal is being correctly received.

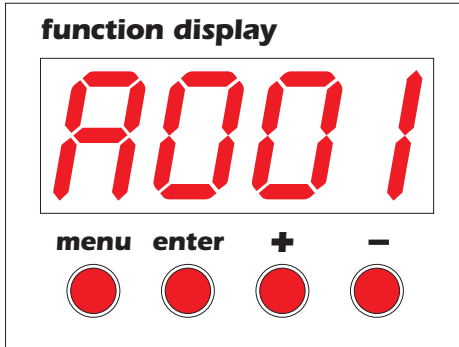

If the display flashes, the projector is not receiving signal. Check your cabling and the controller for correct functioning.

Software versions

Two software systems operate within the projector, one in the display system "D" and one in the master system "M". Upon startup, the projector's multifunction display panel will momentarily show readout of the software versions installed in your projector.

For example, in the **ProSpot LX** you may see:

D3.30 (display software "D" version 3.30).

M1.22 (master software "M" version 1.22.)

10. DMX addressing

Each **ProSpot LX** utilises **16** channels of **DMX 512** signal for complete control.

DMX addresses

To ensure that each projector accesses the correct signal, it is necessary to correctly address each fixture. Any number between 1 and 497 can be generated via the multifunction panel of the **ProSpot LX**.

This procedure must be carried out on every **ProSpot LX** being used.

When initially powered up, each projector will show **A001** indicating **DMX** address **1**. A projector thus addressed will respond to channels **1** to **16** from the **DMX 512** controller; a second unit should be addressed as **17**, a third as **33** and so on until the final **ProSpot LX**, has been addressed.

altering the dmx setting

- 1) Press the + or – buttons until the desired DMX address is displayed. The display will flash to indicate the selected address is not stored in memory

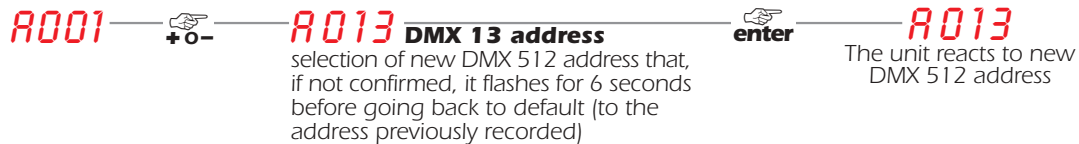









































- 2) Press the enter button to confirm your selection; the display will stop flashing and the projector will now respond to the new DMX 512 setting.
- 3) To better understand the function of each channel, we refer you to 12 "DMX 512 channel functions".

Important Note: Keeping the + or – buttons pressed will cause the display to alter at increased speed, allowing a faster selection to be effected.

11. Display panel functions

The display panel on the base of the **ProSpot LX** is used to display and set function information and various parameters and can enhance the operation of the projector to suit your particular application. Altering the coemar factory settings may vary the functioning of the projector, causing to not respond to external DMX 512 signal. Please read and familiarise yourself with the following information very carefully before altering any selections.

NOTE: the  symbol is used throughout the following table to indicate the action of pressing the particular button referred to in the accompanying text.

| | | | |
|--|--|--|---|
| ROO1  menu |  + o - PD IR pan movement inversion | enter  + o - | CW  enter |
| | To reverse horizontal movement direction of the beam on DMX level variation | | clockwise |
| | |  + o - | CCW  enter |
| | | | counter-clockwise |
|  + o - | TD IR tilt movement inversion | enter  + o - | CW  enter |
| | To reverse vertical movement direction of the beam on DMX level variation | | clockwise |
| | |  + o - | CCW  enter |
| | | | counter-clockwise |
|  + o - | OPTO optic sensor deactivation | enter  + o - | ON  enter |
| | Return in position of the unit if accidentally knocked out of place and ability to deactivate the function. Mechanical reset of the unit (opto OFF). | | sensors activation |
| | |  + o - | OFF  enter |
| | | | sensors deactivation |
|  + o - | LAMP lamp control | enter  + o - | STRD  enter |
| | Lamp on/off control by DMX signal or lamp always on | | lamp control by DMX 52 |
| | |  + o - | ON  enter |
| | | | lamp always on |
|  + o - | FANS fans control | enter  + o - | ON  enter |
| | Fans always on (on) or fans function controlled through PCB (Stud). | | fans always on |
| | |  + o - | STUD  enter |
| | | | automatic control |
|  + o - | DISP reverse display | enter  + o - | RR  enter |
| | Reverse reading display (base downwards or base upwards) | | base downwards |
| | |  + o - | UU  enter |
| | | | reversed, base upwards |
|  + o - | LED display control | enter  + o - | OFF  enter |
| | To disable display visualisation | | to switch off the display ( any keys to switch it on) |
|  + o - | DMX DMX chart | enter  + o - | STRD  enter |
| | To select function mode on DMX data reception | | standard 16 channel (see diagram) |
| | |  + o - | EMUL  enter |
| | | | emulation ProSpot (not LX version - see diagram) |

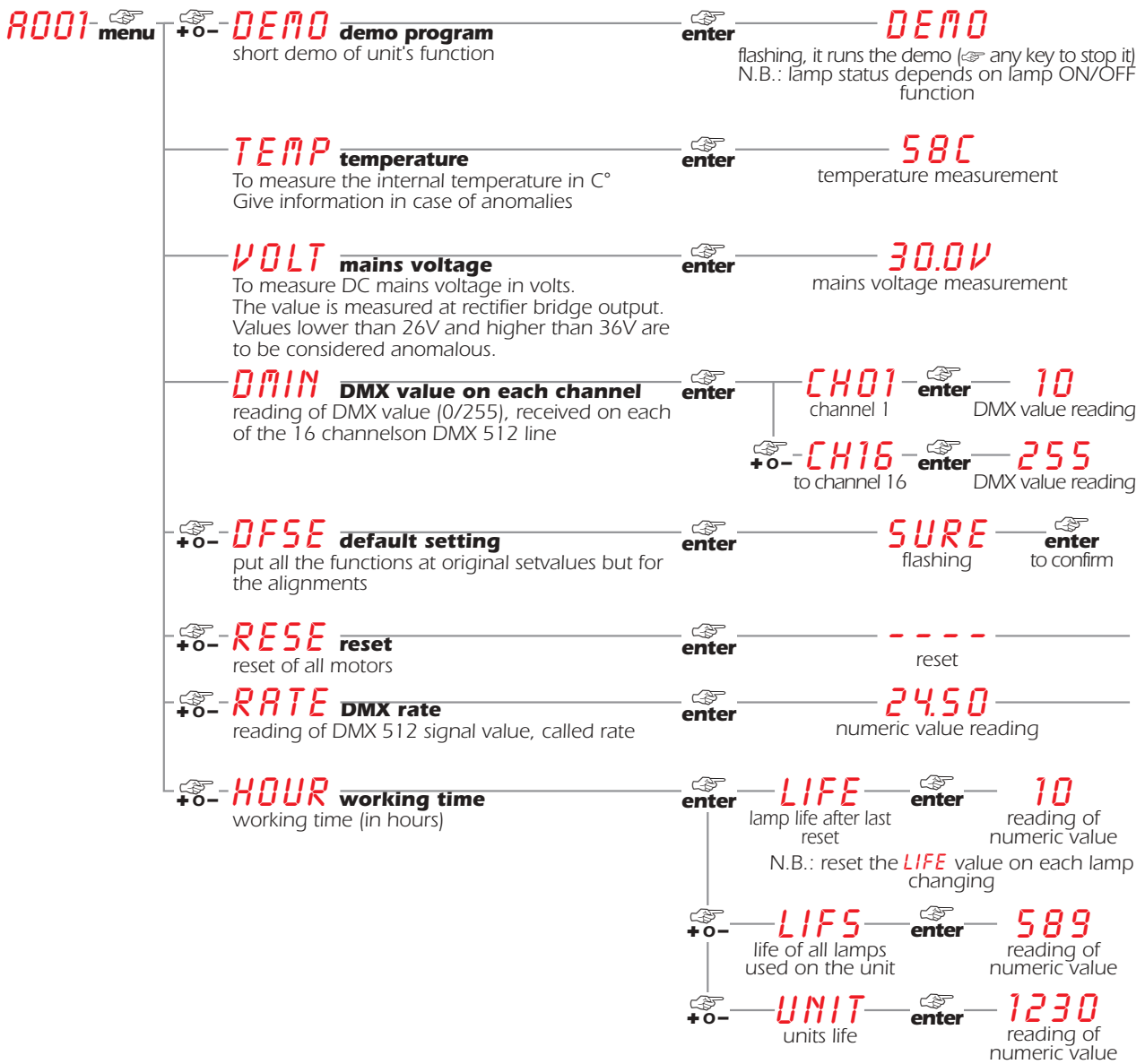

11.1. Turning on the ProSpot LX without articulated movement

This function may be useful should you need to turn on the **ProSpot LX**, whilst it is still in its flight case or located in cramped conditions in order to alter its dmX address setting or adjust some other parameter.

1) Turn on the projector whilst simultaneously holding down the **menu**, **enter** and **-** buttons.

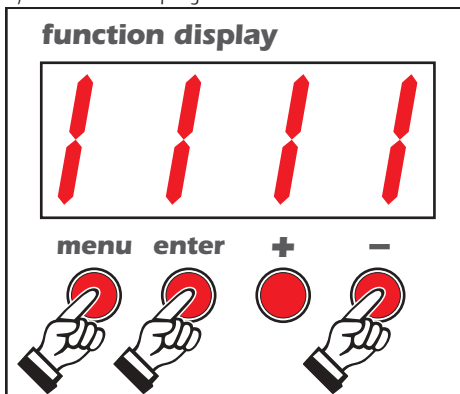

The projector will undertake a reset of all motors except those, which govern pan and tilt movement.

- 2) You may alter the dmX address or any other parameter at this point without any movement occurring.
- 3) To reactivate the normal functioning of the **ProSpot LX**, you need simply to turn the projector off and then on again via its **power** button, or simply perform a reset.

English

11.2. Resetting the electronic lamp life counter

The electronic lamp life counter should be reset to zero at every lamp change in order to provide accurate lamp life information.

- 1) Turn off the projector.
- 2) Power up the **ProSpot LX** whilst simultaneously holding down the **+** and **-** buttons.

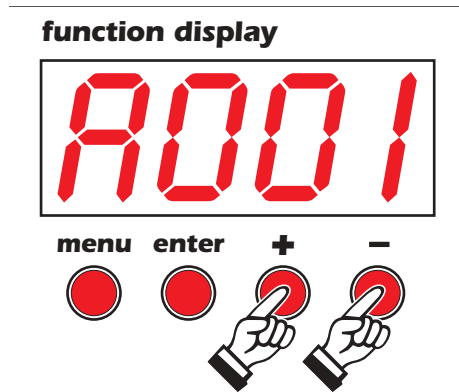

The projector will have performed a reset of the **LIFE** counter. To check that this has occurred you may complete the following steps:

- 1) Press the **menu** button.
 - 2) Press the **+** or **-** buttons until **hour** is displayed.
 - 3) Press the **+** or **-** buttons until **LIFE** (for lamp life) is displayed.
 - 4) Press the **enter** button; the display will show **0000** confirming that a reset of the counter has occurred.
- N.B. You may also confirm if you choose that the **LIFE UNIT** and **UNIT** counters remain unaltered.

11.3. test

This function generates a test signal for each motor so that they can be tested in the absence of any external DMX source.

- 1) Press the **menu** button.
- 2) Press the **+** or **-** buttons until **TEST** (for test) is displayed.
- 3) Press the **enter** button to confirm your selection; the display will show **PAN** (for testing the pan movement), press the **+** or **-** subsequent tests, from **PAN** to **COLR**.

| | | | | | | | | | | | | | |
|-------------|---|-------------|----------------|---|--------------|---|-------------|----------------------|---|--------------|-------------|---|---|
| A001 | → | TEST | test | → | enter | → | PAN | pan movement test | → | enter | 0128 | → | The unit performs the motors test. To speed up the test procedure and to reach directly the 255 , press first the + key together with - key while to reach the value 0 press first the - key together + key |
| | | | Functions test | | | | | | | | | | |
| | | | | | | | TILT | tilt movement test | | | | | |
| | | | | | | | DIMM | dimmer test | | | | | |
| | | | | | | | SHUT | test dell'otturatore | | | | | |
| | | | | | | | FOCU | focusing test | | | | | |
| | | | | | | | GOBO | gobos test | | | | | |
| | | | | | | | G.RO | gobo rotation test | | | | | |
| | | | | | | | PRIS | prisms test | | | | | |
| | | | | | | | PRRO | prisms rotation test | | | | | |
| | | | | | | | COLR | colors test | | | | | |

12. DMX 512 channel functions

If all the procedures have been carried out correctly to this point, your DMX 512 controller will have control over all the functions of the **ProSpot LX** as shown in the table below.

| channel | function | type of control | effect | decimal |
|--|---------------------------------------|-----------------|--|----------|
| 1 | Base (pan) coarse | proportional | coarse control of the base movement | 0-255 |
| 2 | Base (pan) fine | proportional | fine control of the base movement | 0-255 |
| 3 | Yoke (tilt) coarse | proportional | coarse control of the Yoke movement | 0-255 |
| 4 | Yoke (tilt) fine | proportional | fine control of the Yoke movement | 0-255 |
| 5 | movement speed | step | standard (fast) | 0-10 |
| | | step | Ultra fast movement (best for programming position) | 11-25 |
| | | proportional | vector mode from fast to slow | 26-127 |
| | | proportional | Tracking mode (fast to slow) | 128-247 |
| | | step | Tracking mode (slow) | 248-255 |
| 6 | dimmer | step | closed | 0-7 |
| | | proportional | Gradual adjustment of the dimmer intensity from 0 to 100% | 8-255 |
| 7 | Shutter, Strobe | step | Shutter closed | 0-9 |
| | | proportional | Synchro strobe-effect from slow to fast (max. 10 flashes/second) | 10-66 |
| | | step | Shutter open | 67-68 |
| | | proportional | Pulse-effect in sequences, close slow, open fast (adjustement from slow to fast) | 69-125 |
| | | step | Shutter open | 126-127 |
| | | proportional | Pulse-effect in sequences, close fast, open slow (adjustement from fast to slow) | 128-184 |
| | | step | Shutter open | 185-187 |
| | | proportional | Random strobe-effect from slow to fast | 188-244 |
| step | Shutter open | 245-255 | | |
| 8 | focus | proportional | proportional focus control | 0-255 |
| 9 | Rotating gobos, selection | step | Open | 0-10 |
| | | step | Rot. gobo 1 | 11-30 |
| | | step | Rot. gobo 2 | 31-50 |
| | | step | Rot. gobo 3 | 51-70 |
| | | step | Rot. gobo 4 | 71-90 |
| | | step | Rot. gobo 5 | 91-110 |
| | | step | Rot. gobo 6 | 111-127 |
| | | proportional | From no gobo to gobo 6, 360° gobo positioning | 128-192 |
| proportional | Gobo wheel rotation from slow to fast | 193-255 | | |
| 10 | gobo 360° positioning | step | no effect | 0-10 |
| | | proportional | proportional indexable gobo positioning 360° | 11-255 |
| NOTE: when channel 10 is between 0 and10, channel 11 stop the rotation without indexing the gobo | | | | |
| 11 | gobo rotation | step | no effect | 0-10 |
| | | proportional | continuous gobo rotation clockwise with proportional speed from fast to slow | 11-131 |
| | | step | gobo stop | 132-134 |
| | | proportional | continuous gobo rotation counter-clockwise with proportional speed from slow to fast | 135-255 |
| 12 | 3 facet prism & rotation | step | no prism | 0-10 |
| | | step | 3 facet prism | 11-20 |
| | | proportional | continuous prism rotation clockwise with proportional speed from fast to slow | 21-136 |
| | | step | prism stop | 137- 139 |
| | | proportional | continuous prism rotation counterclockwise with proportional speed from slow to fast | 140-255 |

English

| channel | function | type of control | effect | decimal |
|--|--|-----------------|--|---------|
| 13 | colours | step | Open/white | 0 |
| | | step | colour 1 | 5-9 |
| | | step | colour 2 | 10-14 |
| | | step | colour 3 | 15-19 |
| | | step | colour 4 | 20-24 |
| | | step | colour 5 | 25-29 |
| | | step | colour 6 | 30-34 |
| | | step | colour 7 | 35-39 |
| | | step | colour 8 | 40-44 |
| | | step | colour 9 | 45-49 |
| | | step | colour 10 | 50-54 |
| | | step | colour 11 | 55-59 |
| | | proportional | From white to colour 11, 360° color positioning | 60-127 |
| | | proportional | Forwards rainbow effect from fast to slow | 128-190 |
| step | No rotation | 191-192 | | |
| proportional | Backwards rainbow effect from slow to fast | 193-255 | | |
| 14 | gobo shake and black-out effect | step | No effect | 0-9 |
| | | proportional | gobo shake slow to fast | 10-249 |
| | | step | Black-out while PAN,TILT moving, color or gobo changes | 250-255 |
| 15 | gobo shake amplitude | step | gobo shake maximum size | 0-23 |
| | | step | gobo shake size 2 | 24-47 |
| | | step | gobo shake size 3 | 48-71 |
| | | step | gobo shake size 4 | 72-95 |
| | | step | gobo shake size 5 | 96-119 |
| | | step | gobo shake size 6 | 120-143 |
| | | step | gobo shake size 7 | 144-167 |
| | | step | gobo shake size 8 | 168-191 |
| | | step | gobo shake size 9 | 192-215 |
| | | step | gobo shake size 10 | 216-239 |
| step | gobo shake minimum size | 240-255 | | |
| 16 | Lamp ON, motor Reset | step | lamp off | 0-19 |
| | | step | no effects (idle) | 20-100 |
| | | step | effects reset (only once), pan/tilt does not move | 101-170 |
| | | step | all motor reset (only once) | 171-200 |
| | | step | silent fans (if external temperature allowed) | 201-240 |
| | | step | Lamp ON | 241-255 |
| Back panel can modify function channel (16) (inhibit lamp off) | | | | |
| note 1: function channel (16) has a delay time of 6 second to prevent accidental activation. | | | | |
| note 2 :on/off lamp mode is not affected unless an opposite value is received | | | | |

ProSpot emulation setting

ProSpot LX may operate using a different channel configuration to the standard set up. This function may be useful in situations where you may be using other ProSpot projector which are not in the LX series or when using various controllers with inflexible channel assignment features. To utilise this altered configuration as shown in the table, which follows, you should:

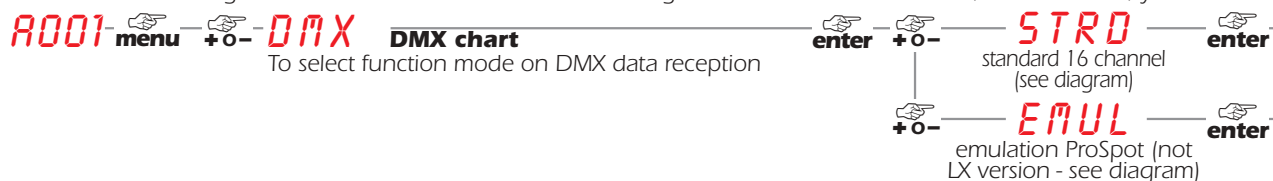

Following is the ProSpot emulation table.

| channel | function | type of control | effect | decimal |
|---------------|---|-----------------|--|---------|
| 1 | Base (pan) coarse | proporzionale | coarse control of the base movement | 0-255 |
| 2 | Yoke (tilt) coarse | proporzionale | coarse control of the Yoke movement | 0-255 |
| 3 | Base (pan) fine | proporzionale | fine control of the base movement | 0-255 |
| 4 | Yoke (tilt) fine | proporzionale | fine control of the Yoke movement | 0-255 |
| 5 | Speed pan/tilt movement | livello unico | Max speed (tracking mode) | 0 |
| | | proporzionale | Max speed from max. to min. vector mode) | 1-249 |
| | | livello unico | Max. speed, black-out while PAN,TILT moving or color changes (tracking mode) | 250-255 |
| 6 | lamp on/off, reset, fans speed control | livello unico | open, max. speed of fan | 0 |
| | | proporzionale | open, min. speed of fan (silent operation) from 0 to 127 decreasing speed of fan | 1-127 |
| | | livello unico | Lamp ON, reset, open position | 128-139 |
| | | livello unico | No function | 140-229 |
| | | livello unico | Lamp Off after 3 sec. | 230-239 |
| | | livello unico | No function | 240-255 |
| 7 | colours | proporzionale | Open/white | 0 |
| | | proporzionale | colour 1 | 10 |
| | | proporzionale | colour 2 | 21 |
| | | proporzionale | colour 3 | 32 |
| | | proporzionale | colour 4 | 42 |
| | | proporzionale | colour 5 | 53 |
| | | proporzionale | colour 6 | 64 |
| | | proporzionale | colour 7 | 74 |
| | | proporzionale | colour 8 | 85 |
| | | proporzionale | colour 9 | 96 |
| | | proporzionale | colour 10 | 106 |
| | | proporzionale | colour 11 | 117 |
| | | proporzionale | Forwards rainbow effect from fast to slow | 128-189 |
| livello unico | No rotation | 190-193 | | |
| proporzionale | Backwards rainbow effect from slow to fast | 194-255 | | |
| 8 | no function | livello unico | No function | 0-255 |
| 9 | effect-wheel | livello unico | Open position (hole) | 0-95 |
| | | livello unico | 3 - facet rotating prism | 96-159 |
| | | livello unico | Prism/Gobo macros | 160-255 |
| | | livello unico | Macro 1 | 160-167 |
| | | livello unico | Macro 2 | 168-175 |
| | | livello unico | Macro 3 | 176-183 |
| | | livello unico | Macro 4 | 184-191 |
| | | livello unico | Macro 5 | 192-199 |
| | | livello unico | Macro 6 | 200-207 |
| | | livello unico | Macro 7 | 208-215 |
| | | livello unico | Macro 8 | 216-223 |
| | | livello unico | Macro 9 | 224-231 |
| | | livello unico | Macro 10 | 232-239 |
| livello unico | Macro 11 | 240-247 | | |
| livello unico | Macro 12 | 248-255 | | |

English

| channel | function | type of control | effect | decimal |
|-----------|---|-----------------|---|---------|
| 10 | 3 facet prism rotation control | livello unico | No rotation | 0 |
| | | proporzionale | Forwards rotation from fast to slow | 1-126 |
| | | livello unico | No rotation | 127-128 |
| | | proporzionale | Backwards rotation from slow to fast | 129-255 |
| 11 | Rotating gobos, selection | livello unico | Open | 0-31 |
| | | livello unico | Rot. gobo 1 | 32-63 |
| | | livello unico | Rot. gobo 2 | 64-95 |
| | | livello unico | Rot. gobo 3 | 96-127 |
| | | livello unico | Rot. gobo 4 | 128-159 |
| | | livello unico | Rot. gobo 5 | 160-191 |
| | | livello unico | Rot. gobo 6 | 192-223 |
| | | livello unico | Rot. gobo wheel cont. rotation slow to fast | 224-255 |
| 12 | Gobo rotation & fine positioning | proporzionale | Gobo indexing | 0-127 |
| | | proporzionale | Forwards gobo rotation from fast to slow | 128-190 |
| | | livello unico | No rotation | 191-192 |
| | | proporzionale | Backwards gobo rotation from slow to fast | 193-255 |
| 13 | no function | | no function | 0-255 |
| 14 | Focus | proporzionale | Proportional focus control | 0-255 |
| 15 | Shutter, Strobe | livello unico | Shutter closed | 0-31 |
| | | livello unico | No function (Shutter open) | 32-63 |
| | | proporzionale | Strobe-effect from slow to fast (max. 10 flashes/second) | 64-95 |
| | | step | No function (Shutter open) | 96-127 |
| | | proporzionale | Pulse-effect in sequences | 128-159 |
| | | step | No function (Shutter open) | 160-191 |
| | | proporzionale | Random strobe-effect from slow to fast | 192-223 |
| | | step | No function (Shutter open) | 224-255 |
| 16 | Dimmer intensity | proporzionale | Gradual adjustment of the dimmer intensity from 0 to 100% | 0-255 |

13. Aligning the lamp in the optical system

Alignment is necessary to compensate for the slight variations in the mechanical construction of respective lamps due to the fact that may discharge lamps are still partly constructed manually.

The procedure should be undertaken to properly align the lamp in the optical system, thus avoiding the possible overheating of internal components due to incorrect focusing of the beam onto components which are not designed to be exposed to this.

Alignment procedure

Manipulating the two adjusters **A** and **B** contemporaneously effects alignment; with the lamp on and blackout shutter dimmer and no filters placed in the optical path. The procedure flattens the beam to produce an even beamspread

Axial adjustment

Adjuster (**A**) acts on a lever and spring assembly to position the lamp axially within the reflector. Rotate the adjuster (**A**) until the beam produced is flat and even.

Horizontal adjustment

Adjuster (**B**) acts on a lever and spring assembly to position the lamp horizontally within the reflector. Rotate the adjuster (**B**) until the beam produced is as required.

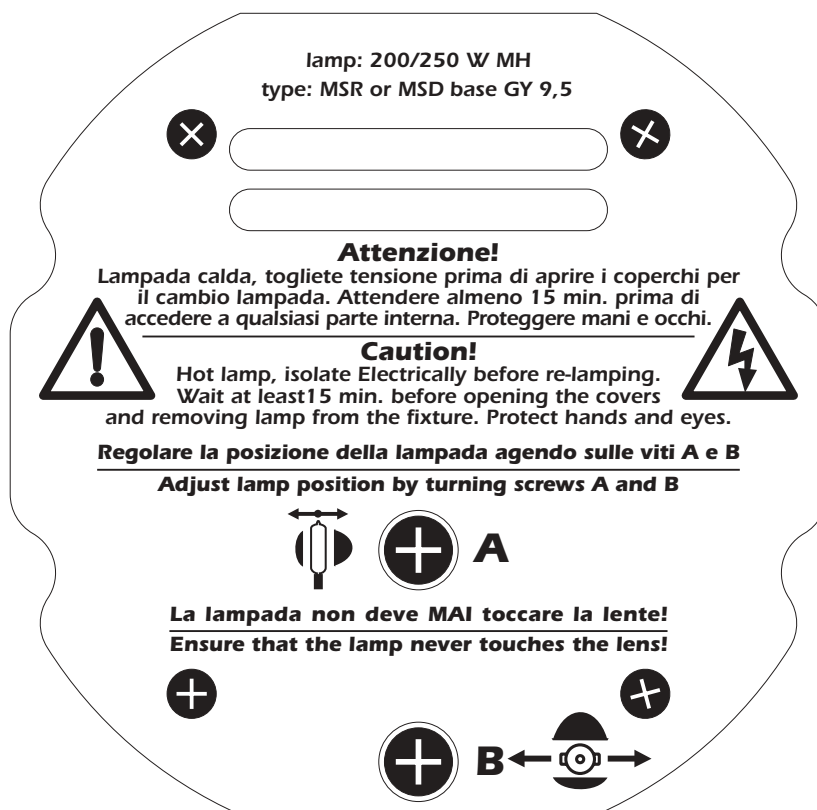

14. Automatic repositioning features

An encoder system based on 4 position indicators allows the **ProSpot LX** to return to its correct position if it is accidentally moved during operation. This is particularly useful if the projector is to be mounted on the floor in a position where the performer or artist or technician may accidentally bump the unit.

R001 — menu — + 0 — **OPTO** — optic sensor deactivation — enter — + 0 — **ON** — sensors activation — enter — + 0 — **OFF** — sensors deactivation — enter

Return in position of the unit if accidentally knocked out of place and ability to deactivate the function. Mechanical reset of the unit (opto OFF).

15. Gobo replacement

ProSpot LX allows gobos to be replaced via a simple gobo retention spring system. Replacement gobos should be manufactured from either dichroic glass or metal. The **coemar** reseller network carries a wide range of replacement gobos.

Opening up the projector:

- Using a Phillips head screwdriver, remove the four screws located at both the front and rear of the projector head which affix the top housing and those for the bottom housing, as shown in the diagram below:

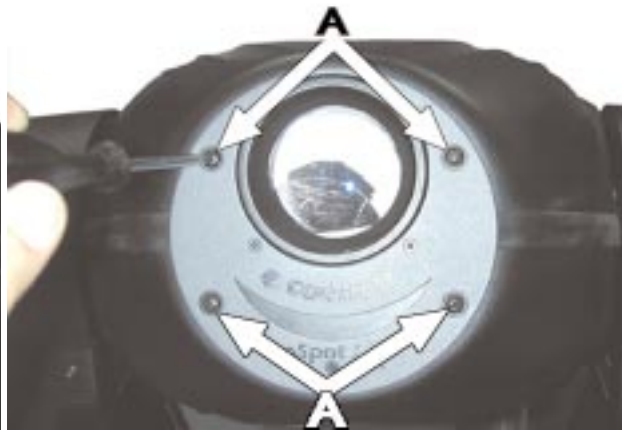
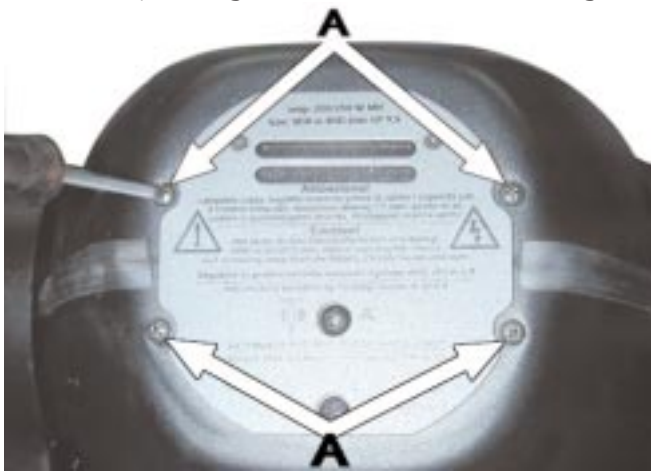

Replacing gobos on the rotating gobo wheel

Gobos may be replaced as required to produce special effects as required.

Gobo replacement should always be carried out with the power to the unit shut off and the housing removed as describe in section 16 "Maintenance".

- Rotate the gobo wheel until you locate the gobo you wish to remove.



- Remove the retaining spring and remove and replace the gobo.

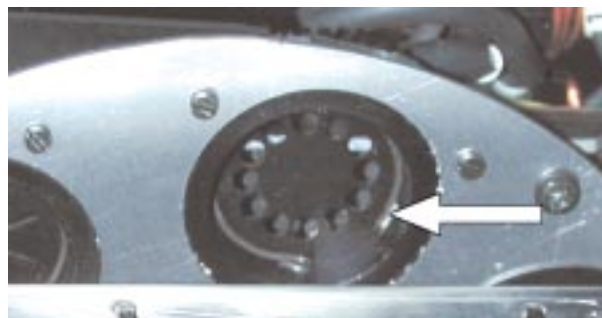

- Replace the retaining spring, ensuring that it is seated correctly.

16. Altering the operating voltage and frequency (Reserved for technical staff only)

If the operating voltage and frequency as preset by coemar does not correspond to that of the country in which you are operating, you may alter the preset by following the instructions in the paragraphs which follow.

An error in voltage or frequency selection may seriously compromise the correct functioning of the projector.

16.1 Selecting the voltage on the autotransformer

1) Using a Philips head screwdriver, remove the 6 screws (A) on the lateral cover of the fixture's base as shown in the diagram below, thereby removing the cover and obtaining access to the internal features of the **ProSpot LX** base.

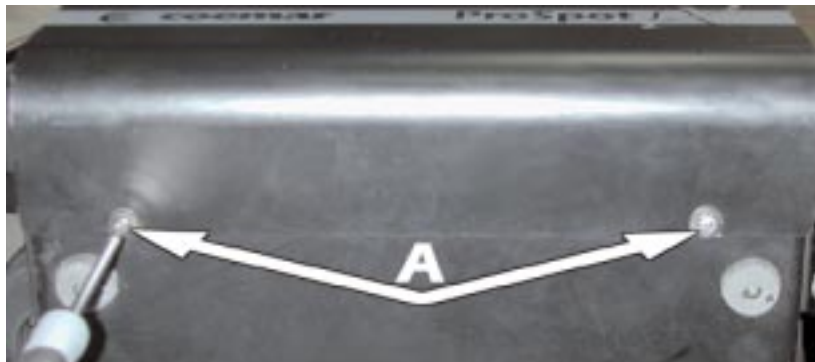
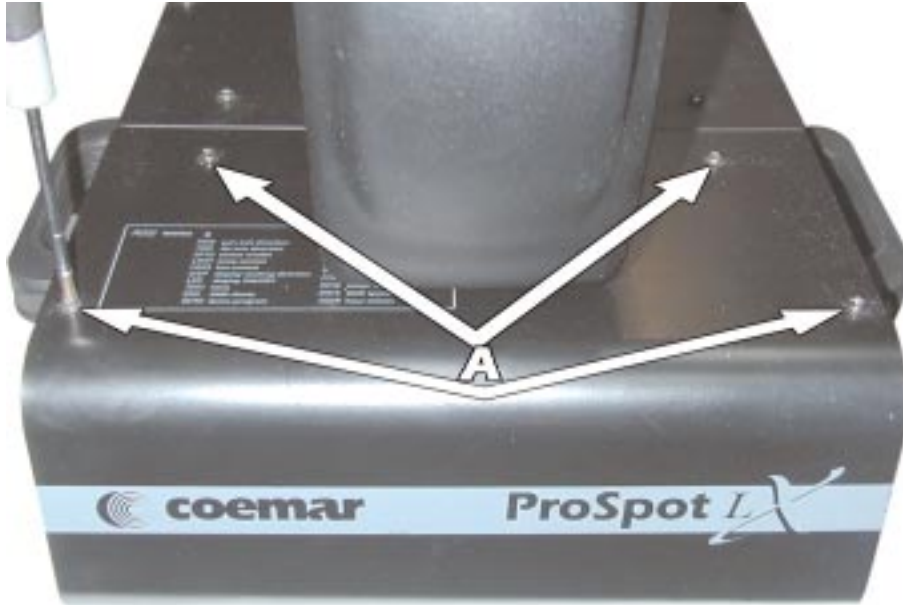

2) Locate the autotransformer (B) on the right of the base.

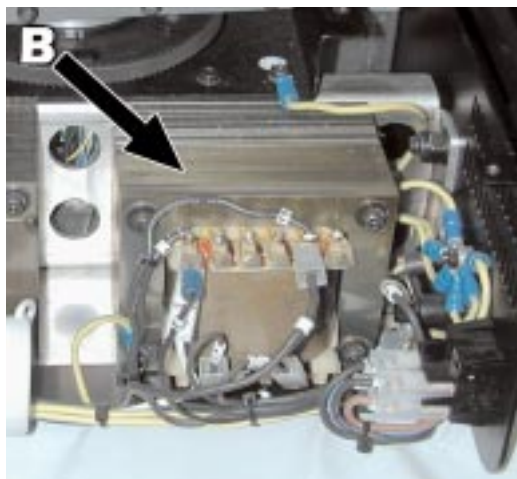

English

- 3) Select the operating voltage from the 100, 115, 208, 230 and 245V options by moving the cable n° 7 to the required voltage. To ensure correct positioning of the cable, refer to the label located on the transformer.



- 4) If the voltage is altered to either 100 or 115V replace the current fuse rated at 5 Amps T, which is suitable for 208/230/245 V, with a fuse rated at 8 Amps T. The fuse holder is located on the side of the base of the unit. The reverse should be undertaken if the voltage is being increased to the latter range.

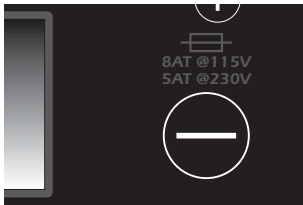

- 5) Proceed to the selection of the proper frequency, as described in the following section, and then replace the cover and refasten the screws (A).

16.2 Selecting the frequency on the power supply of the ProSpot LX

- 1) Locate the power supply (A) located in the base of the unit.

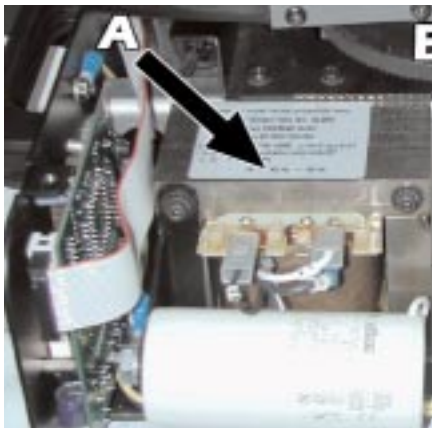

- 2) Select the required frequency from between 50 and 60Hz by moving cable n° 11 to the correct option. To ensure correct positioning of the cable, refer to the label located on the power supply.



- 4) Replace the cover and refasten the screws (A).

17. Maintenance

Whilst every possible precaution has been taken to ensure the trouble-free operation of your **ProSpot LX**, the following periodic maintenance is highly recommended. Prior to undertaking any maintenance procedure, make sure the fixture is disconnected from mains power.

Attention

Disconnect mains power prior to opening the housing!

Opening the housing:

- Using a Phillips head screwdriver, remove the four screws located at both the front and rear of the projector head which affix the top housing and those for the bottom housing, as shown in the diagram below:



Fuse replacement

Locate the 3 protection fuses:

Two are located on the master circuit board and protect the lamp circuit and the electronics. A third is located externally on the side of the base of the projector and offers protection to the entire projector.

Use a multimeter to check the condition of the fuses, replacing them with fuses of similar value if required.

Periodic cleaning Lenses and reflectors

Even a fine layer of dust can reduce the luminous output substantially. Regularly clean all lenses and the reflector using a soft cotton cloth, dampened with a specialist cleaning solution.

Fans and air passages

The fans and air passages must be cleaned approximately every 6 weeks; the period for this cleaning will depend, of course, upon the conditions in which the projector is operating. Suitable instruments for performing this type of maintenance are a brush and a common vacuum cleaner or an air compressor.

Periodic maintenance Lamp

The lamp should be replaced if there is any observable damage or deformation due to heat. This will avoid the danger of the lamp exploding.

Mechanicals

Periodically check all mechanical devices for wear and tear; gears, guides, belts, etc, replacing them if necessary. Periodically check the lubrication of all components, particularly the parts subject to high temperatures. If necessary, lubricate with a suitable lubricant, available from your coemar distributor.

Electrical components

Check all electrical components for correct earthing and proper attachment of all connectors, refastening if necessary.

18. Electronic alignment of motors

Attention

These procedures should only be carried out by qualified technicians or other specialists

The display panel on the **ProSpot LX** allows for the electronic alignment of the projector's motors. This procedure is performed by **coemar** at the factory. It may be useful to perform this procedure in the case of internal components being replaced. Altering the factory settings may radically alter the functioning of the projector. Carefully read all of the following prior to attempting any changes.

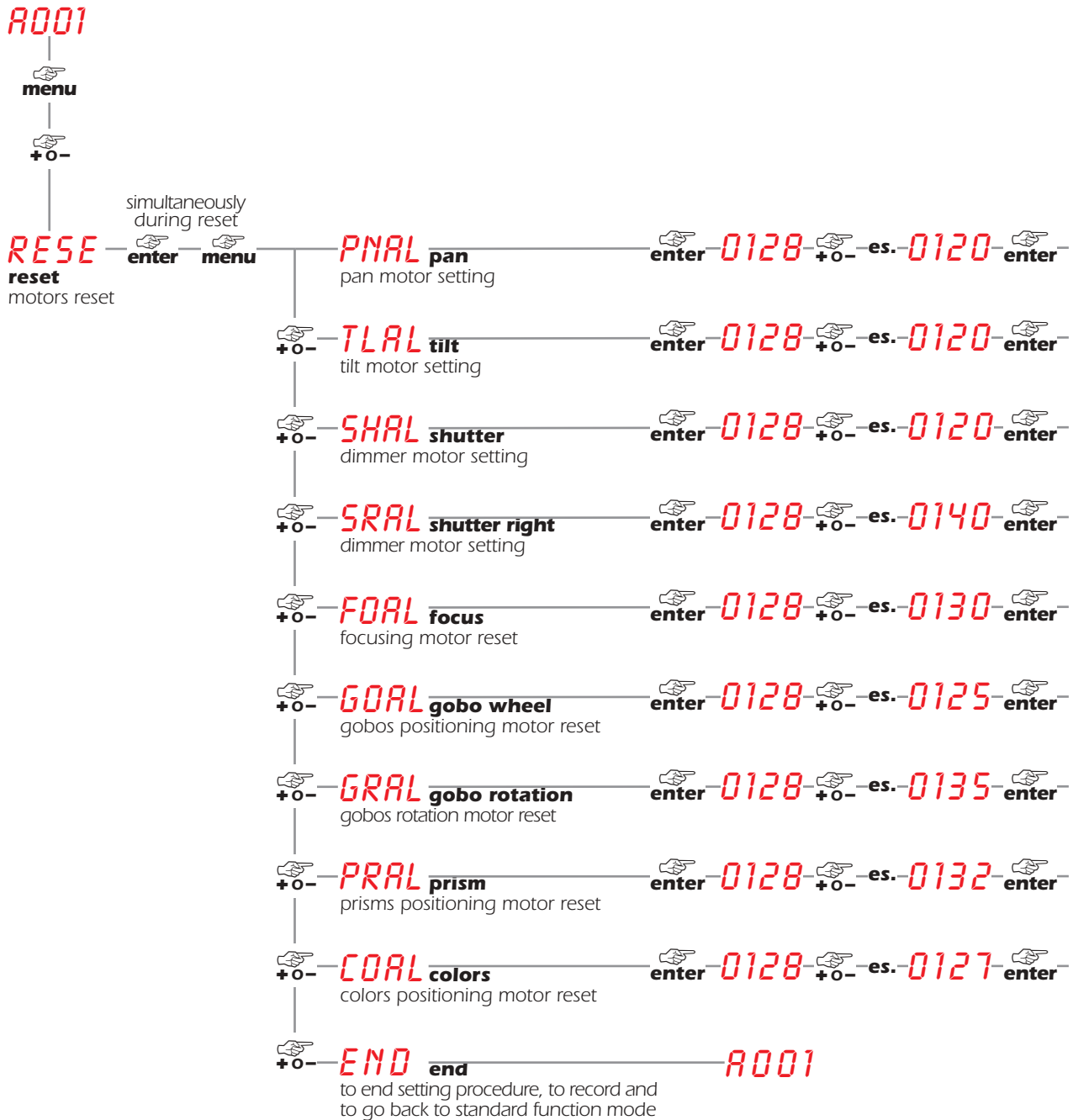

simultaneously



NOTE:

To speed up setting/alignment procedure, press simultaneously keys + and -; the display will automatically go to 128

19. Error messages

| | |
|---------------------|---|
| MBER: | COMMUNICATION error This message indicates that the motherboard within the unit is not communicating properly with the control source. Check the connectors located on both boards. |
| OPER: | PAN ENCODER error This message indicates that there is a problem with the PAN encoders. Check the sensors on the encoder wheel located near the pan movement motor, as well as the relevant cabling. |
| OTER: | TILT ENCODER error This message indicates that there is a problem with the TILT encoder locate on the fixture yoke. Check the sensors on the encoder wheel located near the pan movement motor, as well as the relevant cabling. |
| SNER: | LINE SYNCHRONISATION error Check and replace opto-isolator U9. |
| LAER: | LAMP error The lamp has turned off unexpectedly, without any signal from the controller to do so. The system may have exceeded the allowable number of attempts to ignite the lamp (7) after which number the system is designed to protect ignitor, cabling and the lampholder by reducing the incidence of lamp ignition voltages to these components. Check and eventually replace the lamp if it is faulty, damaged, or has exceeded its lamp life. |
| EPER: | EEPROM error The EEPROM is either defective or absent; refer to your coemar service centre for a replacement component. |
| OTER: | DATA error The initial parameter settings are incorrect or corrupt; the projector has reloaded its factory default settings. Turn the projector off and on again. Should the error reoccur, refer the unit to your authorised coemar service centre to have the EEPROM check and possibly replaced. |
| SCER: | COLOUR SENSOR CIRCUIT error Check the cabling and the sensor on the COLOUR wheel, the sensor and circuit board indicate an error. |
| SGER: | GOBO and PRISM SENSOR CIRCUIT error Check the cabling and the sensor on the GOBO and PRISM wheel, the sensor and circuit board indicate an error. |
| COER: | COLOUR WHEEL POSITION error Check the functioning and correct positioning of the magnetic colour wheel sensor. |
| RGER: | GOBO WHEEL POSITION error Check the functioning and correct positioning of the magnetic gobo wheel sensor. |
| IGER: | GOBO INDEXING error Check the functioning and correct positioning of the gobo indexing sensor. |
| PRER: | PRISM INSERTION error Check the functioning and correct positioning of the prism insertion sensor. |
| ER20 ÷ ER99: | SYSTEM errors Turn the unit off and on again. If the error persists, contact your authorised coemar service centre. |
| HEAT: | LAMP OVERHEAT indicator The projector is attempting to ignite a lamp, which is still too hot to strike. Wait until the lamp has cooled further and then attempt to reignite the lamp. |

20. Spare parts

All the components of the **ProSpot LX** are available as replacement parts from your authorised **coemar** sales agent. Accurate description of the fixture, model number, and type will assist us in providing for your requirements in an efficient and effective manner.