

# PinSpot

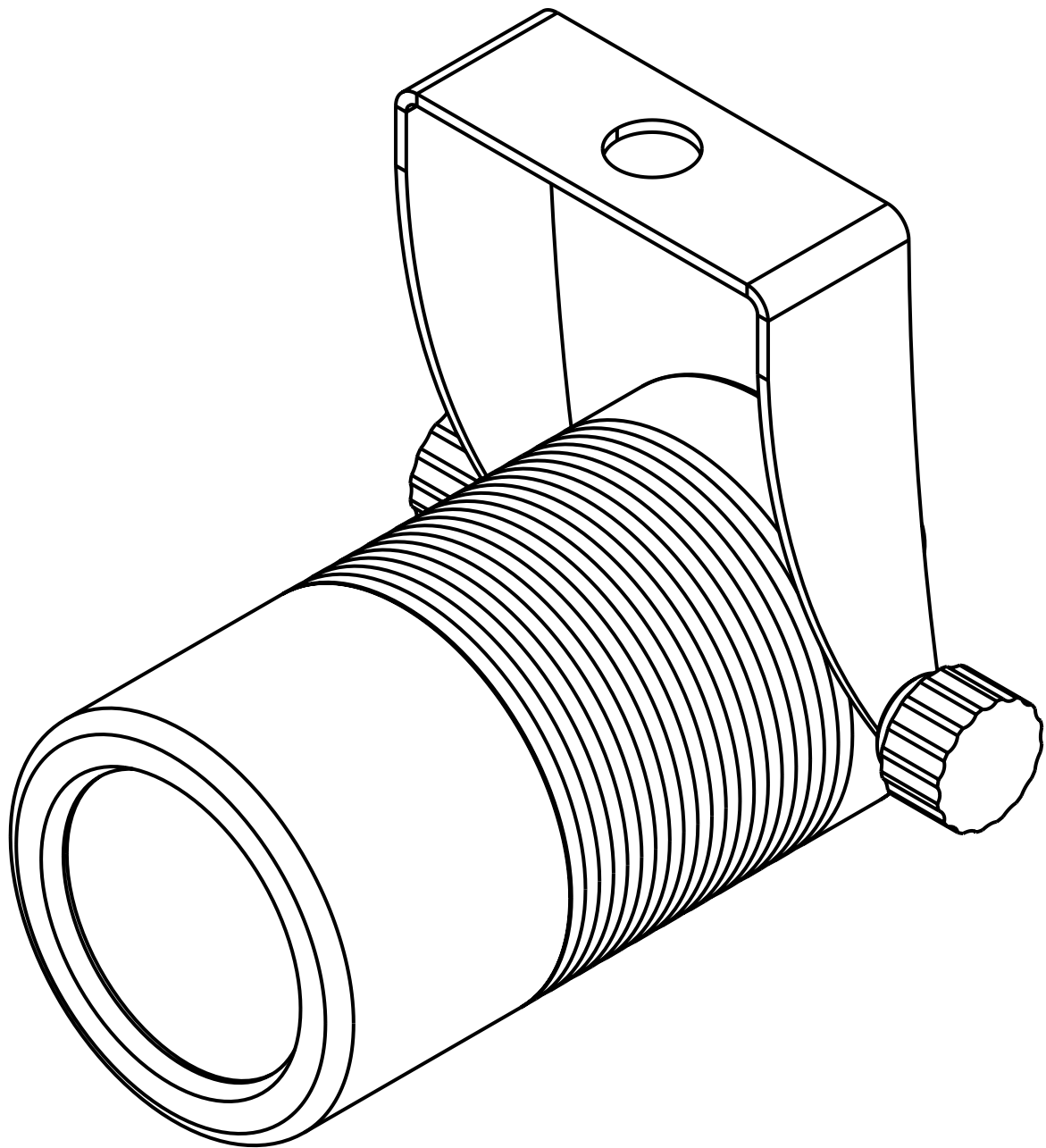

# PinSpot

Serial Number:

.....

Purchase date:

.....

Dealer:

.....

Address:

.....

Suburb:

.....

Country:

.....

Phone / Fax:

.....

Please note in the space provided above the relative service information of the model and the retailer from whom you purchased your **PinSpot**: this information will assist us in providing spare parts, repairs or in answering any technical enquiries with the utmost speed and accuracy.

**WARNING:** the security of the fixture is granted only if these instructions are strictly followed; therefore it is absolutely necessary to keep this manual.

# Indice

<b>1. Packaging and transportation</b> .....	Pag. 4
<b>1.1</b> Packaging .....	Pag. 4
<b>1.2</b> Transportation .....	Pag. 4
<b>2. General information</b> .....	Pag. 4
<b>2.1</b> Safety informations .....	Pag. 4
<b>2.2</b> Warranty conditions .....	Pag. 5
<b>2.3</b> EC norms .....	Pag. 5
<b>3. Product specifications</b> .....	Pag. 6
<b>3.1</b> Technical characteristics .....	Pag. 6
<b>3.2</b> Dimensions .....	Pag. 6
<b>3.3</b> Unit's main components .....	Pag. 7
<b>4. Installation</b> .....	Pag. 8
<b>4.1</b> Mechanical installation .....	Pag. 8
<b>4.2</b> Safety chain .....	Pag. 8
<b>4.2</b> Adjusting unit's tilt .....	Pag. 9
<b>5. Powering up</b> .....	Pag. 10
<b>5.1</b> Operating voltage and frequency .....	Pag. 10
<b>5.2</b> Connection to mains power .....	Pag. 10
<b>6. Control signal connections</b> .....	Pag. 12
<b>6.1</b> Control signal connection by XLR5 plugs .....	Pag. 12
<b>6.2</b> Saving the DMX signal .....	Pag. 12
<b>7. Turning on the projector</b> .....	Pag. 13
<b>7.1</b> DMX addressing .....	Pag. 13
<b>8. Maintenance</b> .....	Pag. 13
<b>8.1</b> Periodic cleaning .....	Pag. 13
<b>8.2</b> Periodic control .....	Pag. 13
<b>9. F.A.Q. and answers</b> .....	Pag. 14

Congratulations on having purchased a **Coemar** product. You have assured yourself of a fixture of the highest quality, both in componentry and in the technology used. We renew our invitation to you to complete the service information on the previous page, to expedite any request for service information or spares (in case of problems encountered either during, or subsequent to, installation). This information will assist in providing prompt and accurate advice from your **Coemar** service centre. Following the instructions and procedures outlined in this manual will ensure the maximum efficiency of this product for years to come.

## 1. Packaging and transportation

### 1.1 Packaging

Open the packaging and make sure that no part of the equipment has suffered any damage during the transportation. In case of damage to the fixture, contact your carrier and your supplier immediately by telephone, fax or email, and inform them you will formally notify them in writing through registered letter.

#### Packing list

Make sure the packaging contains:

**1 PinSpot**

**1 Instruction manual**

### 1.2 Transportation

The **PinSpot** must be transported exclusively in its original packaging or in an appropriate flight case.

## 2. General information

### 2.1 Important Safety information

#### Fire prevention:



1. Never locate the fixture on any flammable surface.
2. Minimum distance from flammable materials: 0,5m.
3. Minimum distance from the closet illuminable surface: 0,5m.
4. Replace any blown or damaged fuse only with those of identical values. Refer to the schematic diagram if there is any doubt.
5. Connect the projector to mains power protected by a thermal magnetic circuit breaker.

#### Prevention from electric shock:



1. Presence of high voltage inside of the fixture. Insulate the projector from mains supply before opening or performing any function which involves touching the inside of the fixture, including lamp replacement.
2. For the connection to the mains, adhere strictly to the guidelines outlined in this manual.

3. The level of technology of **PinSpot** requires the use of specialised personnel for all service applications; refer all work to your authorised **Coemar** service centre.
4. A good earth connection is essential for the proper functioning of the projector. Never connect the fixture if there is no earth connection.
5. Mains cables must not come into contact with other cables.
6. Do not operate the projector with wet hands or in an area where water is present.
7. The fixture must never be located in an exposed position, or in areas of extreme humidity.

### Safety:



1. The projector must always be installed with bolts, clamps, or other fixing devices which are suitably rated to support the weight of the projector.
2. Always use a secondary safety fixing device with chain or steel wire of a suitable rating to sustain the weight of the unit in case of failure of the principal fixing point.
3. The external surfaces of the unit, at various points, may reach 60°C. Never handle the unit until at least 10 minutes have elapsed since the LED was turned off.
4. Never install the fixture in an enclosed area lacking sufficient air flow; the room temperature must not exceed 35°C.
5. The projector contains electronic and electrical components which must under no circumstances be in contact with water, oil or any other liquid. Failure to do so will compromise the proper functioning of the projector.

---

## 2.2 Warranty conditions

1. The fixture is under warranty for 36 months from the purchase date against factory defections.
2. Damage ought to unskillfulness, inappropriate use, or lack of suggested maintenance are excluded from the warranty.
3. Warranty expires when the projector is opened by unauthorized personnel.
4. Warranty doesn't include the replacement of the fixture.
5. Serial number and model of the fixture are necessary to retrieve informations and assistance from the dealer.

---

## 2.3 EC norms

The projector meets all fundamental applicable EC requirements.

# 3. Product specifications

## 3.1 Technical characteristics

<b>Power supply</b>	3 Vdc
<b>Maximum current</b>	700 mA @ 3 Vdc
<b>Power consumption</b>	3 W
<b>Color temperature</b>	Fixed white at 3.200 K or 5.600 K
<b>Weight</b>	0.4 kg - 0.88 lbs
<b>Maximum room temperature</b>	35°C
<b>IP rating</b>	IP 44

## 3.2 Dimensions

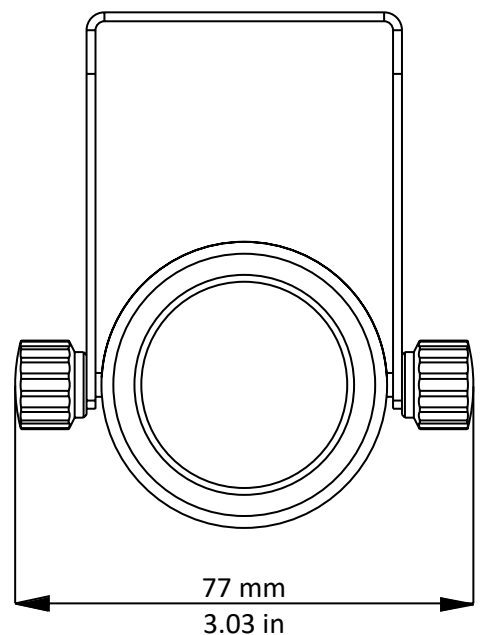
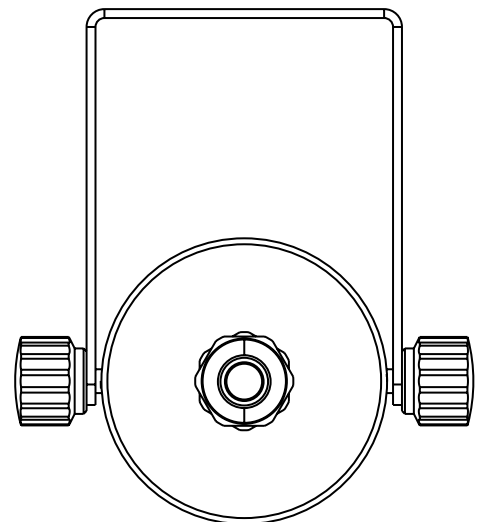
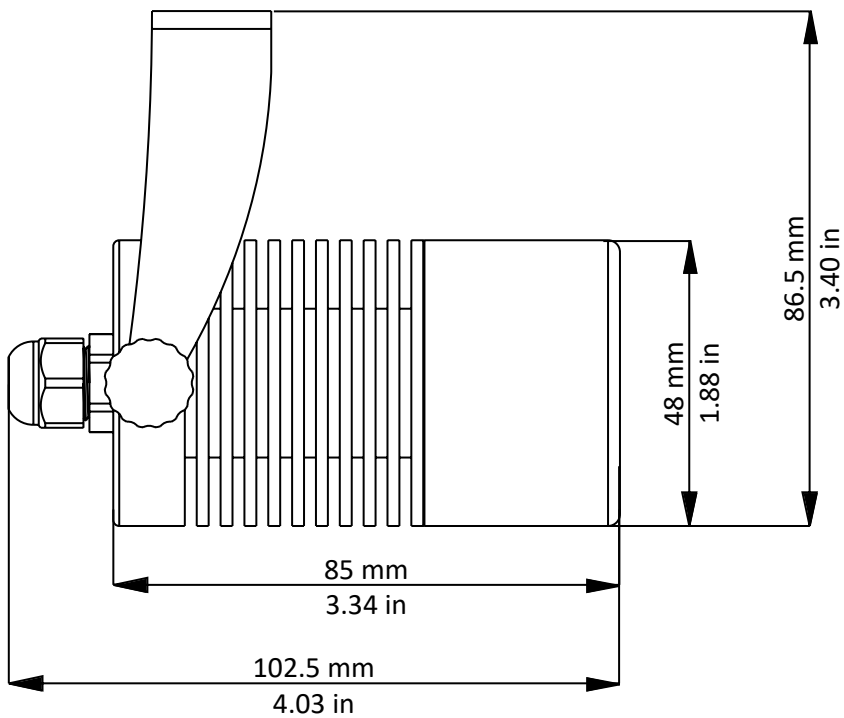

### 3.3 Unit's main components

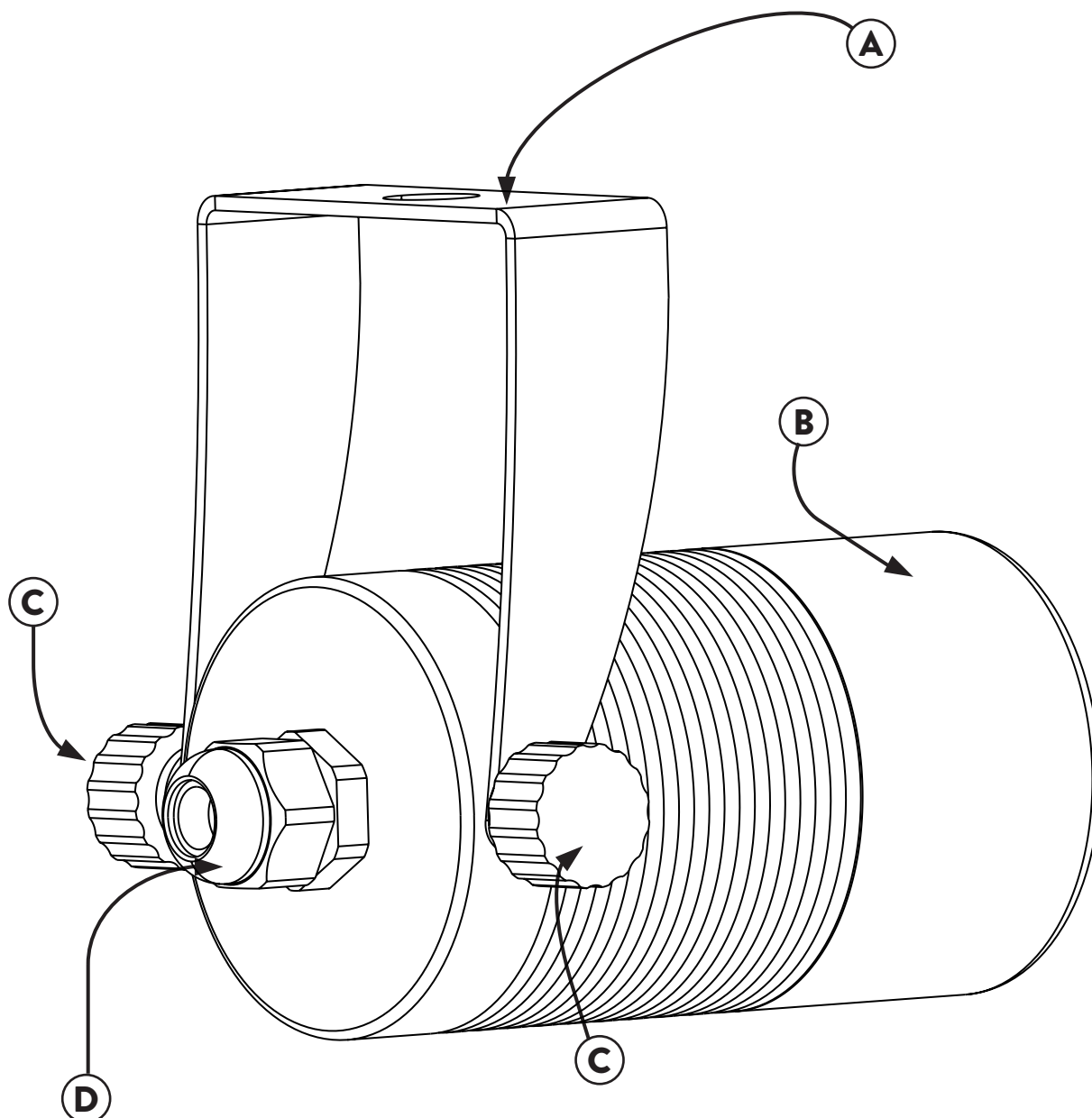

Components description	
<b>A</b>	Yoke
<b>B</b>	Main body
<b>C</b>	Yoke locking handle
<b>D</b>	Cable gland

# 4. Installation

## 4.1 Mechanical installation

**PinSpot** may be hung from an appropriate structure in any position or on tripod. If hanging the fixture from a lighting truss or similar, we recommend the use of an appropriate clamp “A”, as shown in the following diagram.

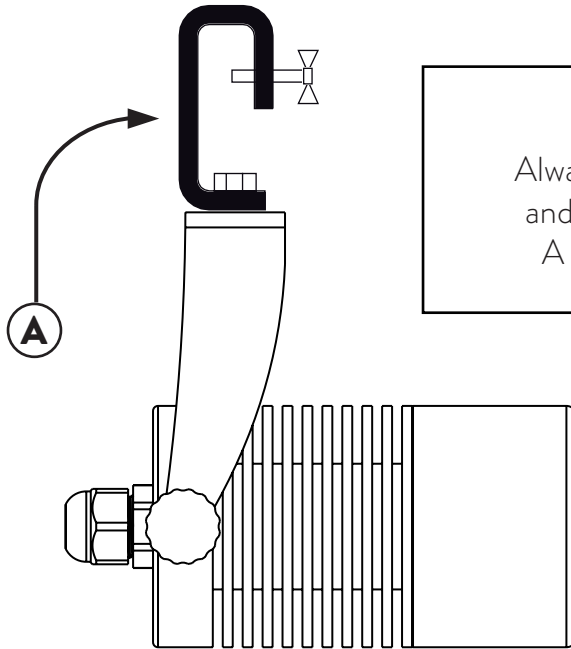

### Warning!!

Always ensure that your support structure and fixing (bolts, clamps, etc...) are rated A to support the weight of the fixture.

## 4.2 Safety chain

When hanging **PinSpot** it is recommended to use a safety chain, as required by current legislation. The safety chain must pass through the yoke of the unit and then attached to the structure. If using steel cables and chains not **Coemar**'s production, make sure they are suitable to support the weight of the unit according to normative UL/ETL (required: the weight of 6 complete devices for at least one hour).

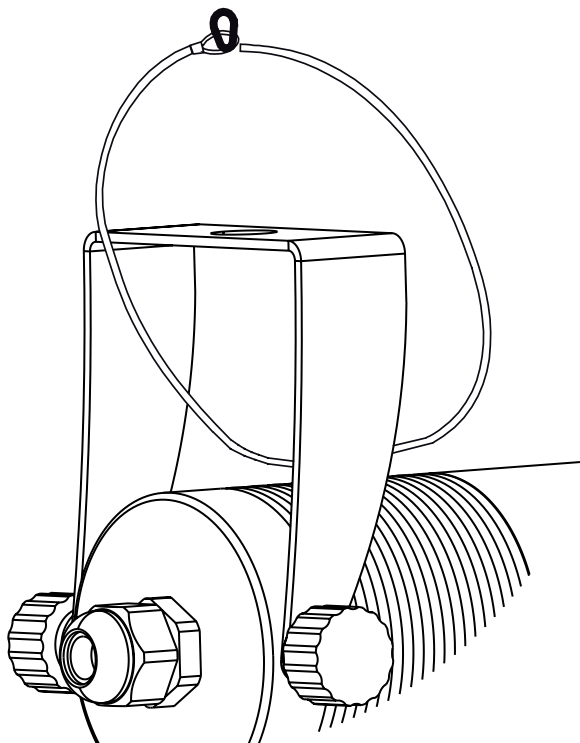



---

### 4.3 Adjusting unit's tilt

In order to adjust the tilt of the unit simply loose the side handle adjust the tilt and lock the yoke by tightening the handle again.

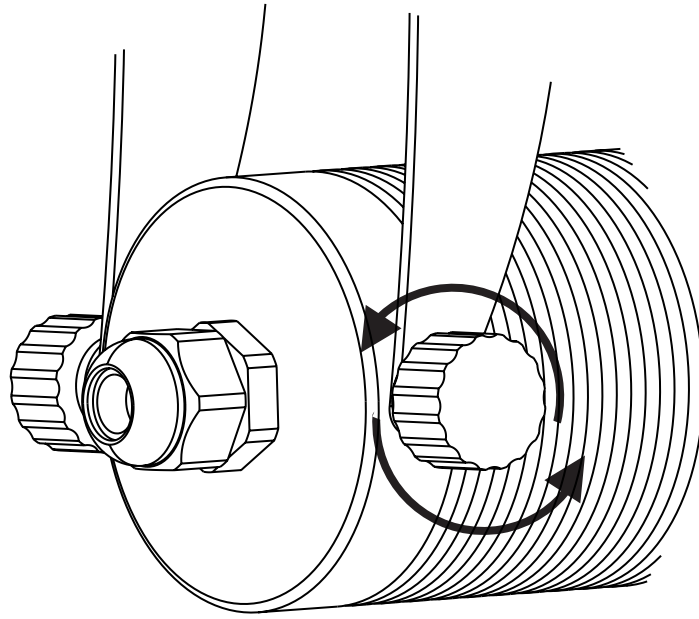

# 5. Powering up

## 5.1 Operating voltage and frequency

The unit may operate with a voltage of 48 Vdc. It is not needed to effect any setup procedures: **PinSpot** will automatically adjust its operation to suit any frequency or voltage within this range.

## 5.2 Connection to mains power

### Mains cable characteristics

The mains cable provided is thermally resistant, complying to the most recent International standards.

**Note:** in case of cable replacement, similar cable with comparable thermal resistant qualities must be used exclusively (cable PVC extruded AWM style 24364 80°).

### Connection to mains power

To connect **PinSpot** to the main power follow the instruction given below.

- Be in possession of a power supply **Switching** and a **RegoBox** (code AC10005E012).
- Connect the **RegoBox** to the Switching and then connect the Switching to the power plug;
- Connect the **PinSpot** to the **RegoBox** (it is possible to connect up to five PinSpot lines per controller, see page 11);
- Close the **PinSpot** line with the stopper plug supplied (see the image below).

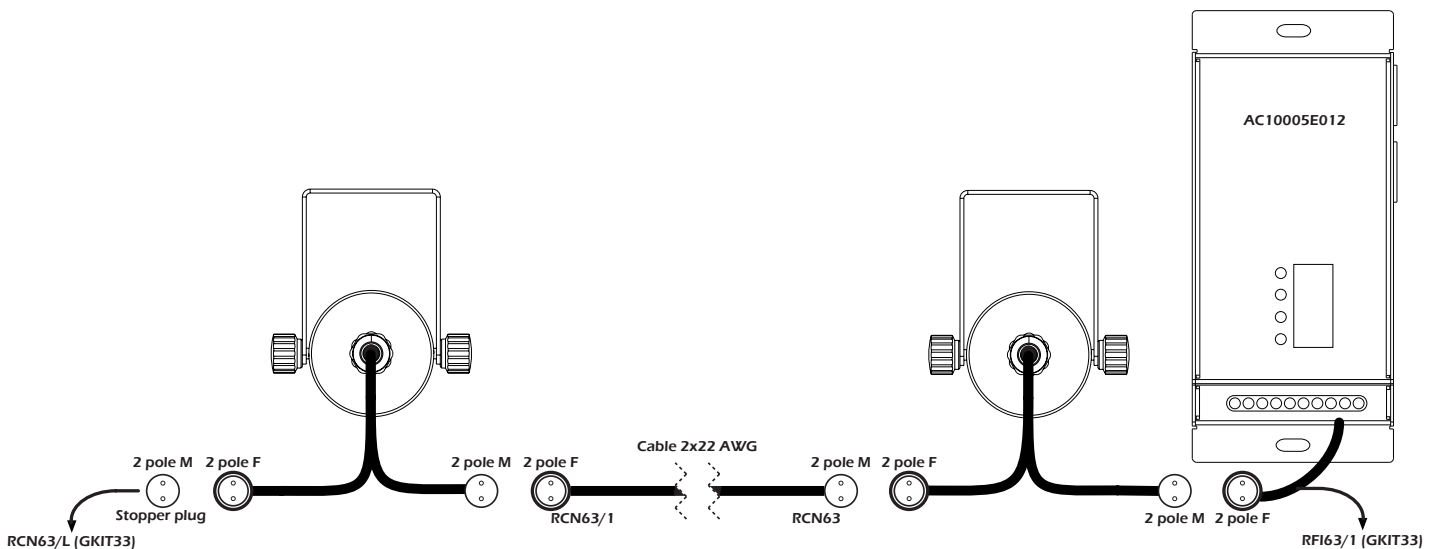

### Warning!!

The use of a thermal/magnetic circuit breaker is recommended. Strict adherence to regulatory norms is strongly recommended.

Prior to connecting the device to mains power, ensure that the mains characteristics are within the recommended range for the use of **PinSpot**.

All cabling and connections should be carried out by a suitably qualified personnel.

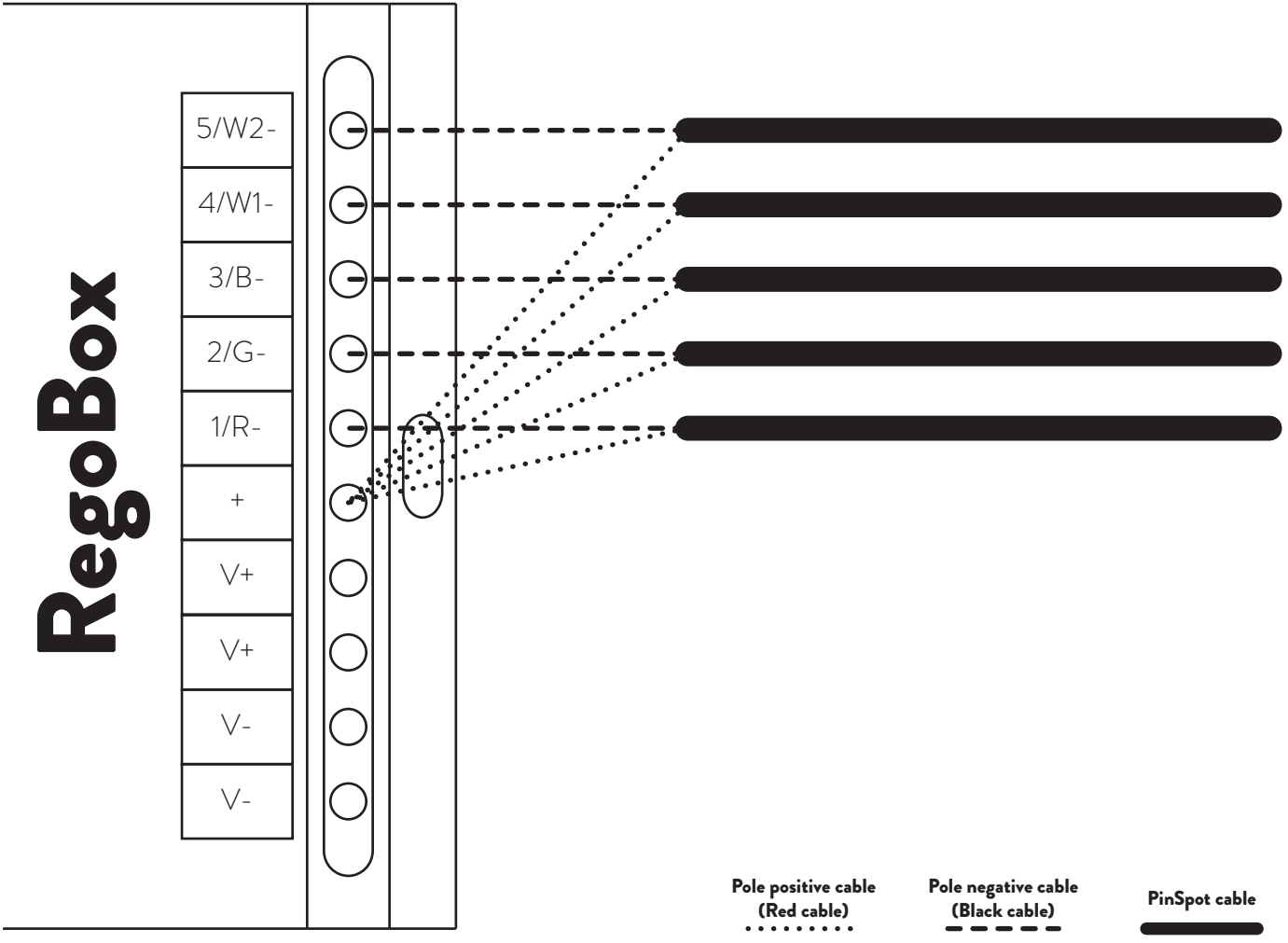

The controller can control up to 10 **PinSpot** per channel

# 6. Control signal connections

## 6.1 Control signal connection by XLR5 plugs

The digital control signal is transmitted to the projector via two pole cable screened according to the International standards for the transmission of DMX 512 data. The connection must be serial, by connecting the single input cable from the **PinSpot** in the **RegoBox**'s output "A", which will be connected to a console. The connectors provided with the **PinSpot** are IP rating, ensuring protection against dust and water.

In order to maintain this gradation they may only be connected to other connectors with IP rating.

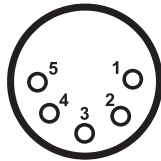

- Pin 1 = Mass (GND)**
- Pin 2 = Data -**
- Pin 3 = Data +**
- Pin 4 = not connected**
- Pin 5 = not connected**

### Warning!

Make sure that screening and conductors are not in contact one another or with the metal housing of the connector. Pin#1 and housing must never be connected to the power supply unit.

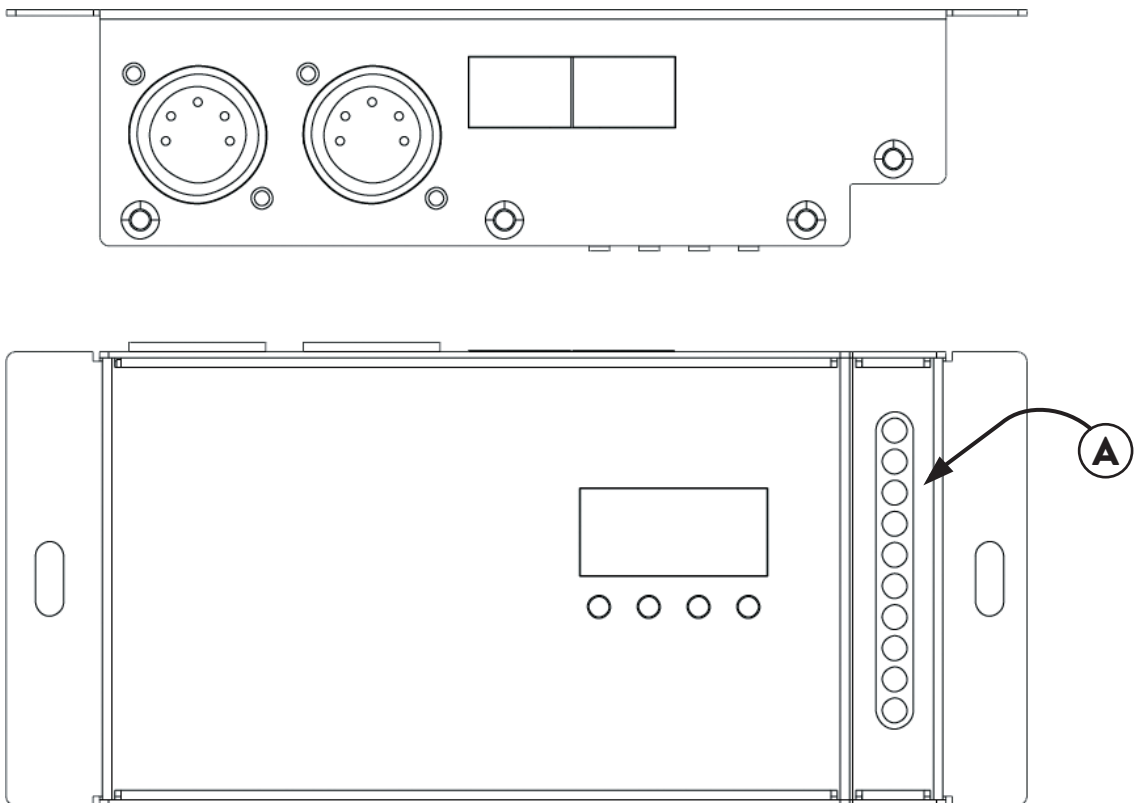

## 6.2 Saving the DMX signal

If you want to use the projector without a console is possible to memorize a DMX address removing the DMX signal when the projector is on, to keep the current values at the time when the signal is removed

## 7. Turning on the projector

After having followed the preceding steps described, proceed with the power supply and turn on the projector connecting it to the mains power.

### 7.1 DMX addressing

The assignment of the DMX channel is settable directly by the **RegoBox**.

## 8. Maintenance

### 8.1 Periodic cleaning

#### Lenses

Even a fine layer of dust can reduce the luminous output and alter the compactness of the beam. Regularly clean all filters and lenses using a soft cotton cloth, dampened with a specialist lens cleaning solution.

#### Cleaning of the unit

Use a soft brush or a common vacuum cleaner or a source of compressed air for removing dust. For the cleaning of the housing use a soft cloth and a non-aggressive cleaner. Check that the internal fans and heat exchanger must be perfectly clean.

### 8.2 Periodic controls

#### Mechanical components

Check the correct working of the mechanical parts and, if needed, replace them. Make sure the projector is not mechanically damaged. If necessary, replace the worn parts.

#### Electrical components

Check all electrical connections, in particular for correct grounding and correct attachment of all extractable connectors. Press the connectors if necessary and reposition as before.

## 9. F.A.Q. and answers

The following list shows common issues that may be simply solved. If issues persist, the unit must be repaired by qualified personnel or just contact your **Coemar** service near you.

Question	Possible solution
<b>PinSpot</b> does not emit light	<b>Projector not powered on:</b> <ul style="list-style-type: none"><li>• Make sure the power cord is plugged in or test the input voltage;</li><li>• Make sure that the stopper plug is screwed properly at the end of the chain</li></ul>
<b>PinSpot</b> does not answer to DMX signal	<b>DMX signal may not reach RegoBox:</b> <ul style="list-style-type: none"><li>• Inspect the cable connection, correct poor connections or inefficient repair or replace damaged cables;</li></ul>





**Information on disposal of the equipment**

The equipment at the end of its useful life must be disposed of at an appropriate recycling center for waste electrical and electronic equipment. The treatment and disposal of environmentally friendly, helps prevent potential negative environmental and health and promote the reuse and / or recycling of materials making up the equipment. Illegal disposal by the user includes the application of administrative sanctions provided by law.





**Coemar Lighting s.r.l.**

Via Carpenedolo 90  
46043 Castiglione delle Stiviere, Mantova, Italia  
tel. +39 0376/1514412 - fax +39 0376/1514380  
[info@coemar.com](mailto:info@coemar.com)

**Coemar** reserves the right to change specifications without prior notice