



# LEDko EXT M

Last update:  
17/11/2023



## LEDko EXT M

### Introducing

● We took our flagship product and made it smaller. Much smaller. We are proud to introduce you to the new Coemar product family, LEDko EXT M.

Thanks to LEDko EXT M we can expand our offer and make available all the quality we offer with LEDko EXT, in a much smaller body.

High power is not always necessary and this is why LEDko EXT M was born. Anyone who needs a profiler with an incredible light emitted/power ratio must have our brand new LEDko EXT M. We have thought of everything, from optics to mounting options, to communication protocols, to ensure that anyone can find the perfect product for their needs.

### Key Features

- IP65
● LED Profile Spot IP65 for permanent Outdoor installation

---

- 58 W White COB LED (T/D version)  
● 58 W COB LED (VW version)

---

- CRI
● CRI 80, CRI 90 or CRI > 95 (T/D version)  
● CRI > 98, TLCI 98 @ 3.200 K, CRI 95, TLCI 97 @ 5.600 K (VW version)

---

- CCT
● CCT available: 2.700 K, 3.000 K, 3.500 K, 4.000 K, 5.000 K (T/D version)  
● CCT: Tunable white from 2.800 K → 5.600 K (VW version)

---

- High lumen flux and flat field

---

- Profile Zoom 15° - 30° or 19°, 26°, 36°, 50° Lens Tube  
● Proportional Zoom with HD optics ensure a clear and vivid images projection

---

- Internal four blade framing system

---

- AL
● Extruded aluminium

---

- Custom color on request (optional)

---

- European Conformity certification

General	
● LED Source	55 W White COB LED (T/D), 55 W COB LED (VW version)
● CCT Range	●●●●● 2.700 K, 3.000 K, 3.500 K, 4.000 K, 5.000 K (T/D version) ●●●●● Proportional control from 2.800 K to 5.600 K (VW version)
● Color Rendition Average	CRI> 98, TLCI 98 @ 3.200 K, CRI 95, TLCI 97 @ 5.600 K
● Light efficiency	Zoom min ( 15-35°): 811.48 lm Zoom max ( 15-35°): 1228.77 lm
● Dimming	Smooth 100% to 0% (DMX version)
● Lens	Profile Zoom 15°-30° or 19°, 26°, 36°, 50° Lens Tube
● Framing System	Four blade framing system, each shutter blade is adjustable for radial position and angle
● Camera flicker control/Hz range	Yes, from 600 to 20.000 Hz (DMX version)
● Calibrated Cob	Yes
● L80 Rating (hours to 80% output)	50.000 Hours
● Pattern Projection	Yes
● Pattern Size	Gobo outside diameter = 26 mm / 1.02 in Max image diameter = 22 mm / 0.86 in Max Gobo thickness = 2 mm / 0.08 in (glass gobo)
Electrical	
● Voltage Input	85-264 V, 47/63 Hz (on request available in other voltage range), auto-sensing
● Power Consumption	58 W Typical - 0.28 A @ 230V, 0.56A @ 115 V - cos 0.9
● Power Connection	0.5 mt. (19.69 in) Integrated cable without power plug
● Data Connection	In and Out DMX 5 pin locking XLR connectors (DMX version)
Thermal	
● Ambient Operating Temperature	-25°C - +40°C (-13°F - 104°F)
● Ambient Storage Temperature	-30°C - +80°C (-22°F - 176°F)
● Active Electronic Thermal	Active electronic thermal management operation
● Cooling	Noiseless, fan-free convection cooling
Control	
● Protocols	On/Off, DMX-512, RDM (Remote Device Management), Wireless (optional By LumenRadio)
● RDM configuration	Yes (only DMX version)
● DMX Channels	5 / 1 (T/D version) 5 / 2 / 1 (VW version)
Physical	
● Mounting options	Yoke
● Materials	Extruded aluminium
● Weight	Body: 2.8 Kg / 6.17 lbs - Power supply box: 0.96 Kg / 2.12 lbs
● Length	351 mm / 13.82 in
● Height	175 mm / 6.89 in
● Width	132 mm / 5.19 in
● IP Rating	IP65
● Color options	Black (standard), custom color on request (optional)
General accessories	
BC074A008	Metal Gobo Holder
BC074A009	Glass Gobo Holder
BC074A000	Lens Tube 19°
BC074A001	Lens Tube 26°
BC074A002	Lens Tube 36°
BC074A003	Lens Tube 50°
BC074A0200	Profile Zoom 15°-30°



LEDko EXT M optical group

DMX Charts - T / D version

**5 Channels**

- 01 → Master Dimmer
- 02 → Spare Channel
- 03 → Dimmer Fine
- 04 → Strobe
- 05 → Special Functions

**1 Channel**

- 01 → Master Dimmer

DMX Charts - VariWhite version

**5 Channels**

- 01 → Master Dimmer
- 02 → Dimmer Fine
- 03 → White tone
- 04 → Strobe Effect
- 05 → Special Functions

**2 Channels**

- 01 → Master Dimmer
- 02 → White Tone

**1 Channels**

- 01 → Master Dimmer

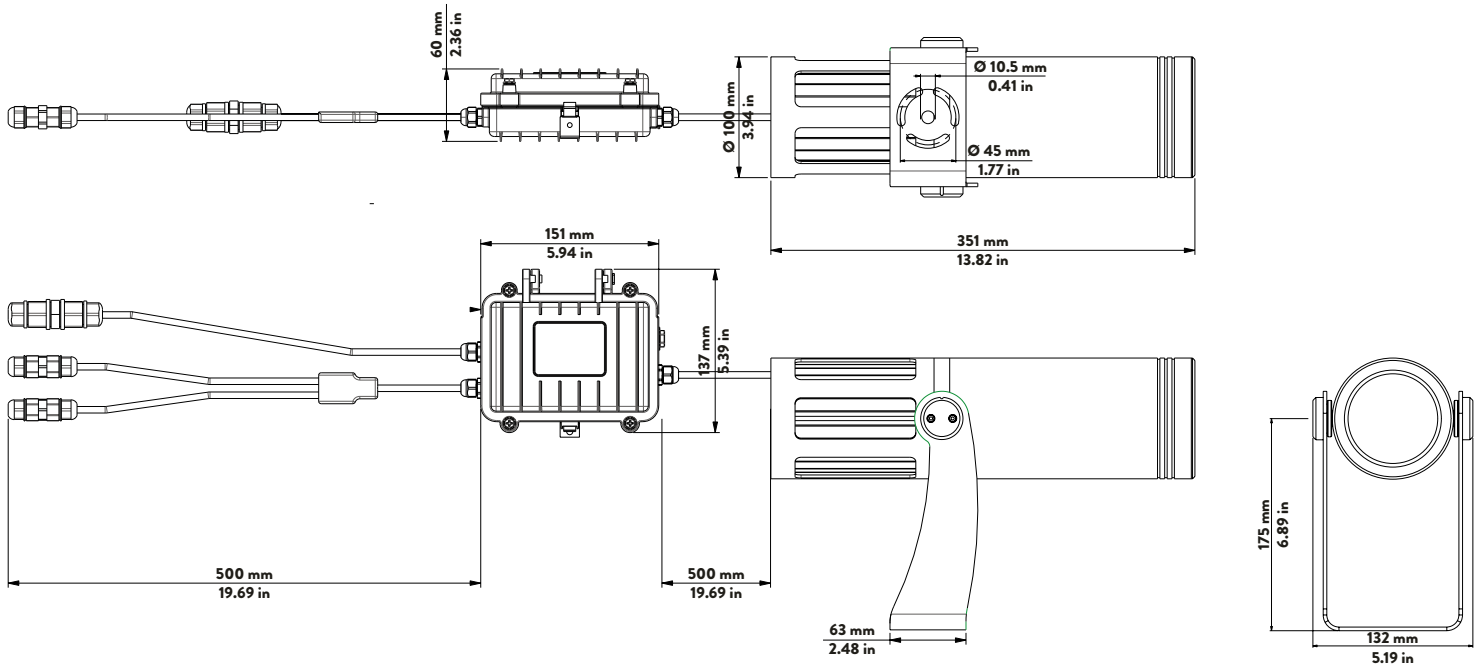

\*Power Box



Architectural Outdoor - Six Senses Residences Crans-Montana, Switzerland

Product	LEDko EXT M VW
CCT	2.800K → 5.600K
CRI	>95
Version	Zoom 15-30°
Light Designer	Martin V. Cook
Installation	Établissements Techniques Fragnière SA

**LEDko M Profile Tungsten (3.000 K) - CRI 80**Optic: **Lens Tube Profile 19°**

Distance (m)	1	2	3	4	5	6	7	8	9	10
<b>lux</b> <b>3.000 K</b>	18423	4606	2047	1151	737	512	376	288	227	184
<b>Diameter Ø (m)</b>	0.32	0.63	0.95	1.27	1.58	1.90	2.22	2.53	2.85	3.17

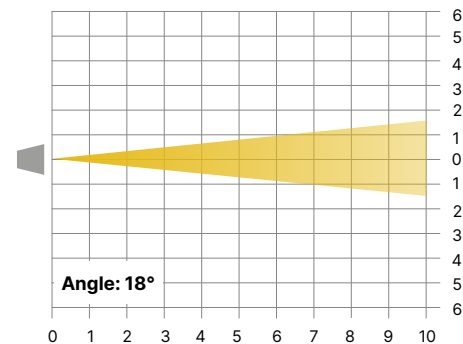
Optic: **Lens Tube Profile 26°**

Distance (m)	1	2	3	4	5	6	7	8	9	10
<b>lux</b> <b>3.000 K</b>	9576	2394	1064	599	383	266	195	150	118	96
<b>Diameter Ø (m)</b>	0.46	0.92	1.39	1.85	2.31	2.77	3.23	3.96	4.16	4.62

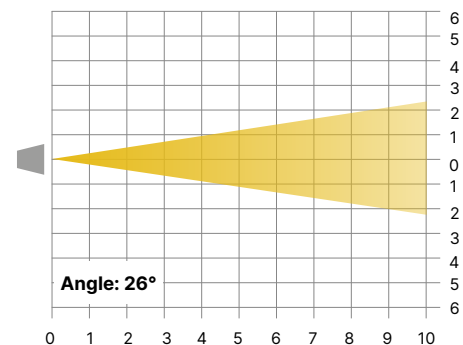
Optic: **Lens Tube Profile 36°**

Distance (m)	1	2	3	4	5	6	7	8	9	10
<b>lux</b> <b>3.000 K</b>	6804	1701	756	425	272	189	139	106	84	68
<b>Diameter Ø (m)</b>	0.55	1.11	1.66	2.22	2.77	3.33	3.88	4.44	4.99	5.55

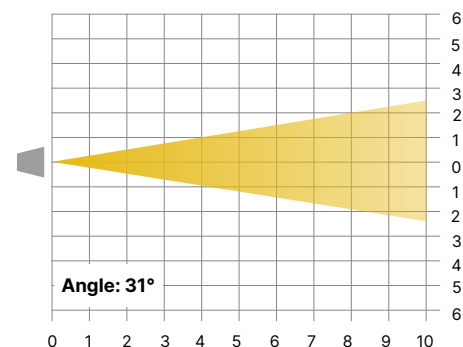



**LEDko M Profile Tungsten (3.000 K) - CRI 80**Optic: **Lens Tube Profile 50°**

Distance (m)	1	2	3	4	5	6	7	8	9	10
<b>lux</b> <b>3.000 K</b>	3240	810	360	203	130	90	66	51	40	32
<b>Diameter Ø (m)</b>	0.91	1.82	2.73	3.65	4.56	5.47	6.38	7.29	8.20	9.11

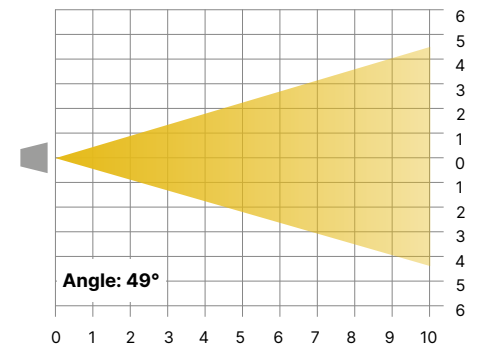
Optic: **Profile Zoom 15° - 30° - SPOT**

Distance (m)	1	2	3	4	5	6	7	8	9	10
<b>lux</b> <b>3.000 K</b>	19440	4860	2160	1215	778	540	397	304	240	194
<b>Diameter Ø (m)</b>	0.25	0.49	0.74	0.98	1.23	1.47	1.72	1.96	2.21	2.46

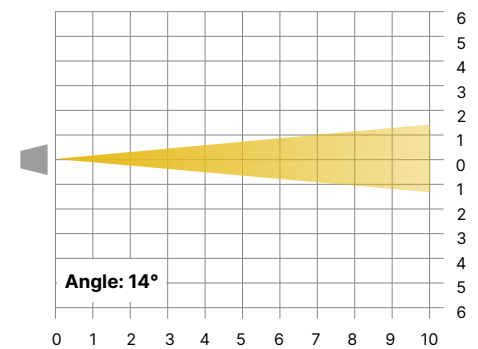
Optic: **Profile Zoom 15° - 30° - FLOOD**

Distance (m)	1	2	3	4	5	6	7	8	9	10
<b>lux</b> <b>3.000 K</b>	9873	2468	1097	617	395	274	201	154	122	99
<b>Diameter Ø (m)</b>	0.48	0.96	1.44	1.92	2.40	2.88	3.36	3.84	4.32	4.80

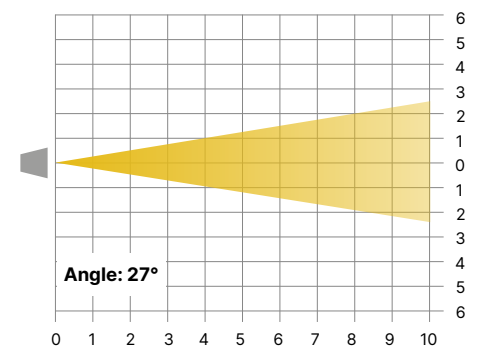



**LEDko M Profile Daylight (5.000 K) - CRI 80**Optic: **Lens Tube Profile 19°**

Distance (m)	1	2	3	4	5	6	7	8	9	10
<b>lux</b> <b>5.000 K</b>	20.268	5.067	2.252	1.267	811	563	414	317	250	203
<b>Diameter Ø (m)</b>	0.32	0.63	0.95	1.27	1.58	1.90	2.22	2.53	2.85	3.17

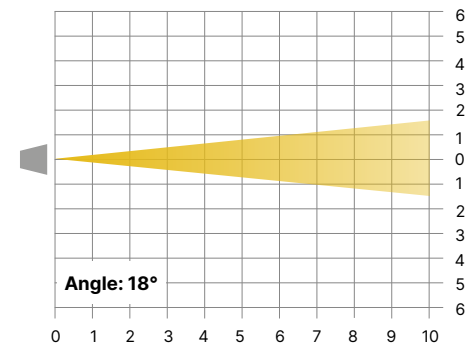
Optic: **Lens Tube Profile 26°**

Distance (m)	1	2	3	4	5	6	7	8	9	10
<b>lux</b> <b>5.000 K</b>	10.530	2.633	1.170	658	421	293	215	165	130	105
<b>Diameter Ø (m)</b>	0.46	0.92	1.39	1.85	2.31	2.77	3.23	3.96	4.16	4.62

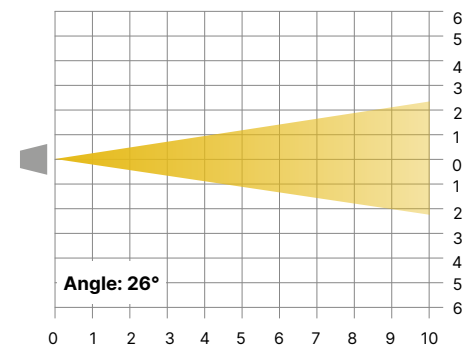
Optic: **Lens Tube Profile 36°**

Distance (m)	1	2	3	4	5	6	7	8	9	10
<b>lux</b> <b>5.000 K</b>	7.488	1.872	832	468	300	208	153	117	92	75
<b>Diameter Ø (m)</b>	0.55	1.11	1.66	2.22	2.77	3.33	3.88	4.44	4.99	5.55

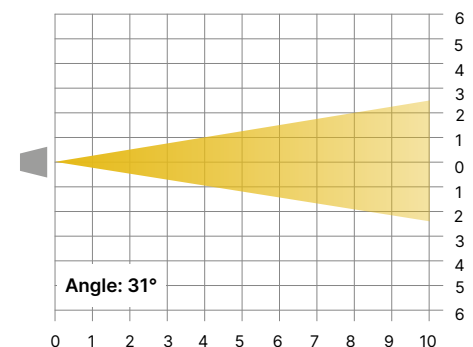

**LEDko M Profile Daylight (5.000 K) - CRI 80**Optic: **Lens Tube Profile 50°**

Distance (m)	1	2	3	4	5	6	7	8	9	10
<b>lux</b> <b>5.000 K</b>	3.356	891	396	223	143	99	73	56	44	36
<b>Diameter Ø (m)</b>	0.91	1.82	2.73	3.65	4.56	5.47	6.38	7.29	8.20	9.11

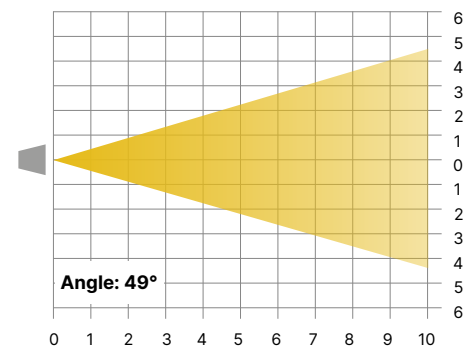
Optic: **Profile Zoom 15° - 30° - SPOT**

Distance (m)	1	2	3	4	5	6	7	8	9	10
<b>lux</b> <b>5.000 K</b>	21.384	5.346	2.376	1.337	855	594	436	334	264	214
<b>Diameter Ø (m)</b>	0.25	0.49	0.74	0.98	1.23	1.47	1.72	1.96	2.21	2.46

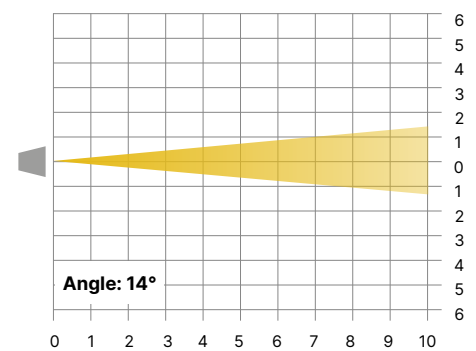
Optic: **Profile Zoom 15° - 30° - FLOOD**

Distance (m)	1	2	3	4	5	6	7	8	9	10
<b>lux</b> <b>5.000 K</b>	10.863	2.716	1.207	679	435	302	222	170	134	109
<b>Diameter Ø (m)</b>	0.48	0.96	1.44	1.92	2.40	2.88	3.36	3.84	4.32	4.80

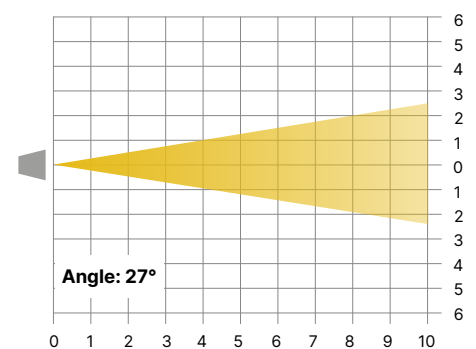

## LEDko M Profile VariWhite - CRI &gt; 95

Optic: Lens Tube Profile 19°

Distance (m)	1	2	3	4	5	6	7	8	9	10	
lux	<b>3.200 K</b>	13545	3386	1505	847	542	376	276	212	167	135
	<b>5.600 K</b>	17280	4320	1920	1080	691	480	353	270	213	173
Diameter Ø (m)	0.32	0.63	0.95	1.27	1.58	1.90	2.22	2.53	2.85	3.17	
<b>3.200 K</b>	CRI 97.2		TLCI 98								
<b>5.600 K</b>	CRI 95.4		TLCI 97.3								

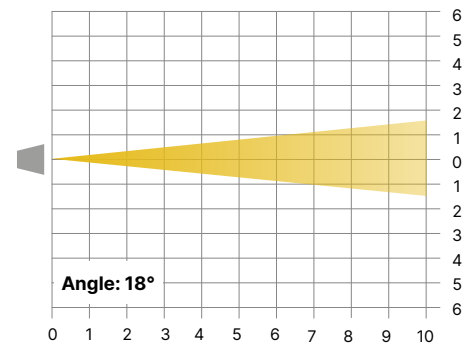

Optic: Lens Tube Profile 26°

Distance (m)	1	2	3	4	5	6	7	8	9	10	
lux	<b>3.200 K</b>	6876	1719	764	430	275	191	140	107	85	69
	<b>5.600 K</b>	8802	2201	978	550	352	245	180	138	109	88
Diameter Ø (m)	0.46	0.92	1.39	1.85	2.31	2.77	3.23	3.69	4.16	4.62	
<b>3.200 K</b>	CRI 97.2		TLCI 98								
<b>5.600 K</b>	CRI 95.5		TLCI 97.4								

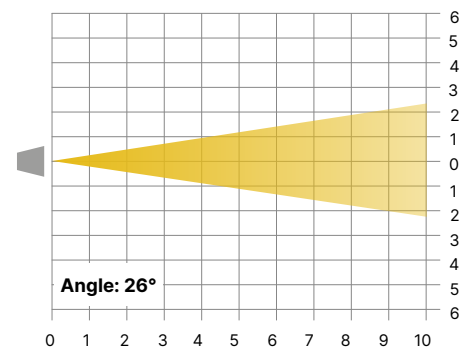

Optic: Lens Tube Profile 36°

Distance (m)	1	2	3	4	5	6	7	8	9	10	
lux	<b>3.200 K</b>	4599	1150	511	287	184	128	94	72	57	46
	<b>5.600 K</b>	5949	1487	661	372	238	165	121	93	73	59
Diameter Ø (m)	0.55	1.11	1.66	2.22	2.77	3.33	3.88	4.44	4.99	5.55	
<b>3.200 K</b>	CRI 97.3		TLCI 98								
<b>5.600 K</b>	CRI 95.2		TLCI 97.2								

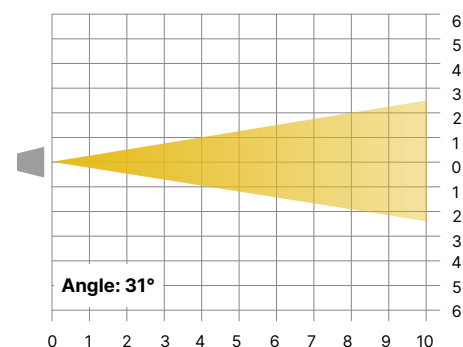

**LEDko M Profile VariWhite - CRI > 95**Optic: **Lens Tube Profile 50°**

Distance (m)	1	2	3	4	5	6	7	8	9	10	
lux	<b>3.200 K</b>	2187	547	243	137	87	61	45	34	27	22
	<b>5.600 K</b>	3159	790	351	197	126	88	64	49	39	32
Diameter Ø (m)	0.91	1.82	2.73	3.65	4.56	5.47	6.38	7.29	8.20	9.11	
<b>3.200 K</b>	CRI 97.2		TLCI 98								
<b>5.600 K</b>	CRI 95		TLCI 97.3								

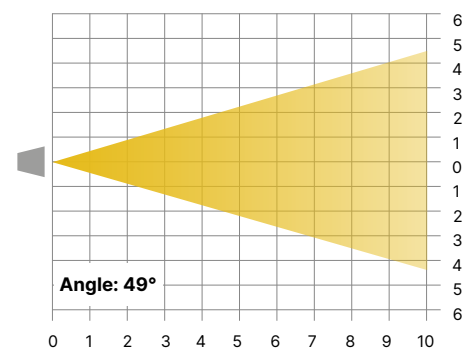
Optic: **Profile Zoom 15° - 30° - SPOT**

Distance (m)	1	2	3	4	5	6	7	8	9	10	
lux	<b>3.200 K</b>	15633	3908	1737	977	625	434	319	244	193	156
	<b>5.600 K</b>	22302	5576	2478	1394	892	620	455	348	275	223
Diameter Ø (m)	0.25	0.49	0.74	0.98	1.23	1.47	1.72	1.96	2.21	2.46	
<b>3.200 K</b>	CRI 97.4		TLCI 97.9								
<b>5.600 K</b>	CRI 93.6		TLCI 96.6								

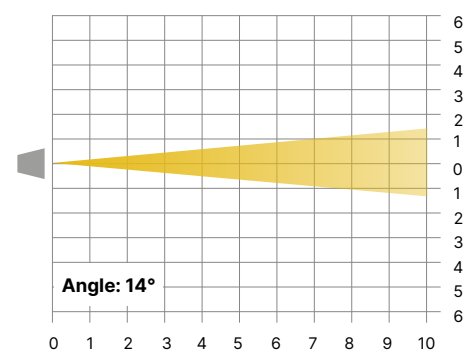
Optic: **Profile Zoom 15° - 30° - FLOOD**

Distance (m)	1	2	3	4	5	6	7	8	9	10	
lux	<b>3.200 K</b>	6543	1636	727	409	262	182	134	102	81	65
	<b>5.600 K</b>	8424	2106	936	527	337	234	712	132	104	84
Diameter Ø (m)	0.48	0.96	1.44	1.92	2.40	2.88	3.36	3.84	4.32	4.80	
<b>3.200 K</b>	CRI 97.3		TLCI 97.9								
<b>5.600 K</b>	CRI 95.2		TLCI 96.9								

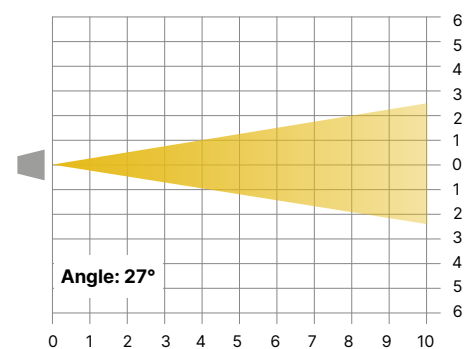

# REPORT OF THE TM30 TEST

**Rf 94,4**  
 Fidelity index Rf

**Rg 100,7**  
 Gammut index Rg

## ■ Spectrum

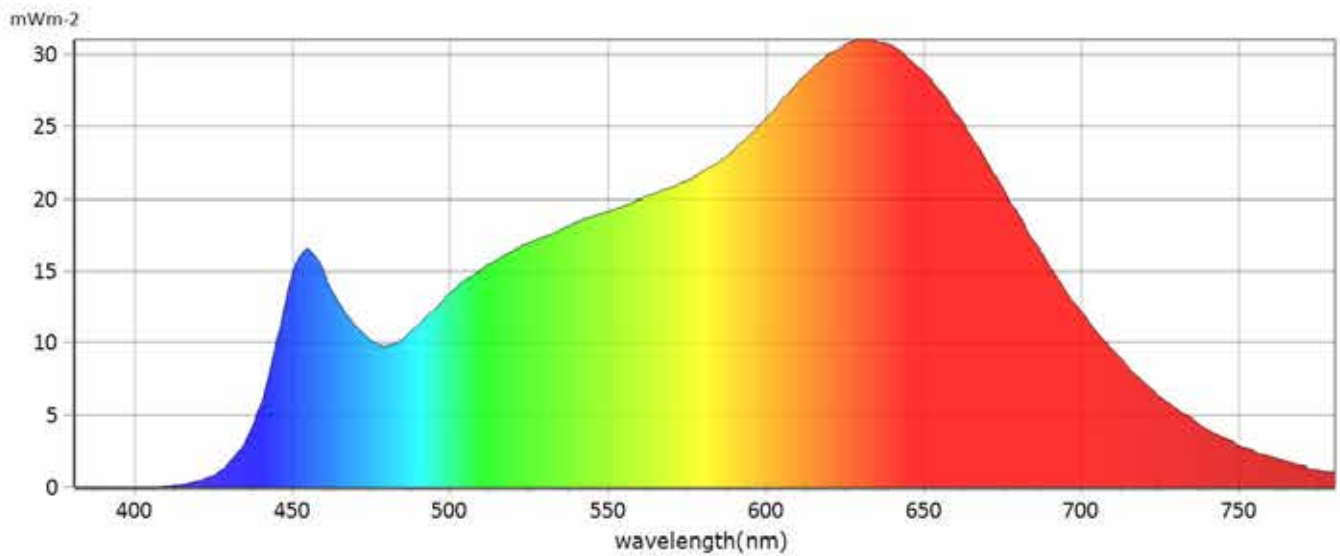

## ■ General Color Rendition

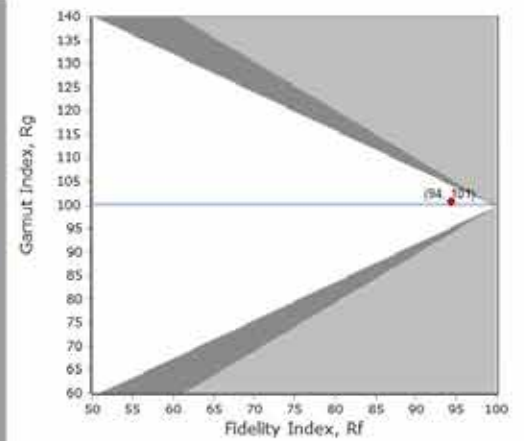
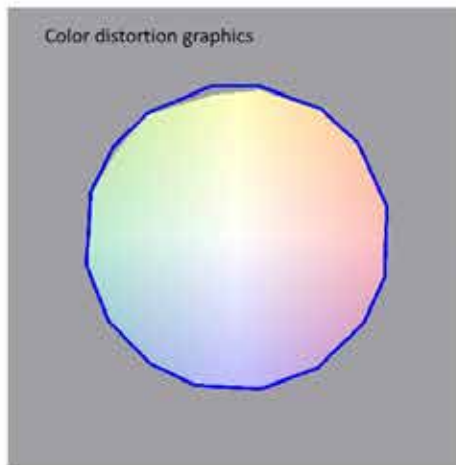
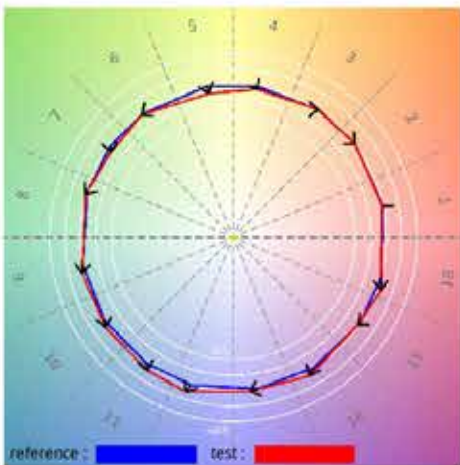

# REPORT OF THE TM30 TEST

**Rf 94,4**

Fidelity index Rf

**Rg 100,7**

Gammut index Rg

## Color Rendition by Hue

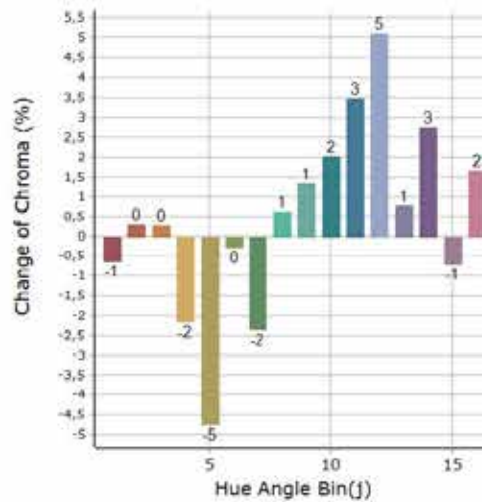
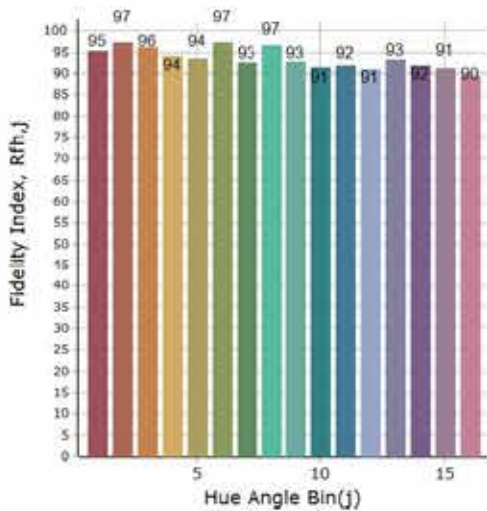

Hue Bin	Rf	Graphic shifts (%)	
		Chroma	Hue
1	95,3	-0,6%	0,9%
2	97,2	0,3%	-0,2%
3	96,0	0,3%	-0,4%
4	94,2	-2,2%	-2,2%
5	93,5	-4,7%	-0,7%
6	97,3	-0,3%	1,2%
7	92,5	-2,3%	3,4%
8	96,5	0,6%	1,9%
9	92,7	1,3%	5,1%
10	91,5	2,0%	4,2%
11	92,0	3,5%	3,6%
12	90,9	5,1%	-1,9%
13	93,2	0,8%	-4,5%
14	91,8	2,7%	-4,9%
15	91,2	-0,7%	-1,8%
16	89,6	1,7%	-8,3%

## Color Fidelity by Sample

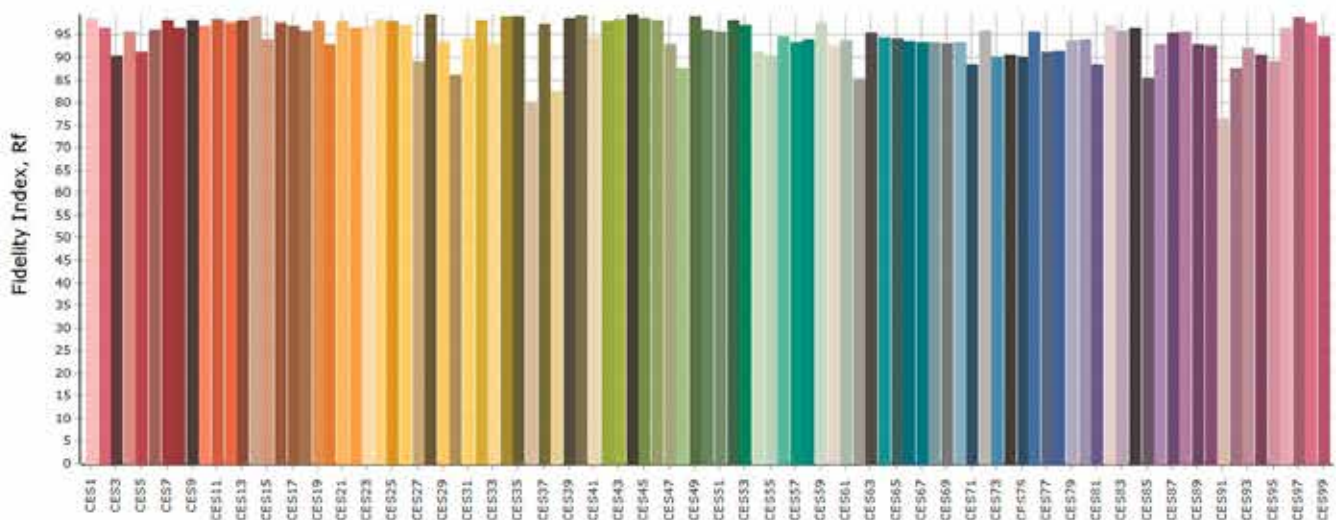

# REPORT OF THE SPECTRUM TEST

## BASE

CCT	: 3164 K
x	: 0,4229
y	: 0,3936
LambdaD	: 583 nm
LambdaP	: 631 nm

## Spectrum

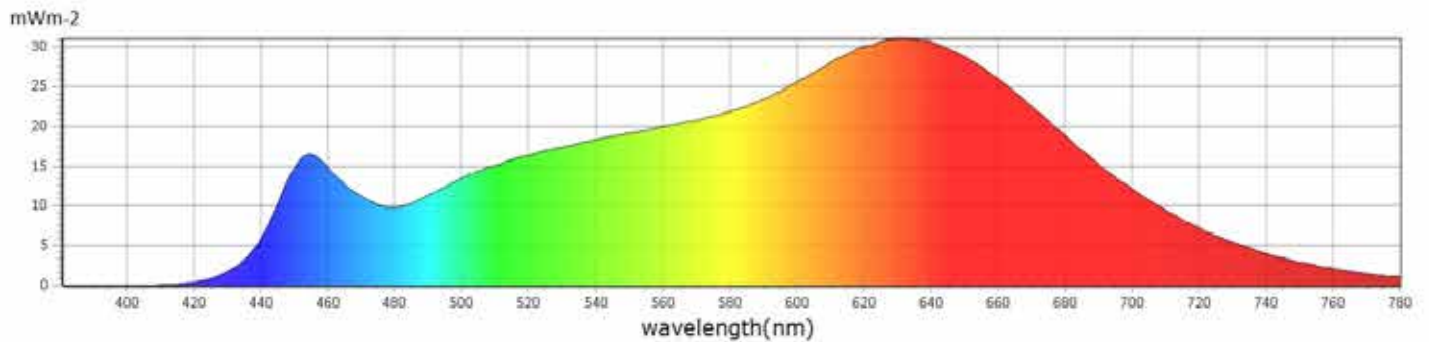

## CIE1931

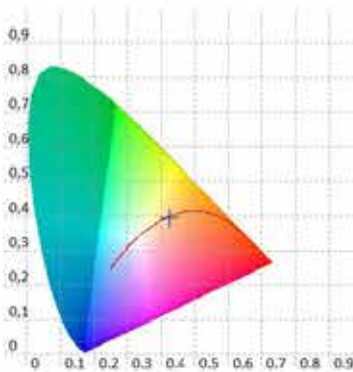

## CIE1976

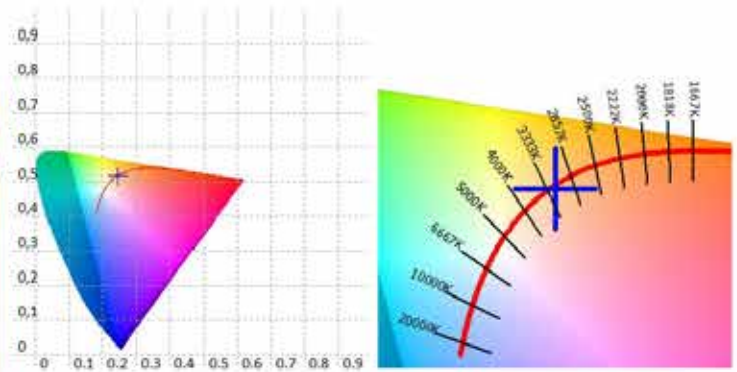

## Features

CCT : 3164 K	x10 : 0,4270	delta-x : -0,0028	LambdaD : 583 nm	PPFD : 25,42 $\mu\text{mol}\cdot\text{m}^{-2}\cdot\text{s}^{-1}$	S/P : 1,58	R3 : 99,4	R10 : 95,9
LUX : 1505 lx	y10 : 0,3942	delta-y : -0,0063	LambdaP : 631 nm	PFD : 27,73 $\mu\text{mol}\cdot\text{m}^{-2}\cdot\text{s}^{-1}$	IRR : 5,586	R4 : 98,0	R11 : 95,3
I-Time : 8400 us	u'10 : 0,2484	delta-u' : 0,0008	Purity : 45,07%	PFD-B : 3,044 $\mu\text{mol}\cdot\text{m}^{-2}\cdot\text{s}^{-1}$	CQS : 96,2	R5 : 97,0	R12 : 86,0
x : 0,4229	v'10 : 0,5159	delta-v' : -0,0030	fc : 139,9	PFD-G : 8,963 $\mu\text{mol}\cdot\text{m}^{-2}\cdot\text{s}^{-1}$	CRI : 97,2	R6 : 94,6	R13 : 96,6
y : 0,3936	X : 1617,10	Duv : -0,0021	Rf : 94,4	PFD-R : 13,41 $\mu\text{mol}\cdot\text{m}^{-2}\cdot\text{s}^{-1}$	TLCI : 98,0	R7 : 96,8	R14 : 98,7
u' : 0,2459	Y : 1505,23	MEL : 954,9 lx	Rg : 100,7	PFD-UV : 0,0000 $\mu\text{mol}\cdot\text{m}^{-2}\cdot\text{s}^{-1}$	R1 : 97,1	R8 : 97,2	R15 : 97,9
v' : 0,5151	Z : 701,63	LambdaPV : 31,03	GAI : 65,4	PFD-FR : 2,309 $\mu\text{mol}\cdot\text{m}^{-2}\cdot\text{s}^{-1}$	R2 : 97,5	R9 : 95,9	



# REPORT DEL TEST DI SPETTRO

## BASE

CCT : 3164 K  
 x : 0,4229  
 y : 0,3936  
 LambdaD : 583 nm  
 LambdaP : 631 nm

## CRI: 97,20

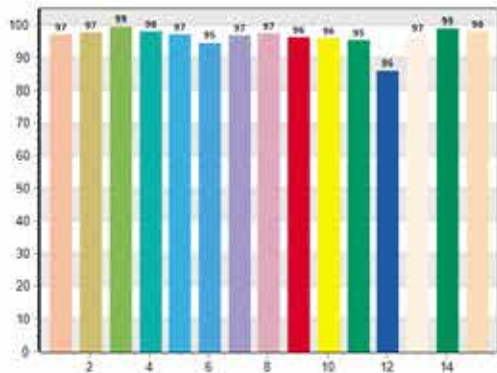

## CQS: 96,24

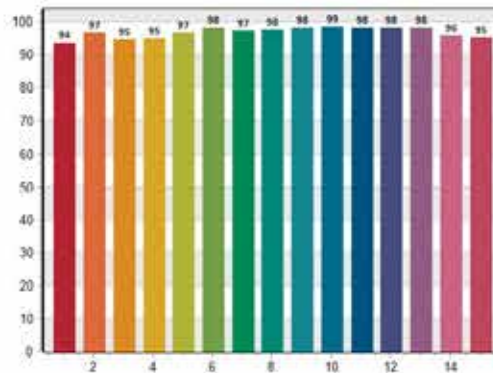

## CRI-2

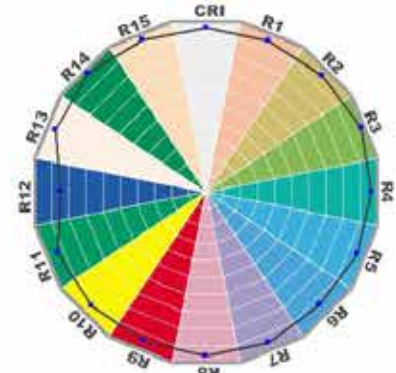

## TM30: 94,36

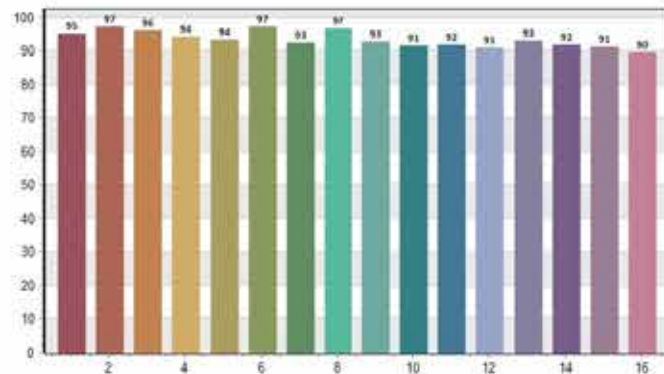

## TLCI: 98,05

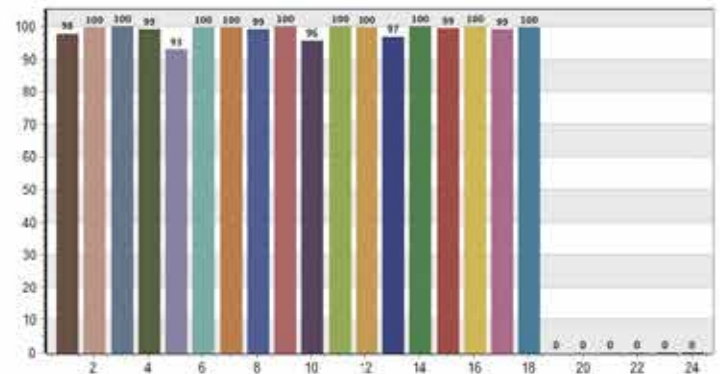

CRI values, only R1-R8 are used to calculate final CRI

R1	R2	R3	R4	R5	R6	R7	R8	R9	R10	R11	R12	R13	R14	R15
97,1	97,3	99,4	98,0	97,0	94,8	96,8	97,2	95,8	95,8	95,3	88,0	96,6	98,7	97,9

TM30 C values, 16 binned values out of total of 99 C values

C1	C2	C3	C4	C5	C6	C7	C8	C9	C10	C11	C12	C13	C14	C15	C16
95,3	97,2	96,0	94,2	93,5	97,3	92,5	96,5	92,7	91,5	92,0	90,9	93,2	91,8	91,2	89,6

CQS Q values

Q1	Q2	Q3	Q4	Q5	Q6	Q7	Q8	Q9	Q10	Q11	Q12	Q13	Q14	Q15
93,6	96,6	94,6	95,0	96,6	98,2	97,2	97,7	98,1	98,5	98,1	98,1	98,2	95,9	95,3

# REPORT OF THE TM30 TEST

**Rf 92,6**

Fidelity index Rf

**Rg 100,2**

Gammut index Rg

## ■ Spectrum

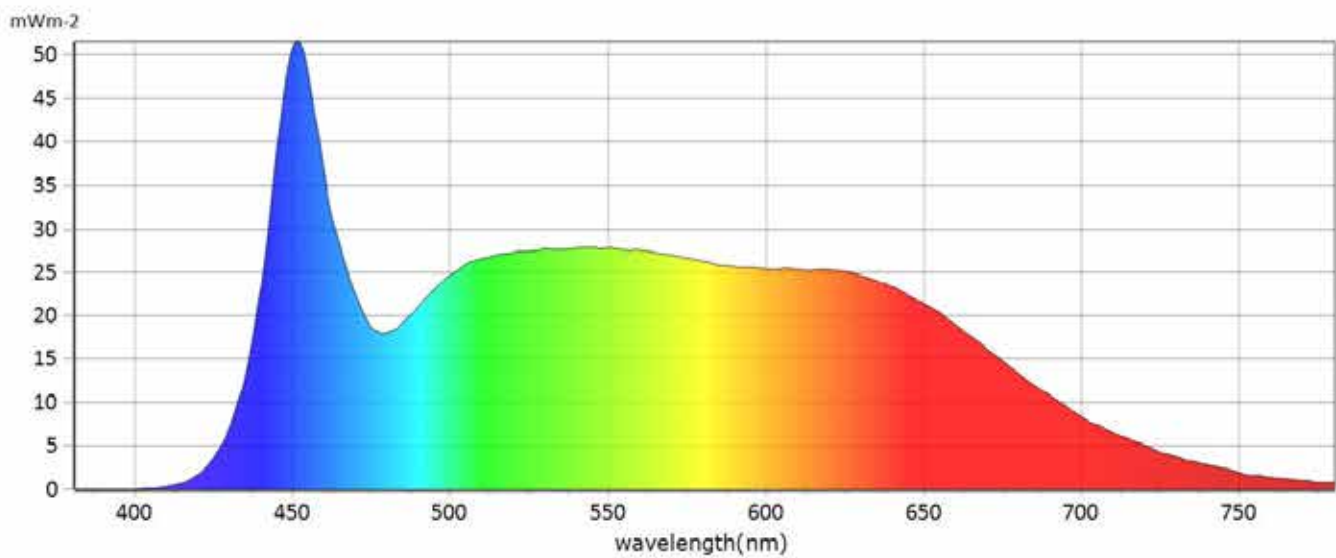

## ■ General Color Rendition

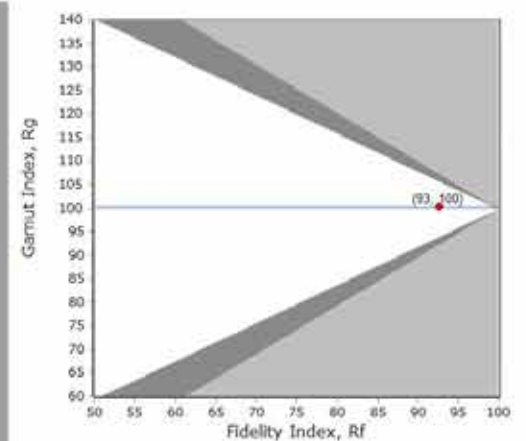
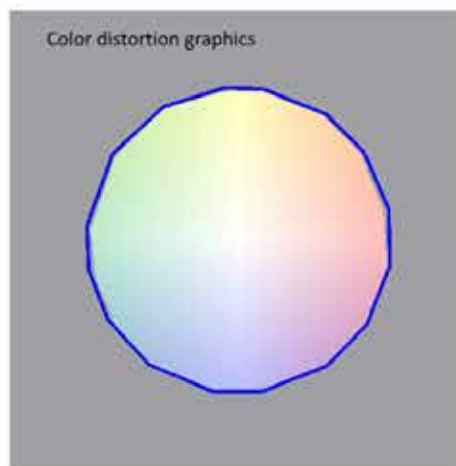
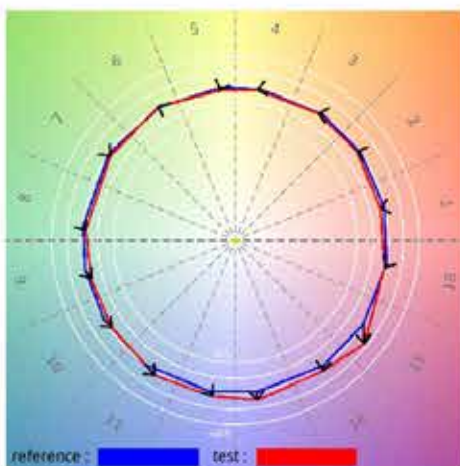

# REPORT OF THE TM30 TEST

**Rf 92,6**

Fidelity index Rf

**Rg 100,2**

Gammut index Rg

## Color Rendition by Hue

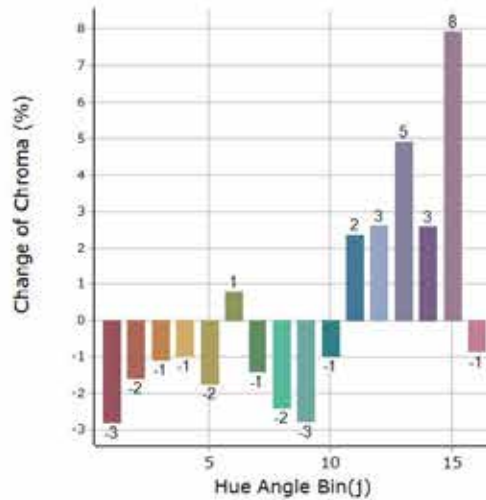
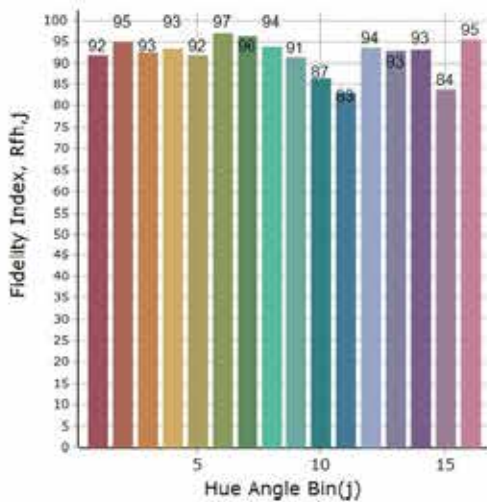

Hue Bin	Rf	Graphic shifts (%)	
		Chroma	Hue
1	91,9	-2,8%	-0,3%
2	95,1	-1,6%	1,6%
3	92,5	-1,1%	2,9%
4	93,4	-1,0%	1,5%
5	91,7	-1,7%	1,3%
6	96,9	0,8%	0,3%
7	96,3	-1,4%	0,3%
8	93,8	-2,4%	1,8%
9	91,3	-2,8%	6,4%
10	86,5	-1,0%	7,6%
11	83,1	2,4%	9,3%
12	93,7	2,6%	2,7%
13	93,0	4,9%	-0,6%
14	93,2	2,6%	-2,2%
15	83,9	7,9%	-10,3%
16	95,5	-0,9%	-1,9%

## Color Fidelity by Sample

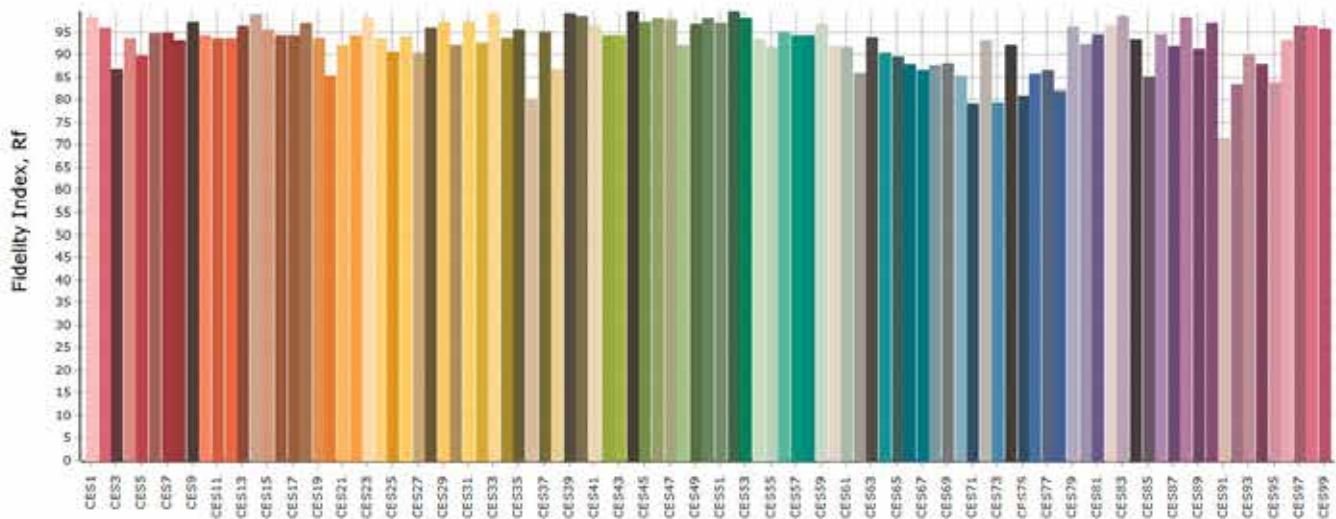

● Coemar Lighting S.r.l.

Via Carpenedolo, 90  
46043, Castiglione delle Stiviere (MN) – Italy

P. +39 0376 1514412

M1. info@coemar.com

M2. service@coemar.com

W. coemar.com

P.iva – C.f. 02415330204

