

MiniLEDko Family

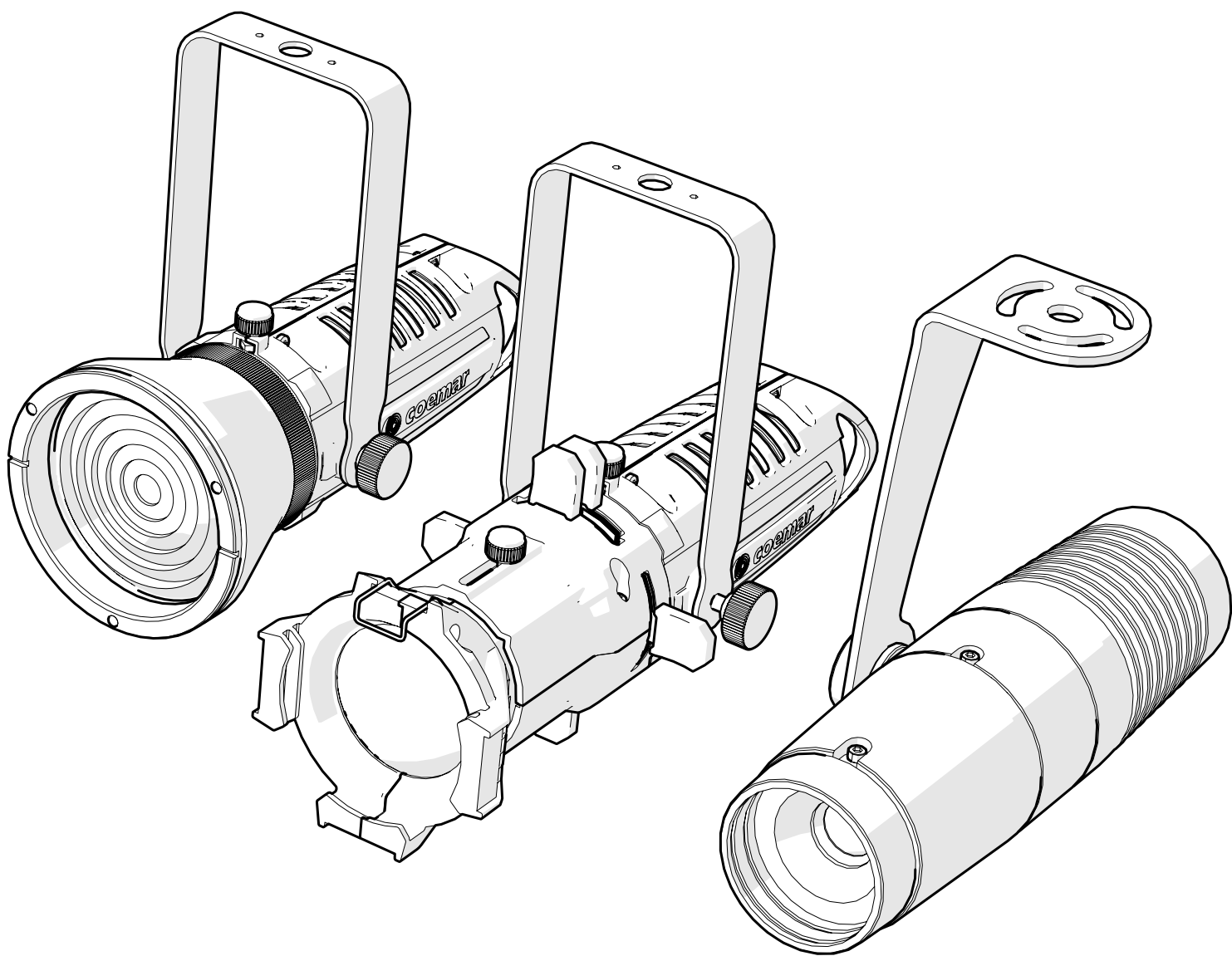

**PROVISIONAL
USER MANUAL**
vrs. 1.5 - 23.02.2024



 **coemar**

© 2023 Coemar Lighting Srl. All rights reserved.

Information subject to change without notice. Coemar and all affiliated companies disclaim liability for any injury, damage, direct or indirect loss, consequential or economic loss or any other loss occasioned by the use of, inability to use or reliance on the information contained in this document. The Coemar logo, the Coemar name and all other trade-marks in this document pertaining to services or products by Coemar or its affiliates and subsidiaries are trademarks or licensed by Coemar or its affiliates or subsidiaries.

No part of this document may be used for distribution, reproduction, transmission, transcription, storage in a data retrieval system, or translated into any language in any form by any means without the prior written permission of Coemar ®. If you are downloading files from our web pages for your personal use, make sure to check for updated versions. Coemar ® cannot take any liability whatsoever for downloaded files, as technical data are subject to change without notice.

Congratulations on having purchased a **Coemar** product. You have assured yourself of a fixture of the highest quality, both in componentry and in the technology used. We renew our invitation to you to complete the service information on the previous page, to expedite any request for service information or spares (in case of problems encountered either during, or subsequent to, installation). This information will assist in providing prompt and accurate advice from your **Coemar** service centre. Following the instructions and procedures outlined in this manual will ensure the maximum efficiency of this product for years to come.

Index

1. Packaging and transportation	Pag. 5
1.1. Packaging	Pag. 5
1.2. Transportation	Pag. 5
2. General information	Pag. 5
2.1 Safety informations	Pag. 5
2.2 Warranty conditions	Pag. 6
2.3 EC Norms	Pag. 6
3. Product specifications	Pag. 7
3.1 Technical characteristics	Pag. 7
3.2 Available models	Pag. 7
3.3 Dimensions - MiniLEDko Profile with Lens Tube	Pag. 8
3.4 Dimensions - MiniLEDko Profile with Profile Zoom	Pag. 10
3.5 Dimensions - MiniLEDko Fresnel	Pag. 12
3.6 Dimensions - MiniLEDko Fresnel with 4-leaf Barndoor	Pag. 14
3.7 Dimensions - MiniLEDko Spot	Pag. 16
3.8 Unit's main components - MiniLEDko Profile	Pag. 18
3.9 Unit's main components - MiniLEDko Fresnel	Pag. 19
3.10 Unit's main components - MiniLEDko Spot	Pag. 20
4. Installation	Pag. 21
4.1 Mechanical installation	Pag. 21
4.2 Compatible Track System - DALI, DMX versions - Table A	Pag. 21
4.3 On/Off, On board potentiometer, Bluetooth App versions - Table B	Pag. 22
4.4 Track-mount version installation	Pag. 23
4.5 Integrated driver Track-mount version installation	Pag. 23
4.6 Portable version installation	Pag. 25
4.7 Portable version installation	Pag. 25
4.3 Canopy version installation	Pag. 26
5. MiniLEDko Profile optical adjustments	Pag. 27
5.1 Adjusting MiniLEDko Profile and Fresnel's tilt	Pag. 27
5.2 How to adjust the MiniLEDko Profile's focus	Pag. 28
5.3 How to shape the MiniLEDko Profile's Beam with Shutters	Pag. 28
5.4 How to insert a gobo into the MiniLEDko Profile	Pag. 29
6. MiniLEDko Fresnel optical adjustments	Pag. 31
6.1 Adjusting unit's tilt	Pag. 31
6.2 How to adjust the MiniLEDko Fresnel's Zoom	Pag. 32

7. MiniLEDko Spot optical adjustments	Pag. 33
7.1 Adjusting unit's tilt.....	Pag. 33
7.2 How to adjust the focus.....	Pag. 33
7.3 How to mount the gobo.....	Pag. 34
7.4 How to change the optic.....	Pag. 36
8. DMX/DALI Connection	Pag. 38
9. Setup via RDM	Pag. 39
9.1 Quick guide to menu	Pag. 39
9.2 RDM Chart	Pag. 39
9.3 RDM Error Chart	Pag. 40
10. DMX chart - Fixed White version	Pag. 41
10.1 DMX modes	Pag. 41
10.2 DMX Chart 5/1 channels	Pag. 42
11. DMX chart - VariWhite version	Pag. 43
11.1 DMX modes	Pag. 43
11.2 DMX Chart 5 channels	Pag. 44
11.3 DMX Chart 2 / 1 channels.....	Pag. 45
11.4 DMX Chart Sunrise mode.....	Pag. 45
11.5 DMX Chart Raw mode.....	Pag. 46
11.6 DMX Chart 2 channels (MK1).....	Pag. 47
11.7 DMX Chart 6 channels.....	Pag. 48
12. Connect and use a MiniLEDko via Bluetooth	Pag. 50
13. Accessories and spare parts	Pag. 55
13.1 MiniLEDko Profile	Pag. 55
13.2 MiniLEDko Fresnel	Pag. 55
13.3 MiniLEDko Spot	Pag. 56
14. Maintenance	Pag. 57
14.1 Firmware update.....	Pag. 57
14.2 Periodic cleaning.....	Pag. 57
14.3 Periodic controls.....	Pag. 57
15. F.A.Q. and answers	Pag. 58

1. Packaging and transportation

1.1 Packaging

Open the packaging and make sure that no part of the equipment has suffered any damage during the transportation. In case of damage to the fixture, contact your carrier and your supplier immediately by telephone, fax or e-mail, and inform them you will formally notify them in writing through registered letter.

Packing list

Ensure the packaging contains:

1 MiniLEDko

1 Instruction manual

1.2 Transportation

The **MiniLEDko** should be transported in either its original packaging or in an appropriate flight case.

2. General information

2.1 Safety informations

Fire prevention:



1. Never locate the fixture on any flammable surface.
2. Minimum distance from flammable materials: 0,5 m.
3. Minimum distance from the closet illuminable surface: 0,5 m.
4. Connect the projector to mains power protected by a thermal magnetic circuit breaker.

Prevention from electric shock:



1. Presence of high voltage inside of the fixture. Insulate the projector from mains supply before opening or performing any function which involves touching the inside of the fixture, including LED replacement.
2. For the connection to the mains, adhere strictly to the guidelines outlined in this manual.

3. The level of technology of **MiniLEDko** requires the use of specialised personnel for all service applications; refer all work to your authorised **Coemar** service centre.
4. A good earth connection is essential for the proper functioning of the projector. Never connect the fixture if there is no earth connection.
5. Mains cables must not come into contact with other cables.
6. Do not operate the projector with wet hands or in an area where water is present.
7. The fixture must never be located in an exposed position, or in areas of extreme humidity.

Safety:



1. The projector must always be installed with bolts, clamps, or other fixing devices which are suitably rated to support the weight of the projector.
2. Always use a secondary safety fixing device with chain or steel wire of a suitable rating to sustain the weight of the unit in case of failure of the principal fixing point.
3. The external surfaces of the unit, at various points, may reach 60°C. Never handle the unit until at least 10 minutes have elapsed since the LED was turned off.
4. Never install the fixture in an enclosed area lacking sufficient air flow; the ambient temperature must not exceed 40°C.
5. The projector contains electronic and electrical components which must under no circumstances be in contact with water, oil or any other liquid. Failure to do so will compromise the proper functioning of the projector.

2.2 Warranty conditions

1. The fixture is under warranty for 24 months from the purchase date against factory defections.
2. Damage ought to unskillfulness, inappropriate use, or lack of suggested maintenance are excluded from the warranty.
3. Warranty expires when the projector is opened by unauthorized personnel.
4. Warranty doesn't include the replacement of the fixture.
5. Serial number and model of the fixture are necessary to retrieve informations and assistance from the dealer.

2.3 EC Norms

1. The fixture satisfies the essential requirements of the directive 2004/108/EC, 2006/95/EC, 2011/65/EC, 2002/96/EC & 2003/108/EC.
2. The fixture is in accordance with the standard EN 50419 (RoHS) and satisfies the requirements of the directive 2002/96/EC (WEEE).

3. Product specifications

3.1 Technical characteristics

Power supply	Depending on the Power Supply mounted on the fixture (check the operating voltage on the technical label on the MiniLEDko)
Maximum current	0.07 A at 230 V, 0.15 A at 115 V
Power factor	$\text{Cos}\varphi = 0.9$
Max power consumption	20 W
LED Source	Fixed White: 25 W White COB LED VariWhite version: 35 W COB LED
CCT	Fixed White version: 3.000 K, 5.600 K (On request available 2.700 K, 3.500 K, 4.000 K, 5.000 K, 6.500 K) VariWhite version: 2.700 K → 6.500 K
Color Rendering Index (CRI)	Fixed White version: CRI > 96 (96 @3200 K, 97 @5600 K) TLCI >98 (98 @3200 K, 99 @5600 K) VariWhite version: CRI >93 TLCI >95
Weight (without optic)	1.5 Kg / 3.31 lbs
Ambient Operating Temperature	0°C - +40°C (32°F - 104°F)
IP rating	20 or 65 (only MiniLEDko Spot portable version)

3.2 Available models

MiniLEDko family		LED source		Color		Mounting Options		IP		Control	
Profile	F113	T (CRI>95)	A	Black	0	None	A	IP20	0	None	A
Fresnel	F115	D (CRI>95)	B	Silver	1	Track	B	IP65 (MiniLEDko Spot only)	1	DMX Control	B
Spot	F116	Vari White	G	White	2	Portable	C			DALI Control	C
				Custom	X	Canopy	D			Bluetooth App Control	D
										On Board Potentiometer Control	E
										On-Off Control	F

3.3 Dimensions - MiniLEDko Profile with Lens Tube

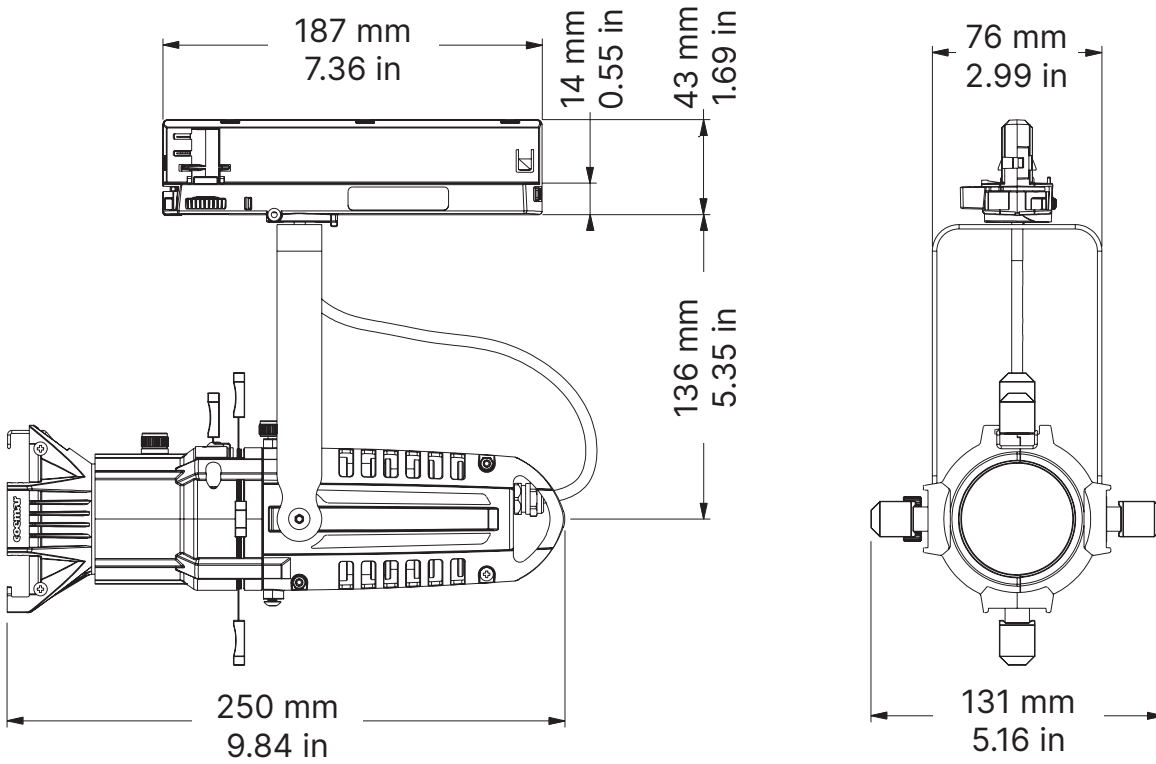

Track version with potentiometer on-board

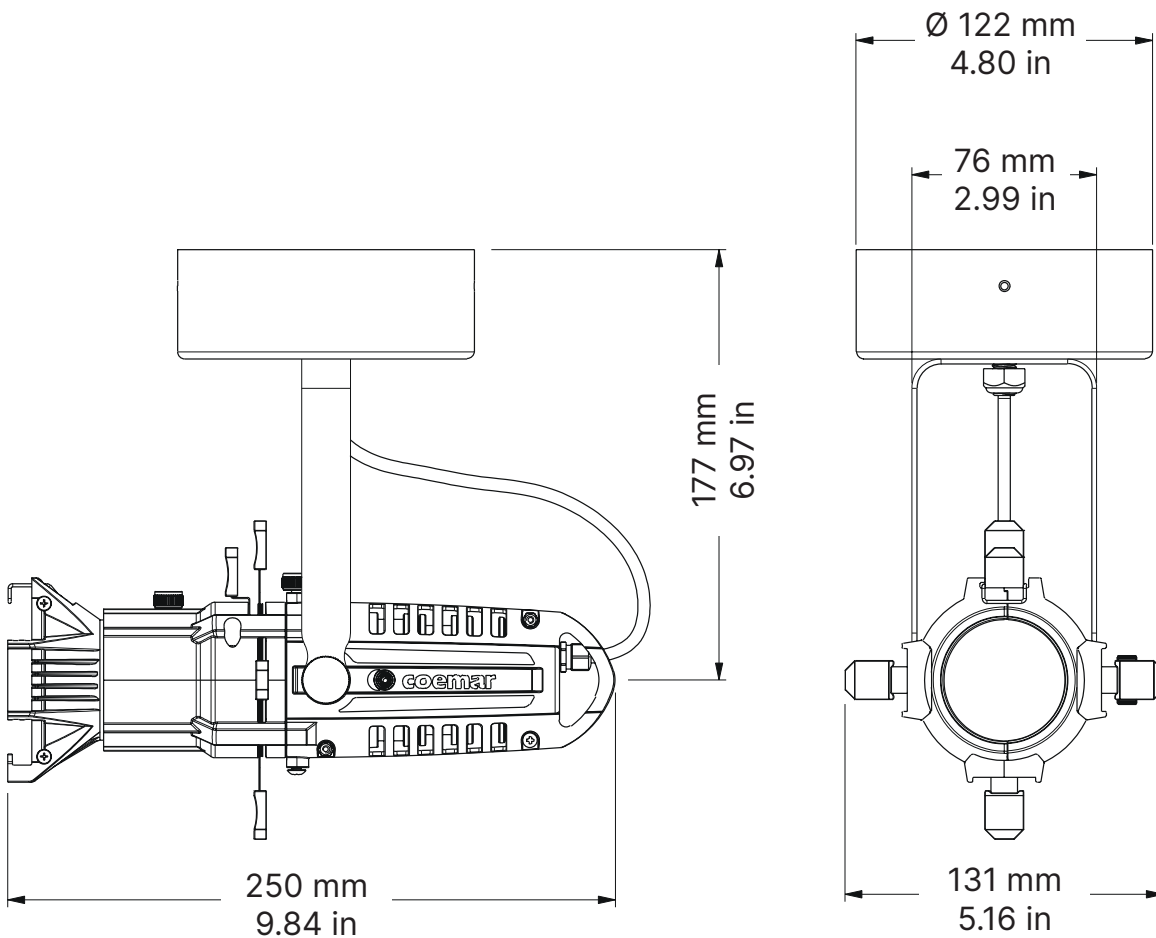

Canopy version

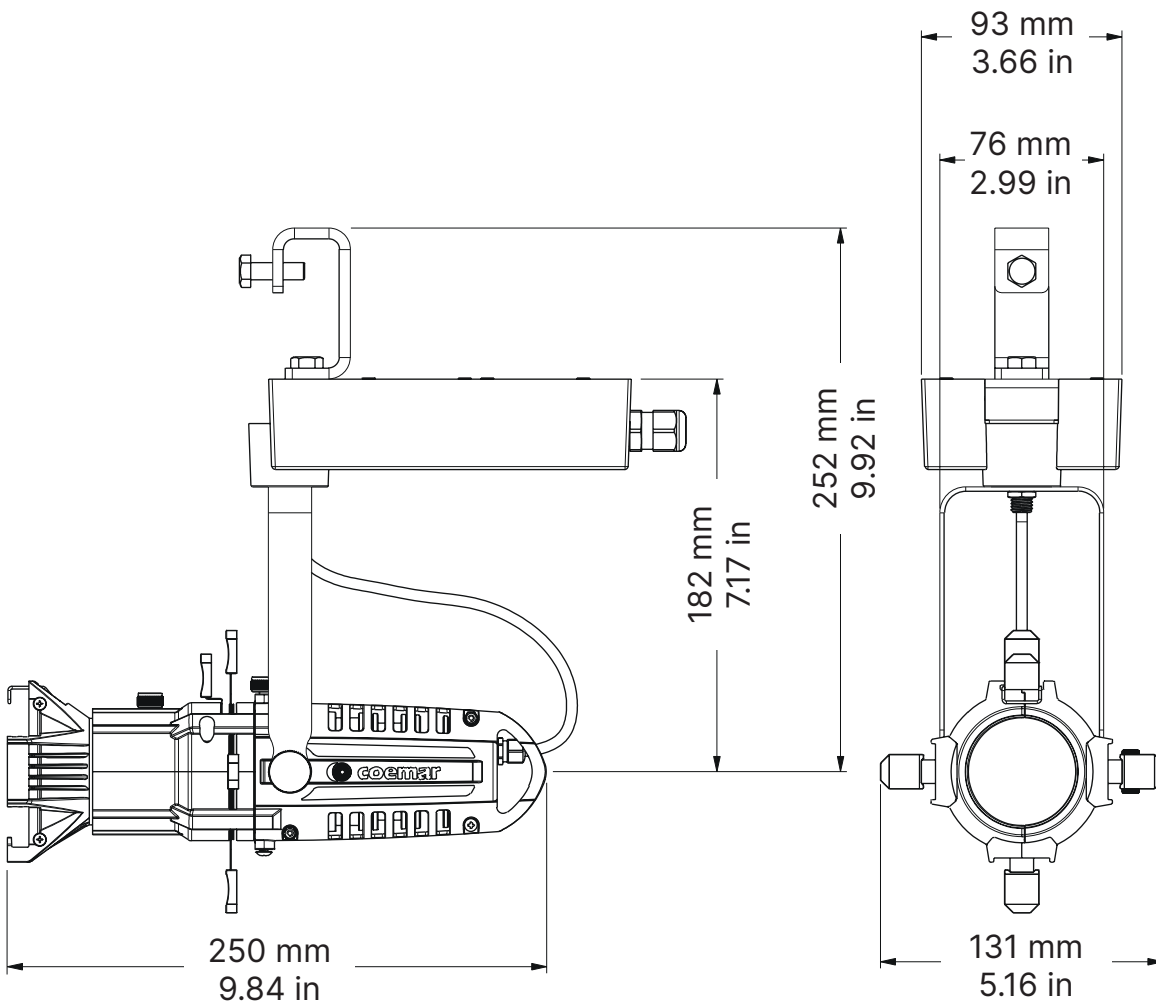

Portable version

*Hook with M8 Thread

3.4 Dimensions - MiniLEDko Profile with Profile Zoom

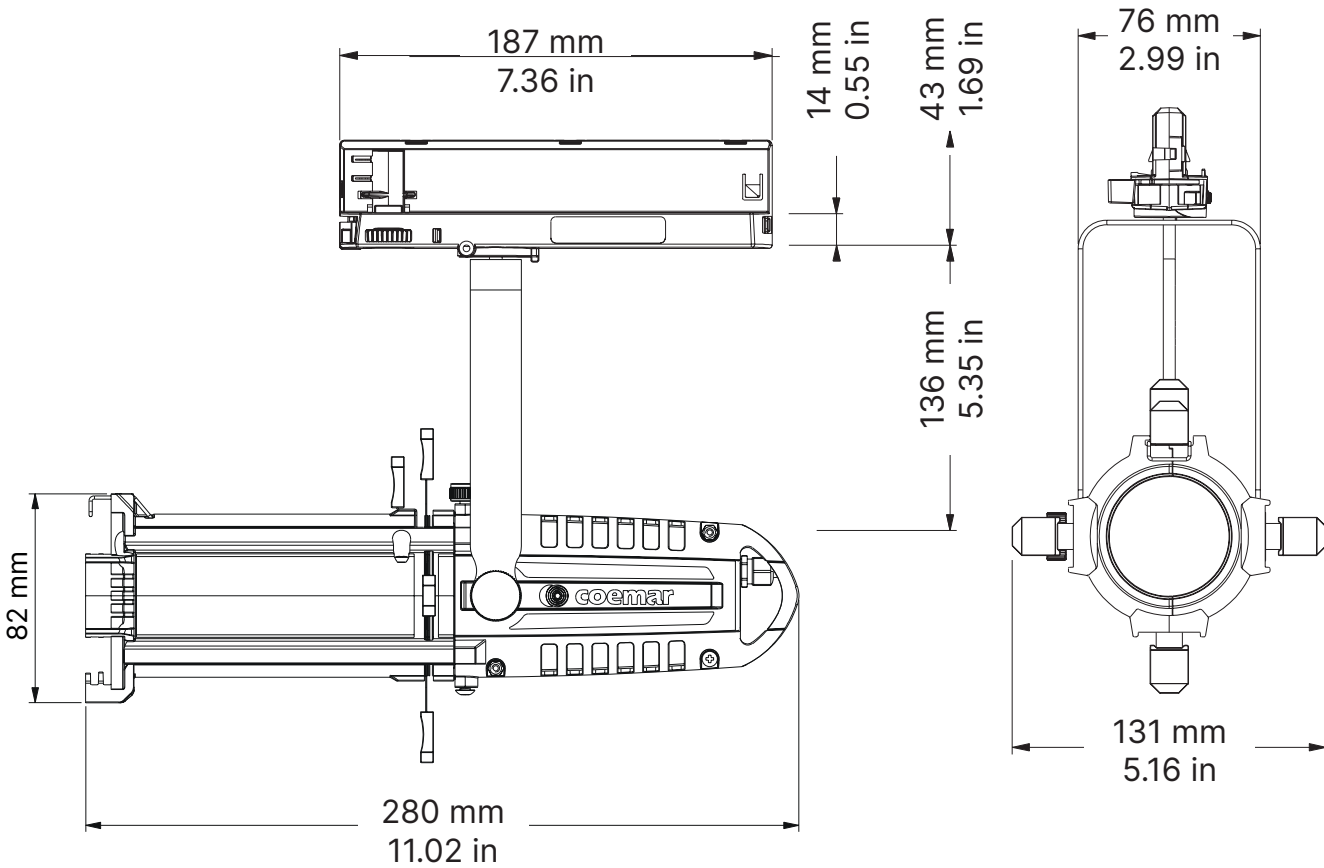

Track version with potentiometer on-board

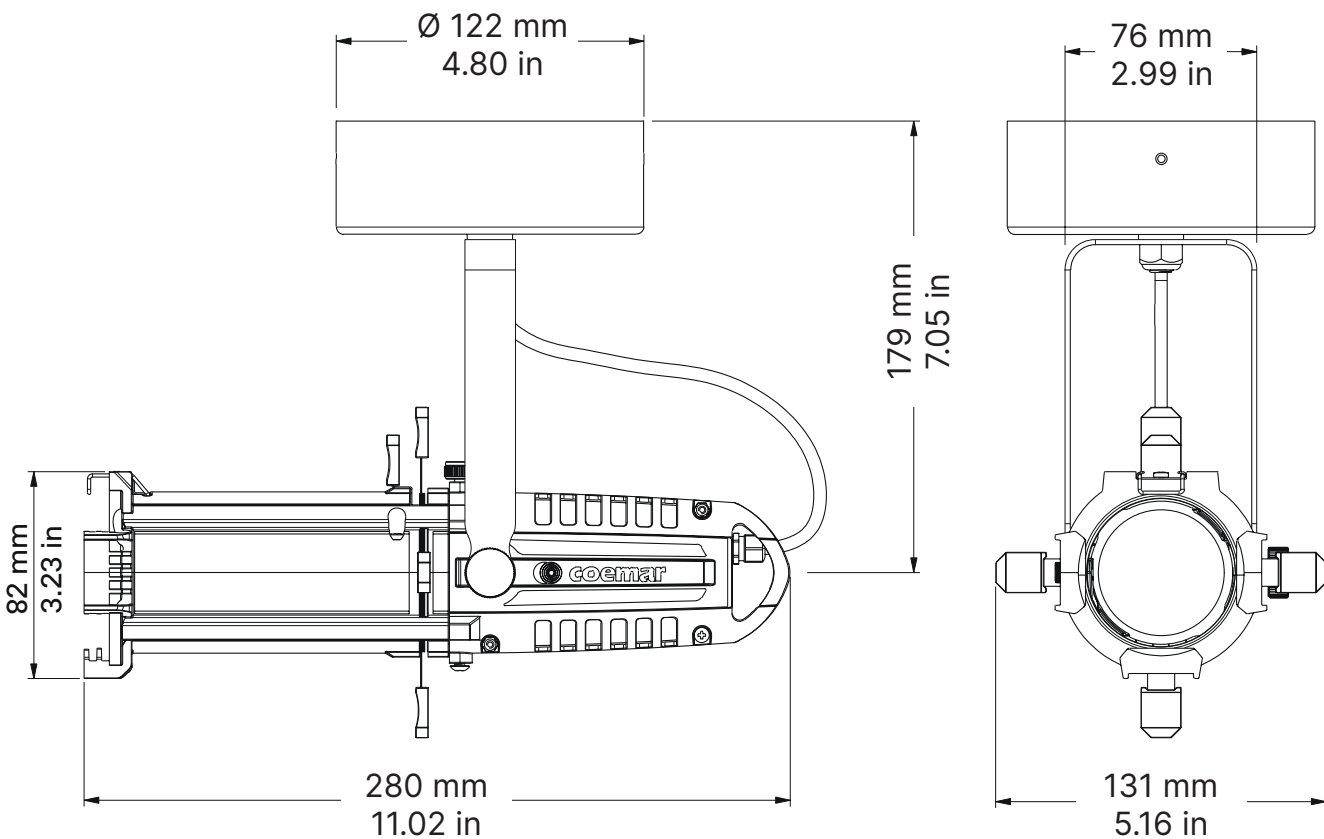

Canopy version

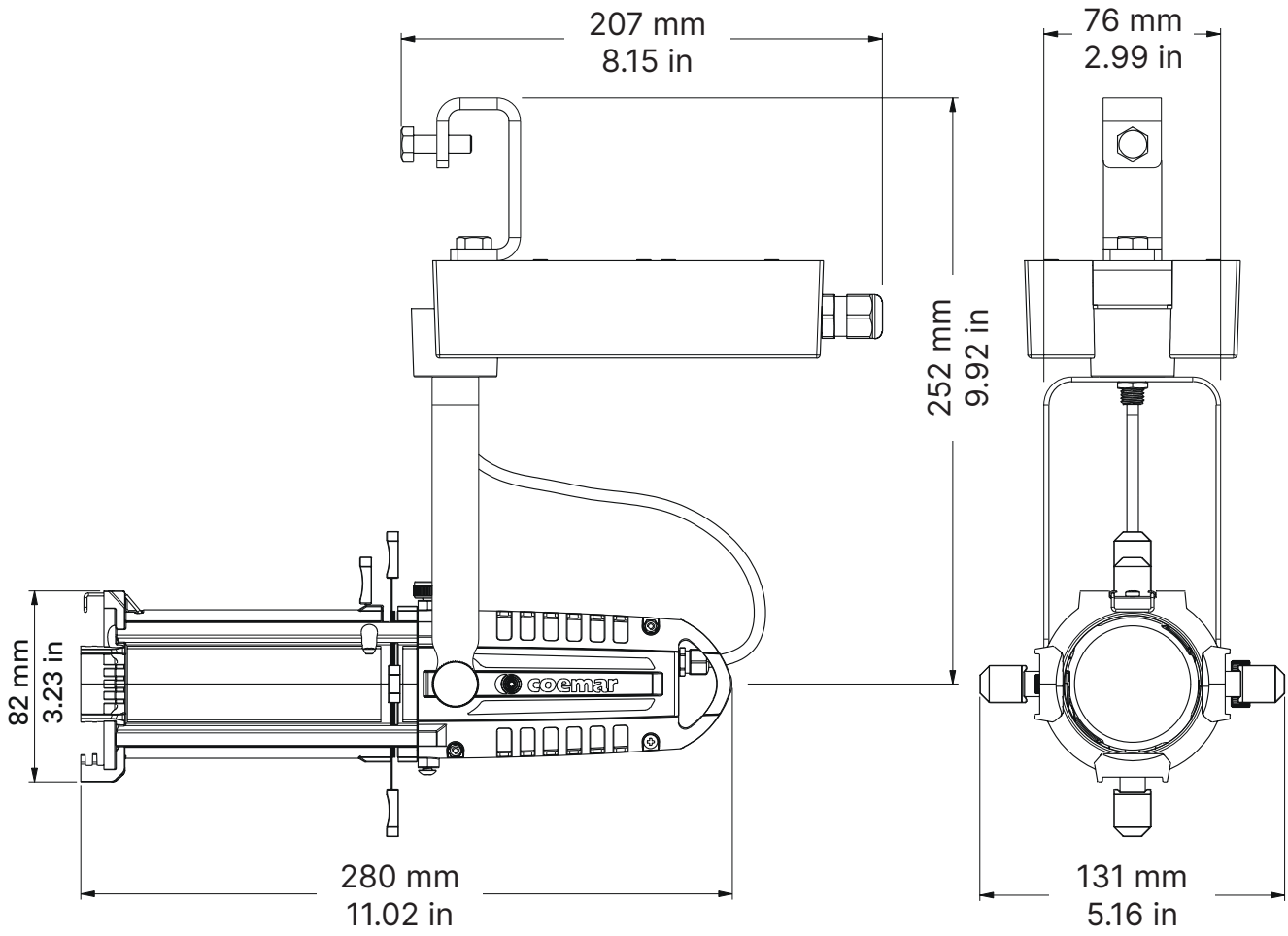

Portable version

*Hook with M8 Thread

3.5 Dimensions - MiniLEDko Fresnel

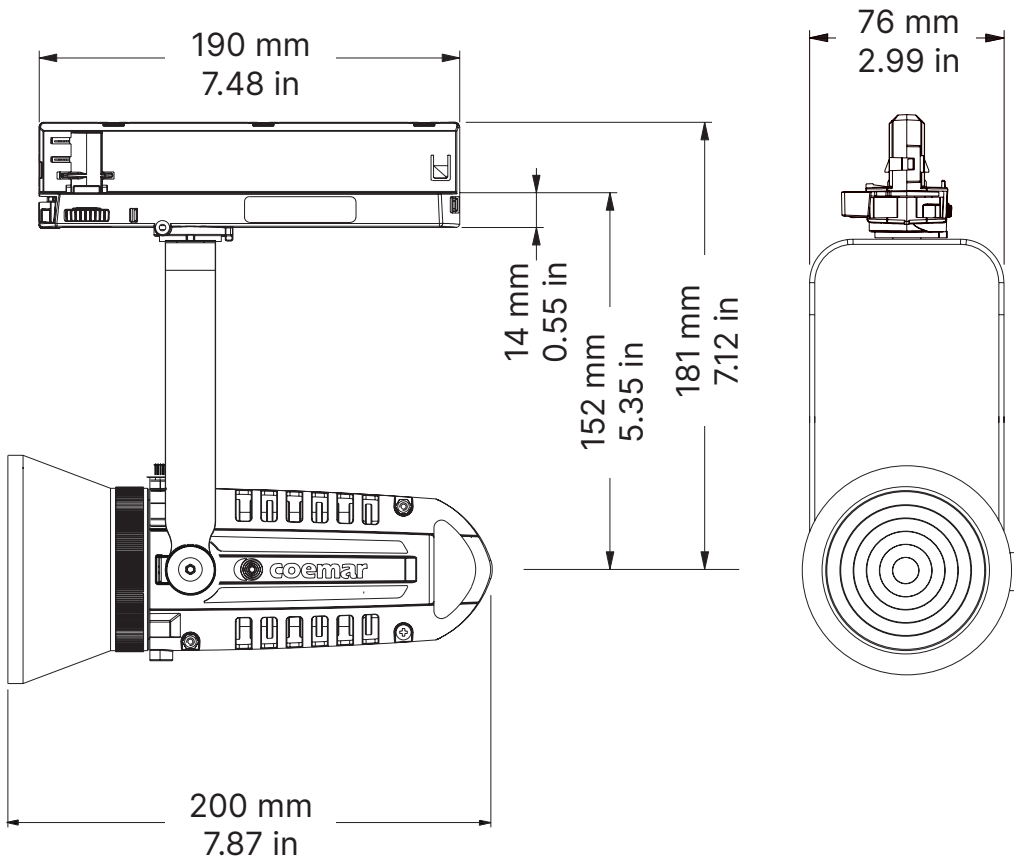

Track version with potentiometer on-board

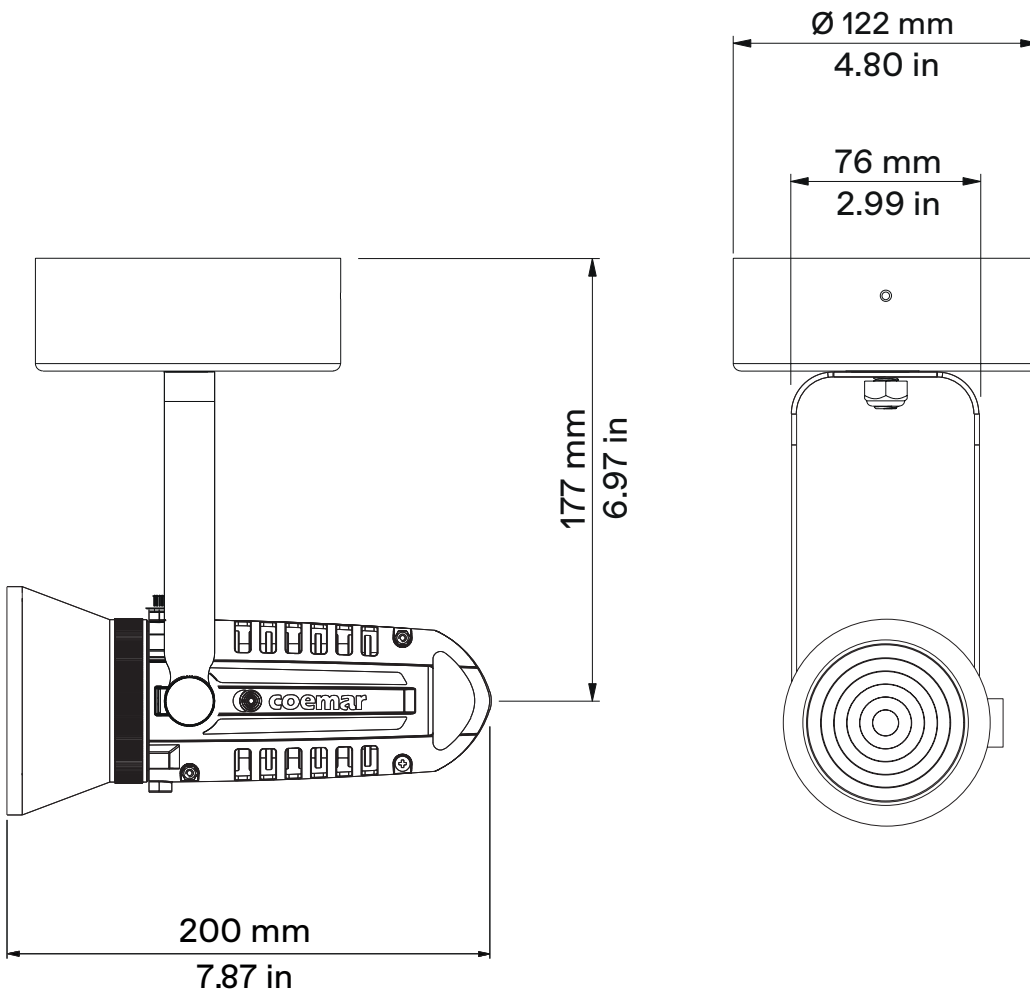

Canopy version

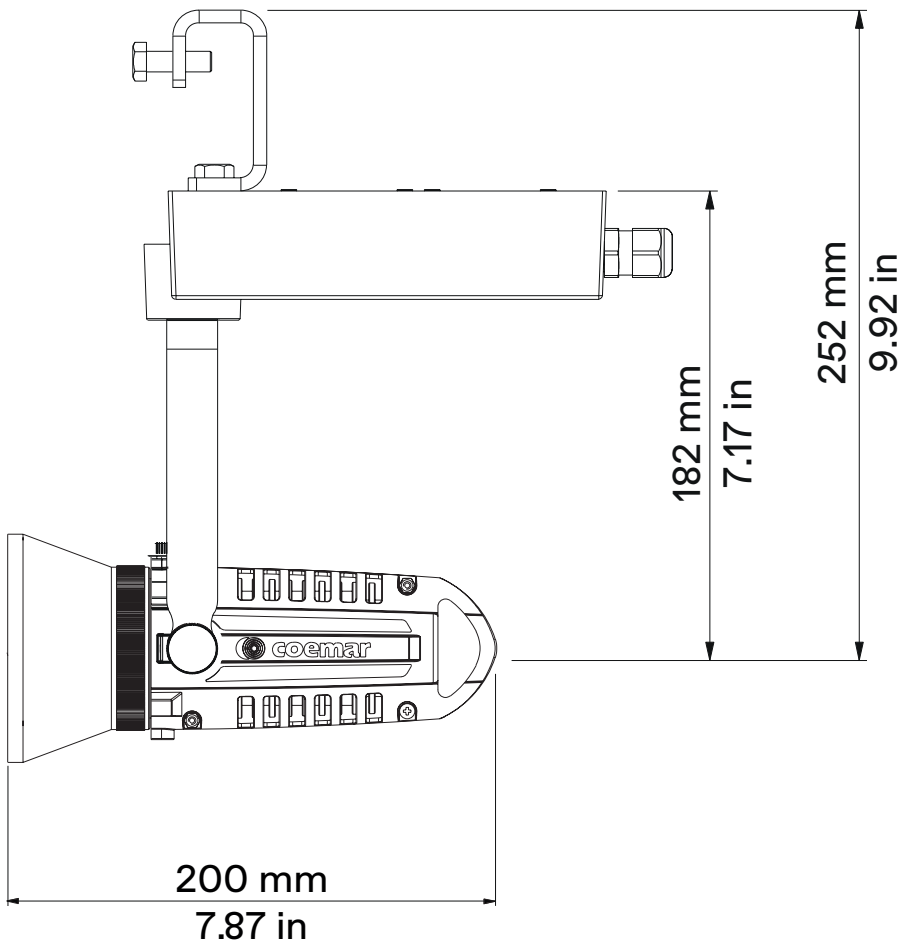

Portable version

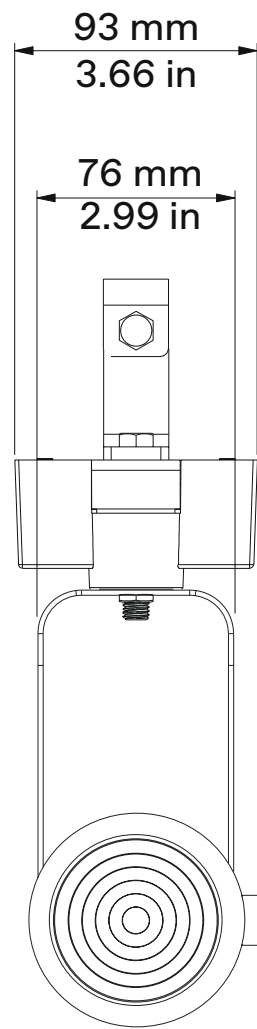

*Hook with M8 Thread

3.6 Dimensions - MiniLEDko Fresnel with 4-leaf Barndoor

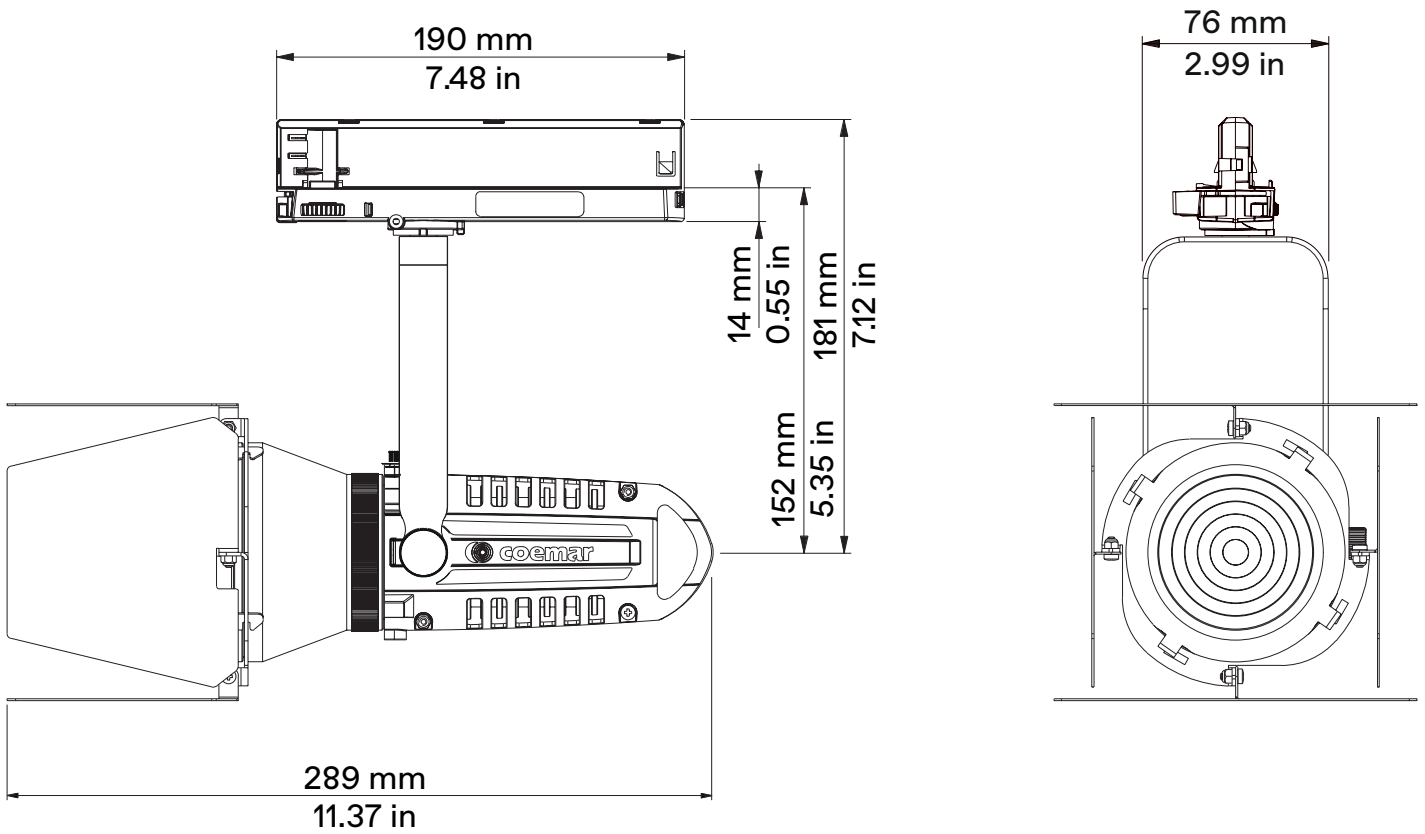

Track version with potentiometer on-board

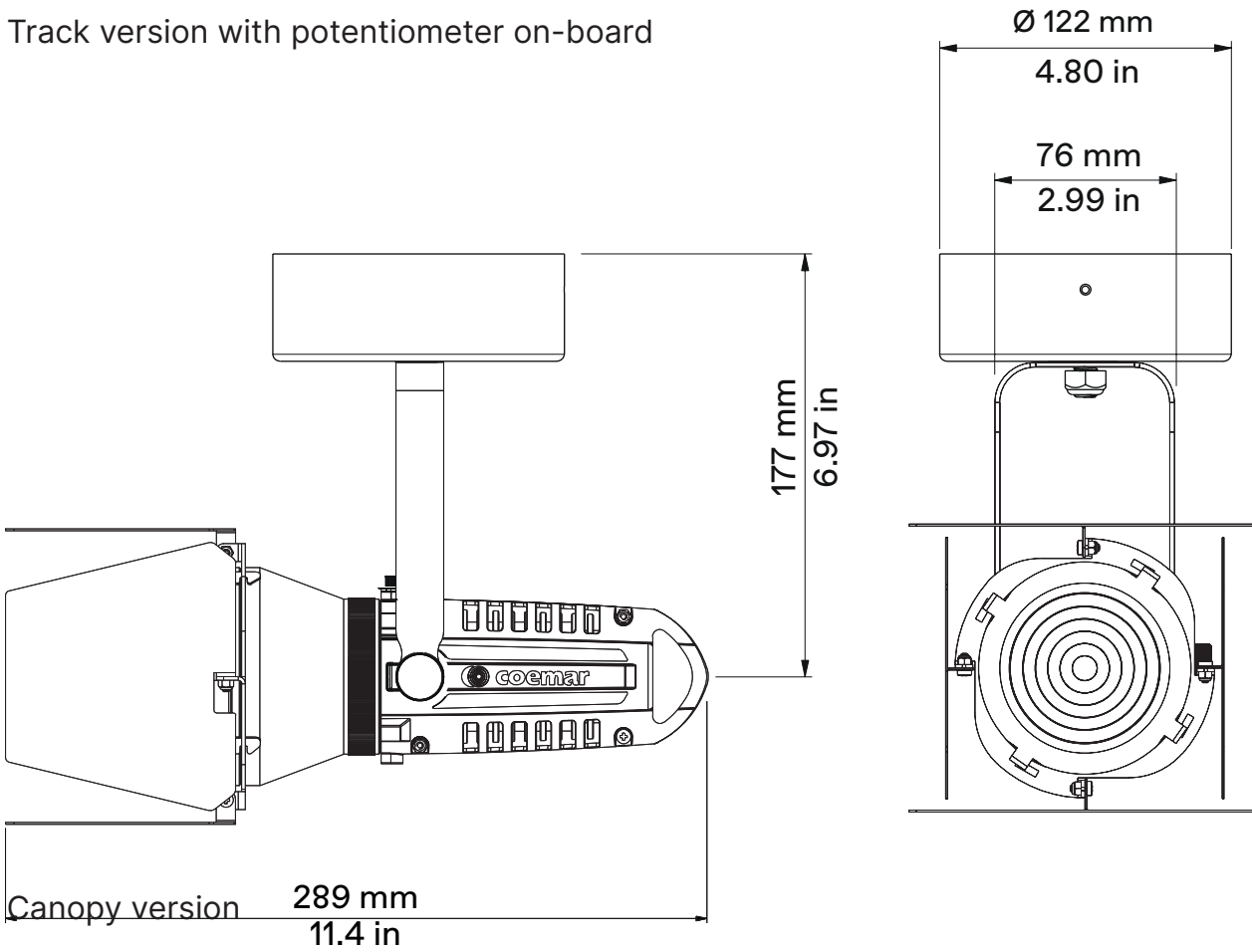

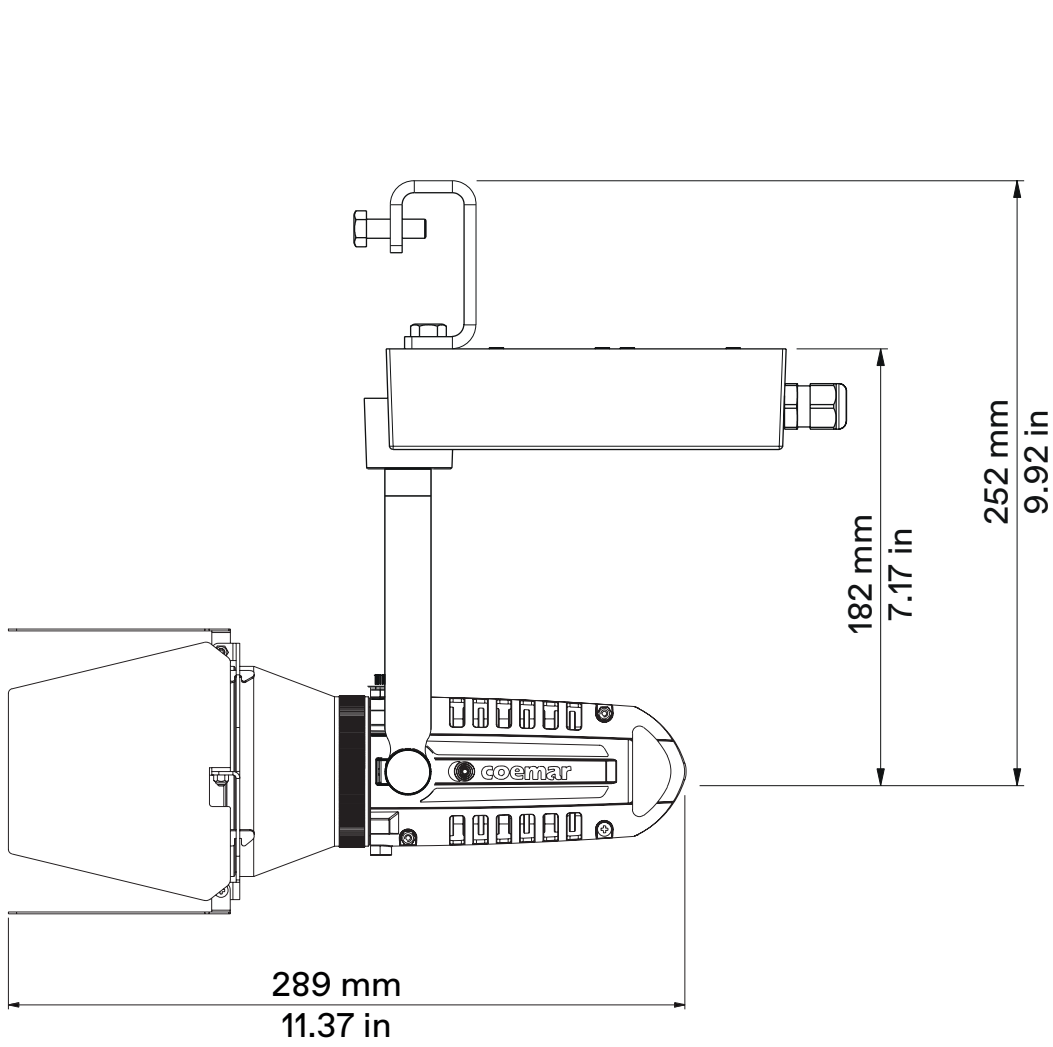

Portable version

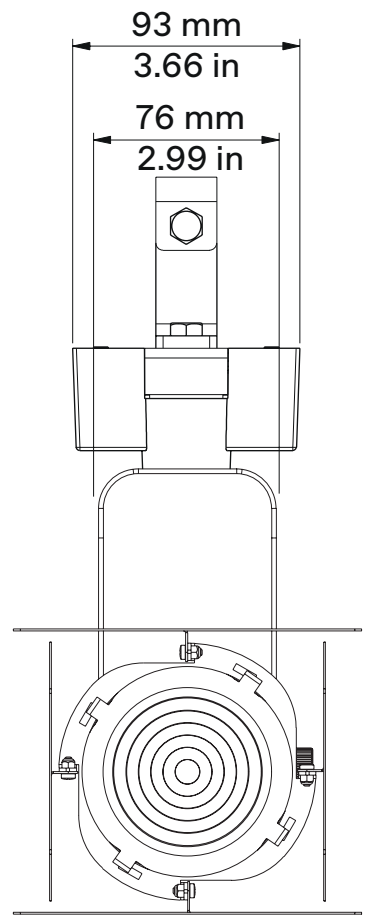

*Hook with M8 Thread

3.7 Dimensions - MiniLEDko Spot

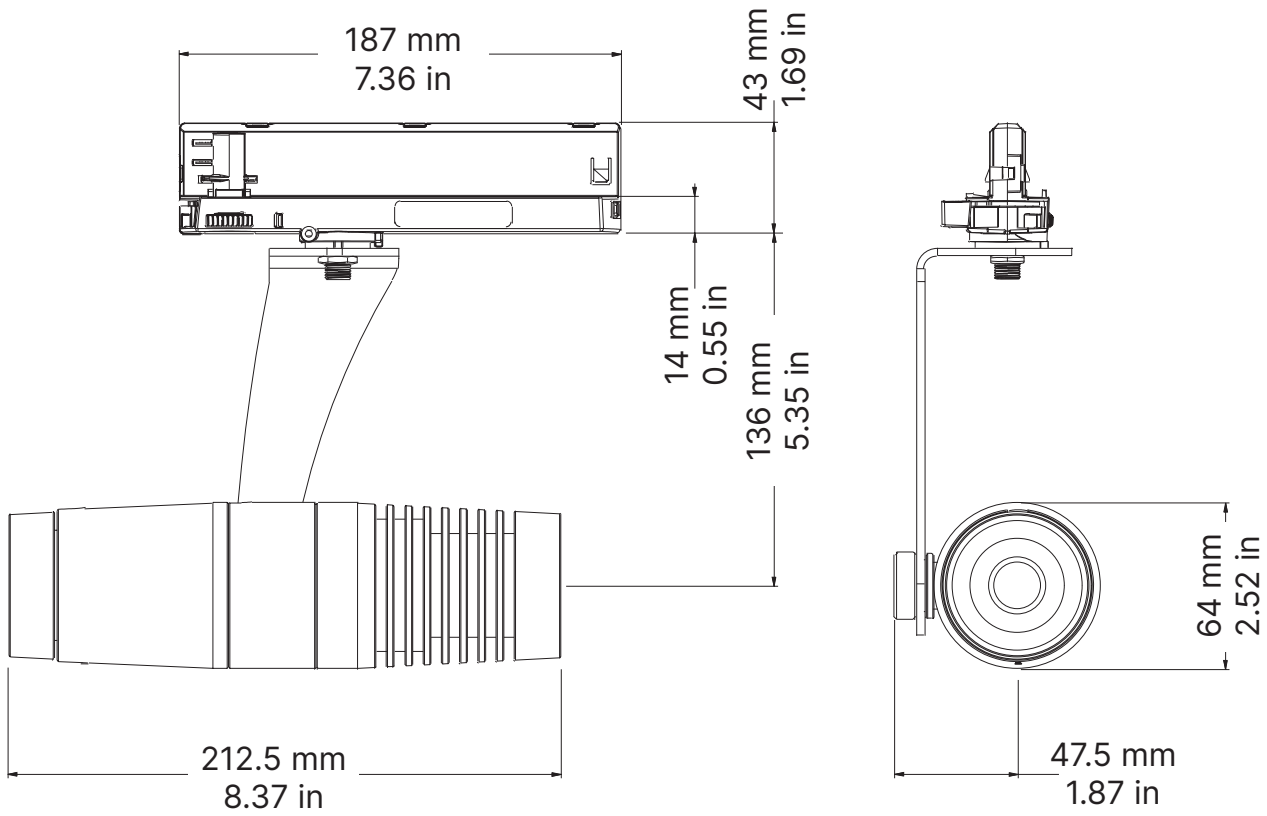

Track version with potentiometer on-board

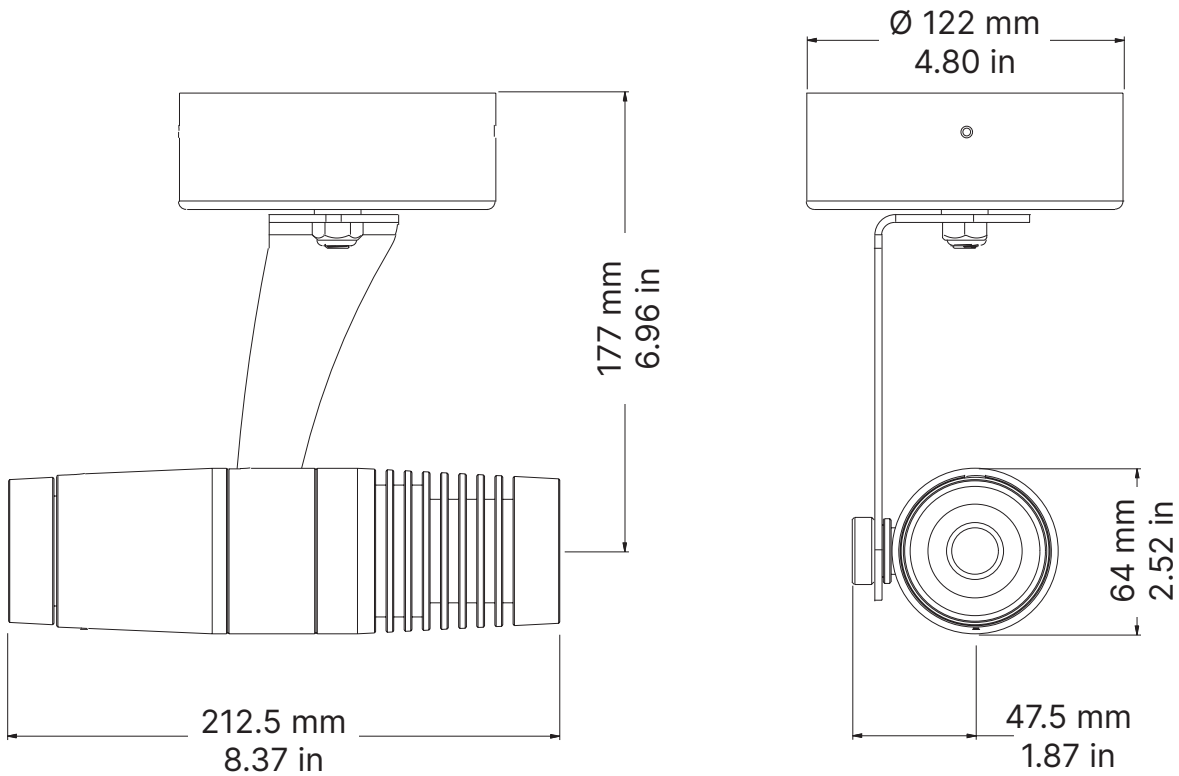

Canopy version

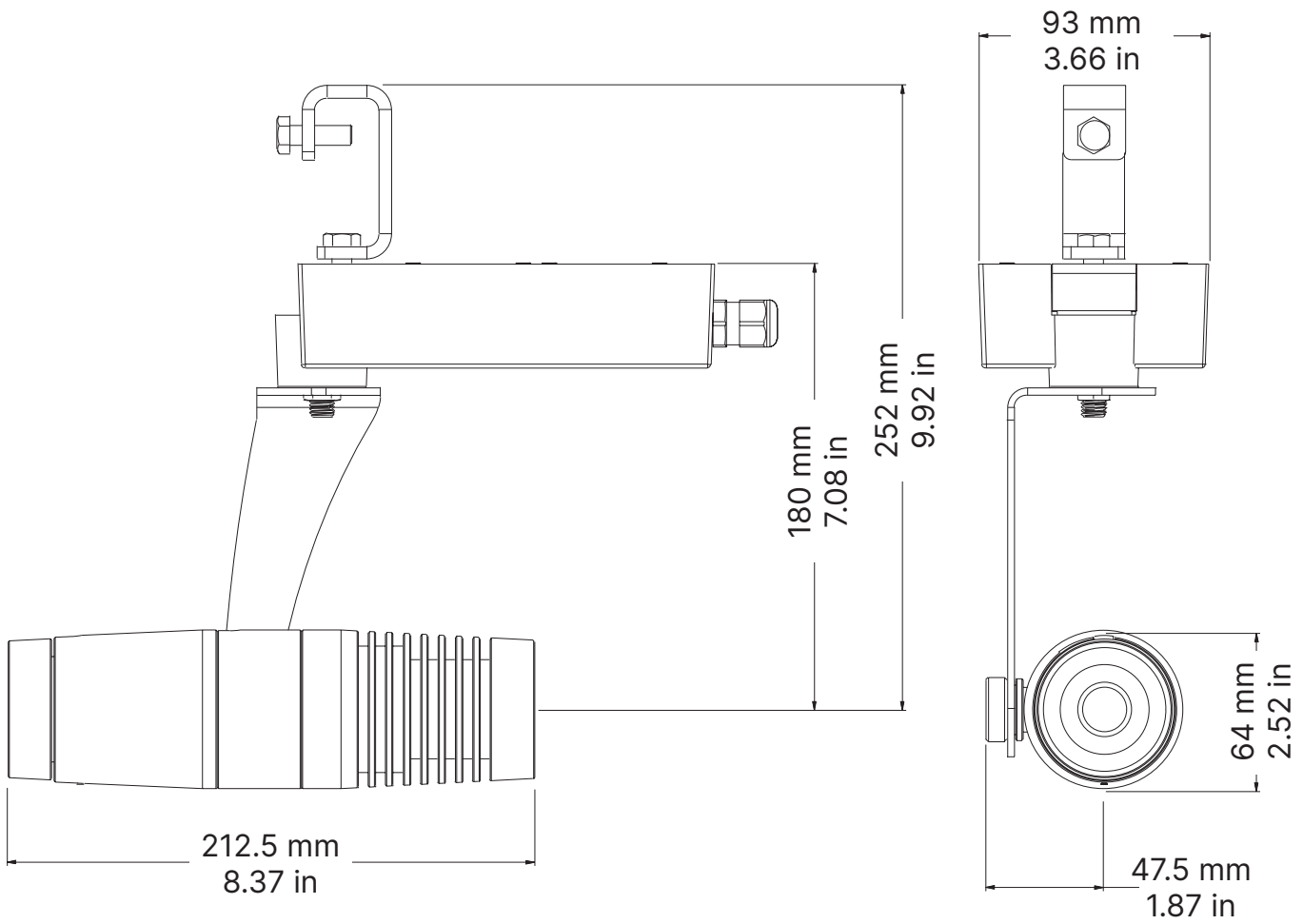

Portable version

*Hook with M8 Thread

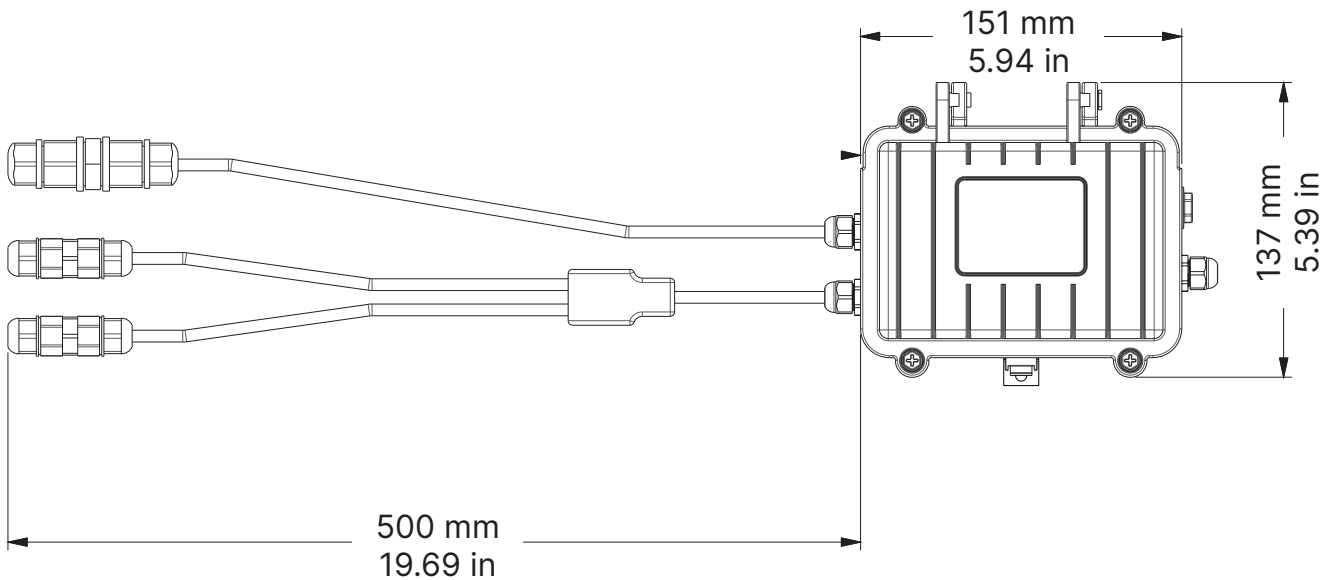
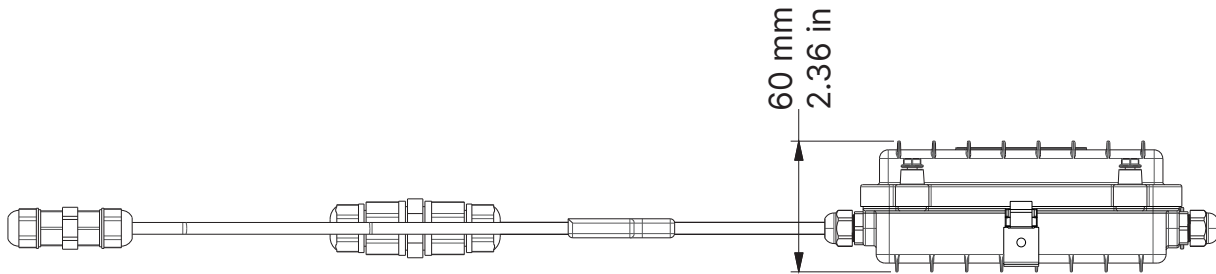

3.8 Unit's main components - MiniLEDko Profile

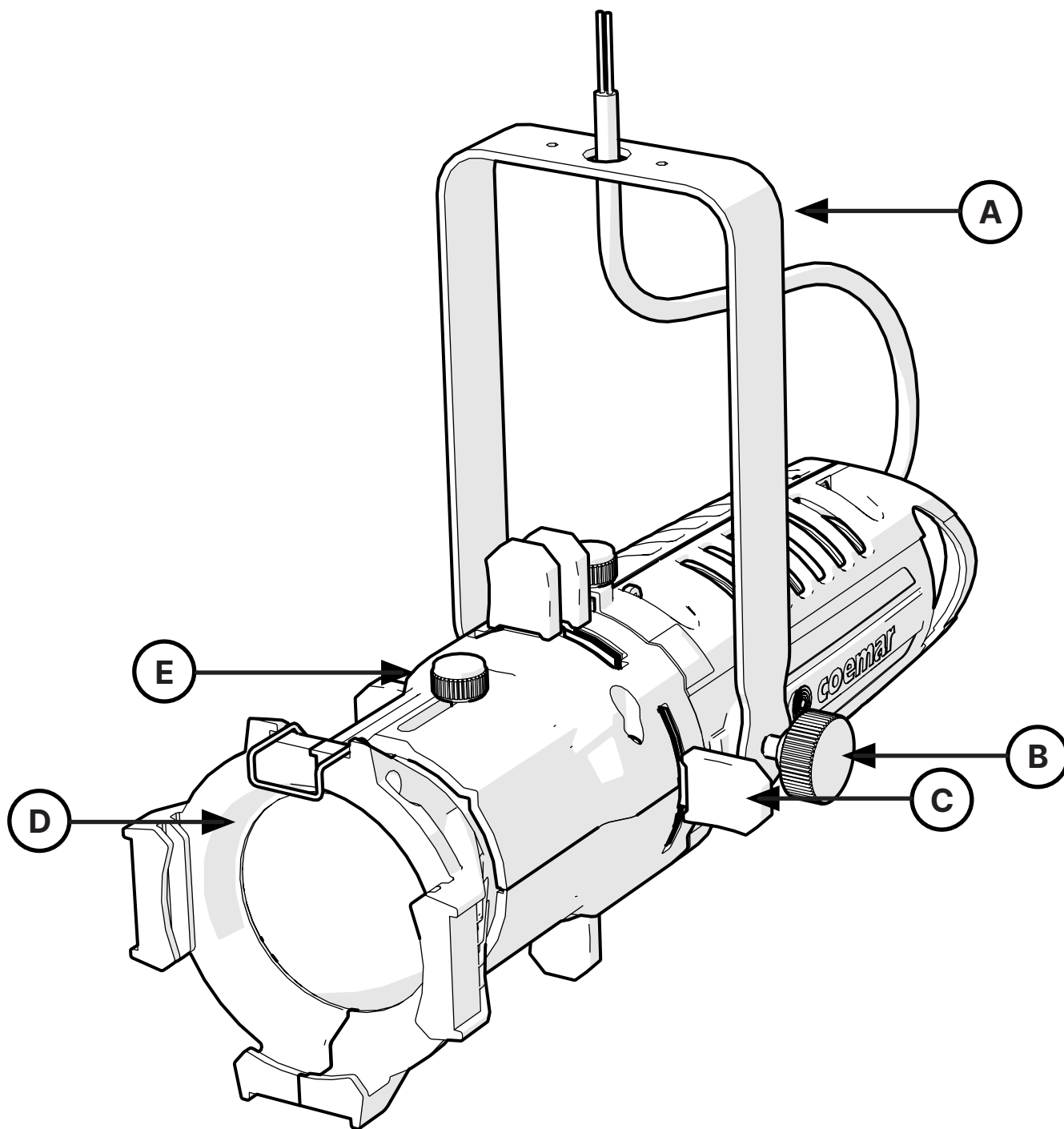

Components description

Components description	
A	Adjustable yoke
B	Yoke adjusting screws
C	Profile blade
D	Lens (interchangeable)
E	Lens knob

3.9 Unit's main components - MiniLEDko Fresnel

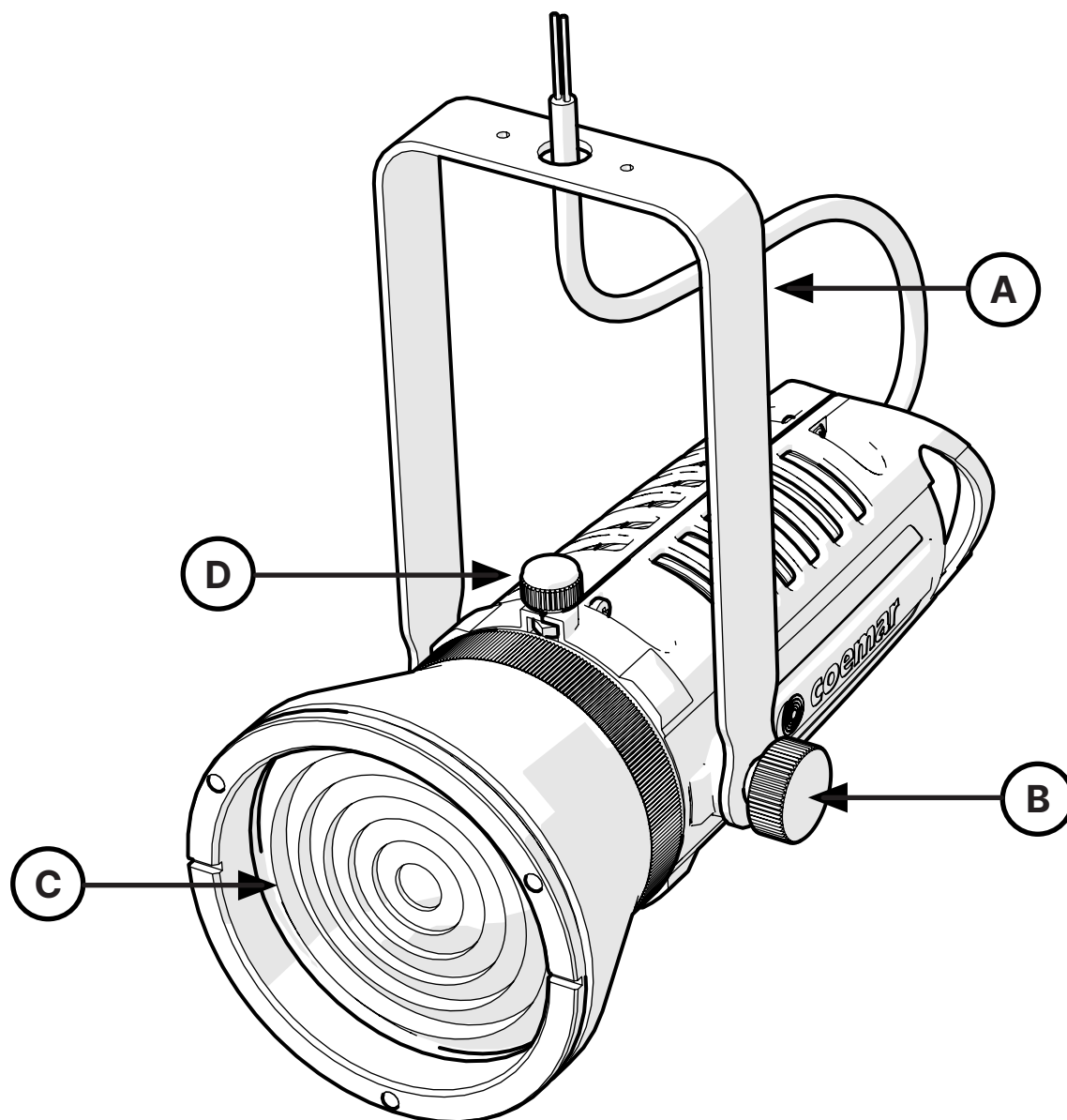

Components description

A	Adjustable yoke
B	Yoke adjusting screws
C	Fresnel Lens
D	Optic Knob

3.10 Unit's main components - MiniLEDko Spot

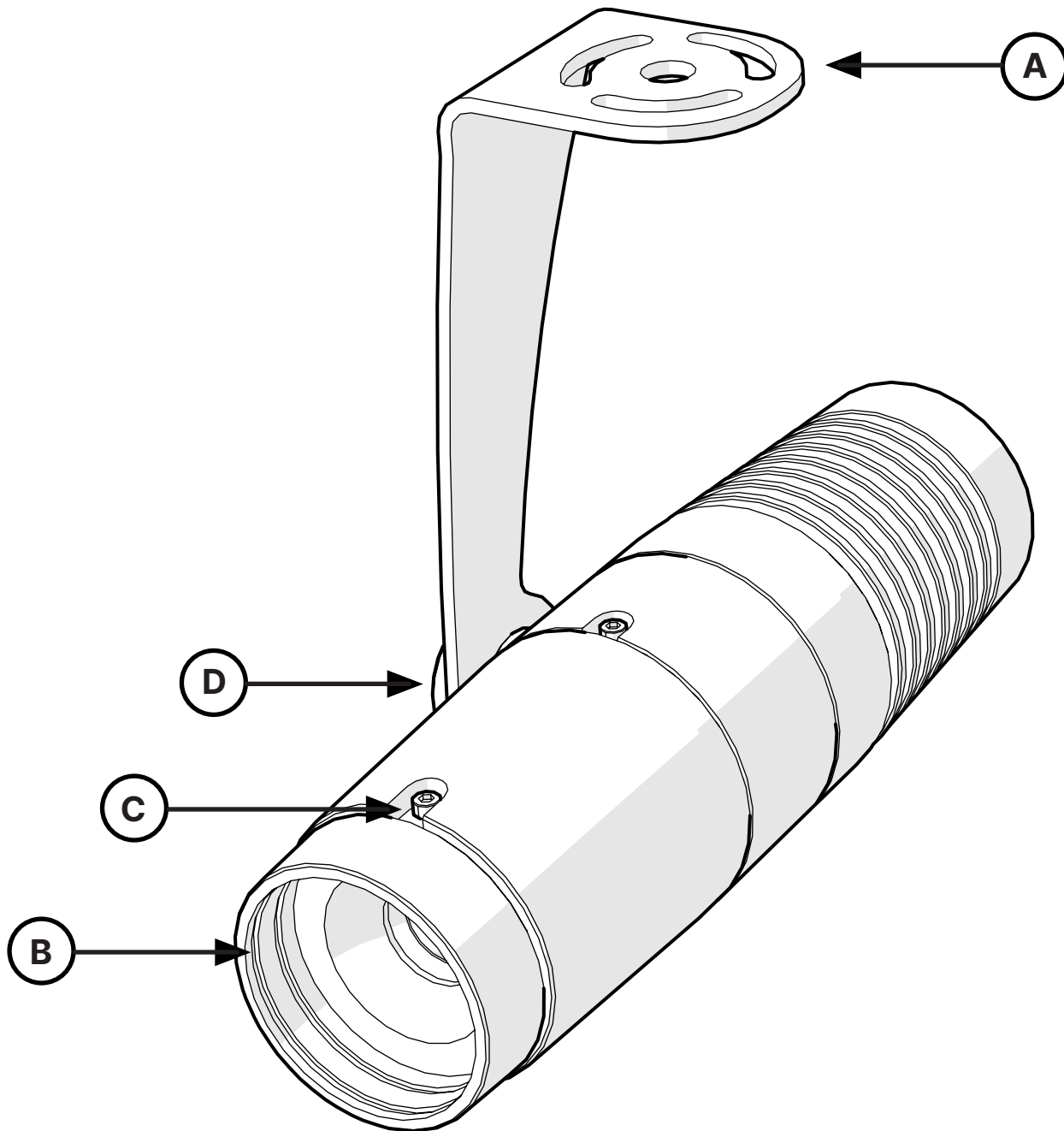

Components description

Components description	
A	Adjustable yoke
B	Lens (interchangeable)
C	Yoke adjusting screws
D	Lens knob

4. Installation

4.1 Mechanical installation

MiniLEDko has three different hanging way: Track, Canopy and Portable.

- **Track:** For use with Track system.
- **Portable:** Includes a C-clamp, and has a permanently installed power cord. Region-specific connectors are available.
- **Canopy:** for wall or ceiling mounting

4.2 Compatible Track System - DALI, DMX versions - Table A

Manufacturer	Type	Model	System
Eutrac	One Track	575 2 1101 575 2 1102 575 2 1103 575 2 1104	3-phase + SIGNAL
Nordic Aluminium	Global Track pulse DALI	XTSC 6x00 XTSCF 6x00 x=1, 2, 3, 4	3-phase + SIGNAL
Powergear	3 Circuits DALI track system	PRO-06X0, 064000 PRO-R6x0, R6400 x=1, 2, 3	3-phase + SIGNAL
Stucchi	One Track Advance	9000A-.../...-ST 9000A-.../...-R	3-phase + SIGNAL
Targetti	Eurostandard Plus	9000A-.../...-ST 9000A-.../...-R	3-phase + SIGNAL

4.3 On/Off, On board potentiometer, Bluetooth App versions - Table B

Manufacturer	Type	Model	System
Eutrac	Surface Track	25-x0 x= 1, 2, 3, 4	3-phase
Ivela	3-phase LKM	7501-x0 x= 1, 2, 3, 4	3-phase
Nordic Aluminium	Global Track Pro	XTS 4x000 x= 1, 2, 3, 4	3-phase
Powergear	3 Circuit Track system	PRO-04x0 x= 1, 2, 3	3-phase

* On/Off, On board potentiometer, Bluetooth App versions products can also be switched on and powered by the tracks indicated in table A, but obviously they cannot be controlled or dimmed via a control signal.

WARNING, note the following safety warnings before installing:

- Use the luminaire in dry locations only, where humidity does not exceed 90 percent (non-condensing).
- Do not mount the luminaire on or near a flammable surface.
- Check that the accessory holder is locked before mounting the luminaire.
- Do not use this luminaire if a lens is deeply scratched or cracked. You must replace a lens when it is damaged.



4.4 Track-mount version installation



WARNING: To reduce the risk of fire and electric shock, use the track-mount luminaire only with the track specified in the table on page 21.



Use the track-mount luminaire with ceiling-mounted track only. This type of track-mounting option is available only with DMX version of MiniLEDko.

1. Insert the DataTrack adapter into the track. The adapter only fits into the track one way with the tabs nesting into the track's groove.
2. Rotate the locking mechanism to lock the adapter into place.
3. Use the circuit selection lock to select the circuit. The desired circuit number should point toward the center of the adapter

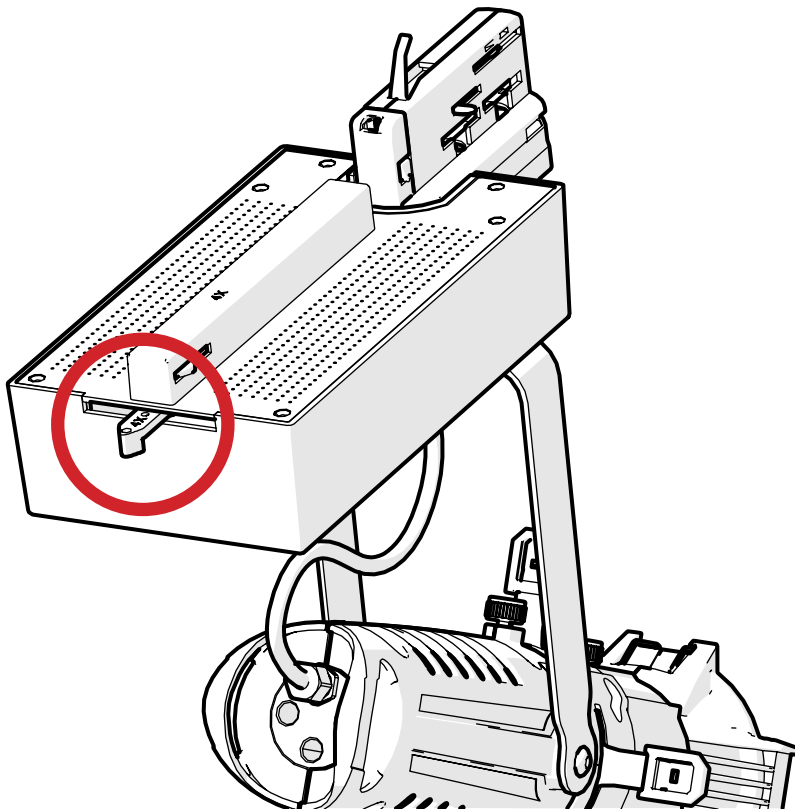

Locking mechanism

(on the back side of the Power Box)

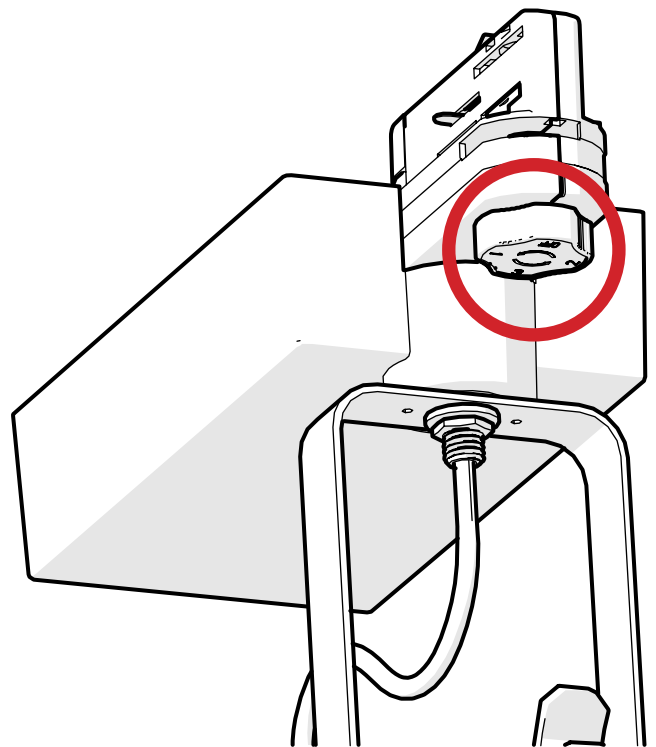

Circuit selection lock

(on the front side of the Power Box)

4.5 Integrated driver Track-mount version installation



This type of track-mounting option is available only with DALI, ON/OFF, potentiometer and Blue-tooth versions of MiniLEDko.

1. Insert the DataTrack adapter into the track. The adapter only fits into the track one way with the tabs nesting into the track's groove.
2. Rotate the locking mechanism to lock the adapter into place (pay attention at the brass connecting slat are inside).
3. Use the circuit selection lock to select the circuit. The desired circuit number should point toward the center of the adapter.
4. *Pay attention, when the potentiometer knob is turned at the minimum the MiniLEDko will **NOT** turn off completely but will remain at a **7% of the maximum luminous output**, if you want to turn it off rotate the circuit selection lock on the "0" or disconnect from the power plug.

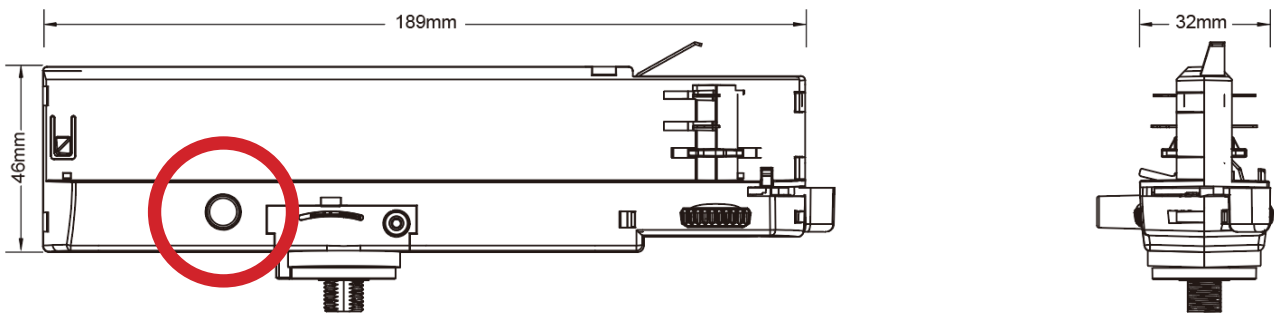

WARNING: When using the circuit selection lock, ensure that the selected circuit is a constant power circuit. Dialing into a dimmable circuit may cause luminaire damage that will void the COEMAR warranty.

*Only for the version with potentiometer on board.

4.6 Portable version installation

MiniLEDko Portable version may be hung from an appropriate structure in any position. If hanging the fixture from a lighting truss or similar, we recommend the use of an appropriate clamp "A", as shown in the following diagram.

Note: use an **M8 screw** to fix the clamp to the MiniLEDko's Power Box

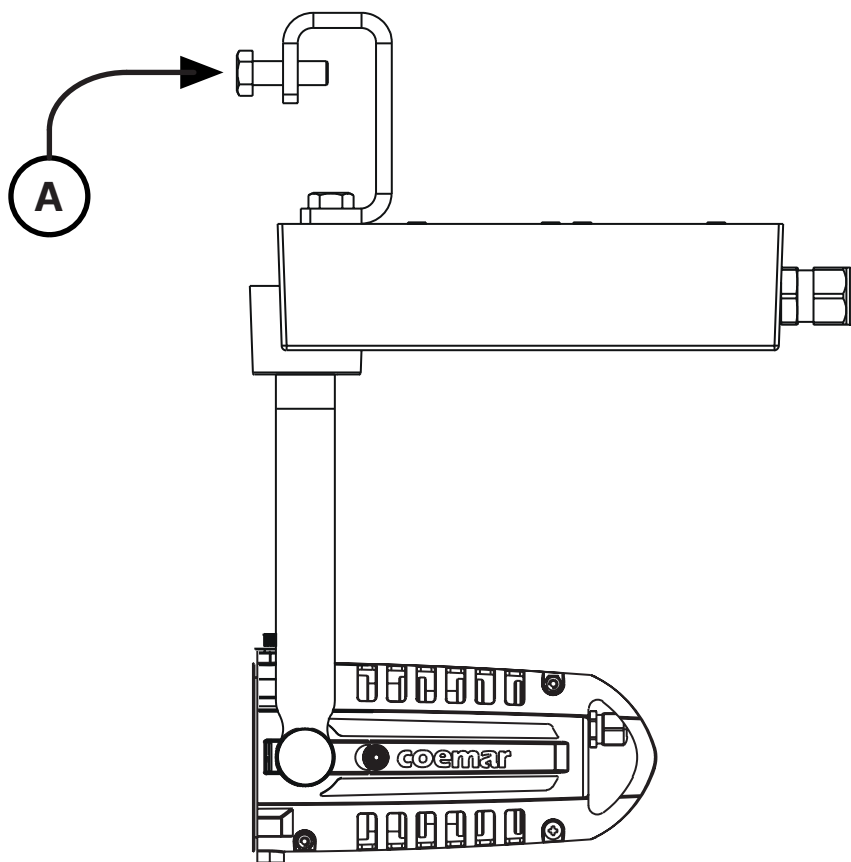

WARNING: Always ensure that your support structure and fixing (bolts, clamps, etc...) are rated A to support the weight of the fixture.

4.7 Canopy version installation

In order to mount a **MiniLEDko Canopy version**, follow the drawing below by attaching first the metal plate "**B**" at the ceiling by using two screws "**C**" and then use the two screws "**D**" to fix the projector to the metal plate.

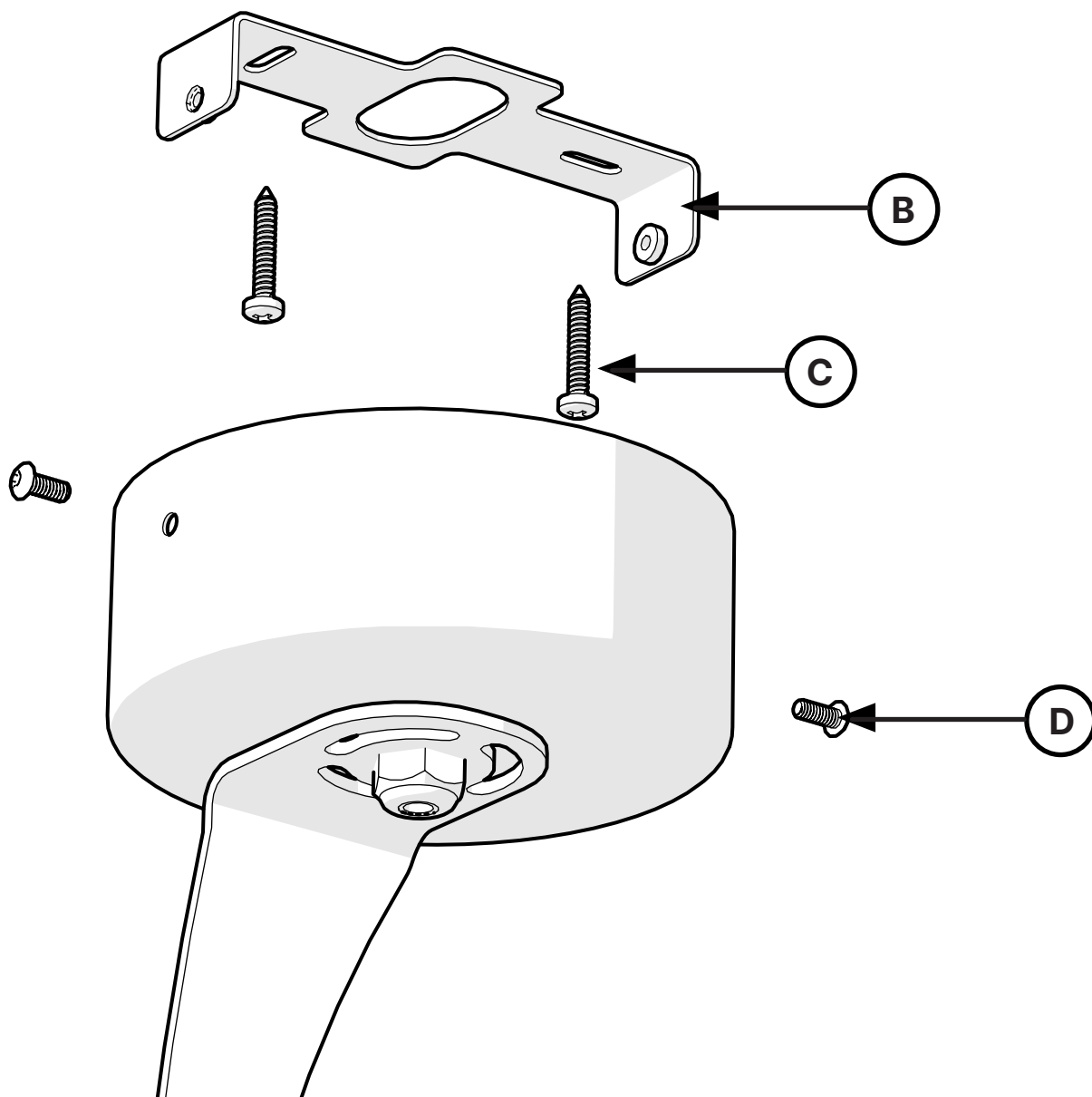

5. MiniLEDko Profile optical adjustments

5.1 Adjusting MiniLEDko Profile and Fresnel's tilt

In order to adjust the tilt of MiniLEDko **Profile** and **Fresnel** simply loose the side knob "A", adjust the tilt and lock the yoke by tightening the screws again.

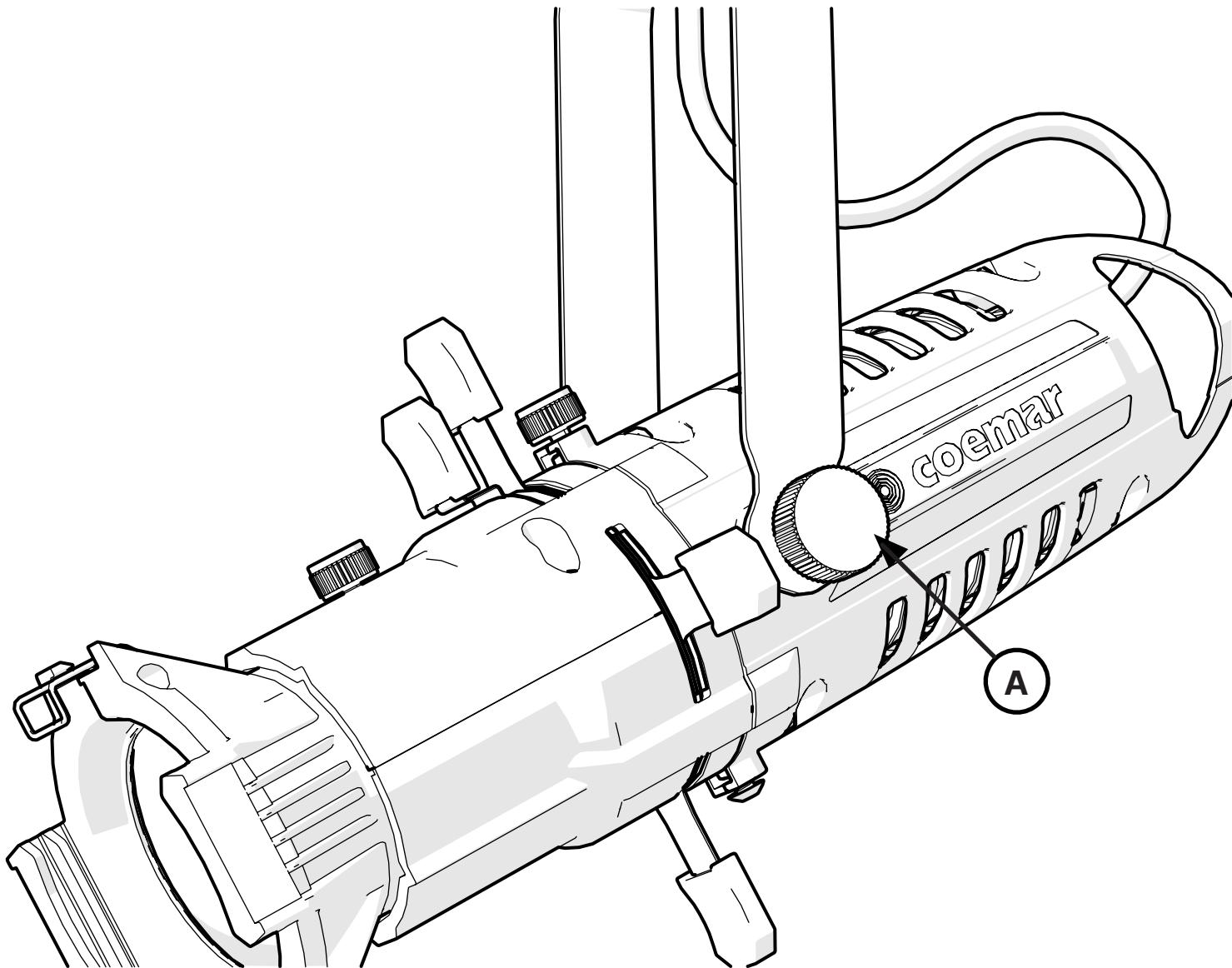

5.2 How to adjust the MiniLEDko Profile's focus

In order to adjust the focus loosen the knob "B" adjust the lens tube, by pulling and pushing, position as needed, and then tighten the knob.

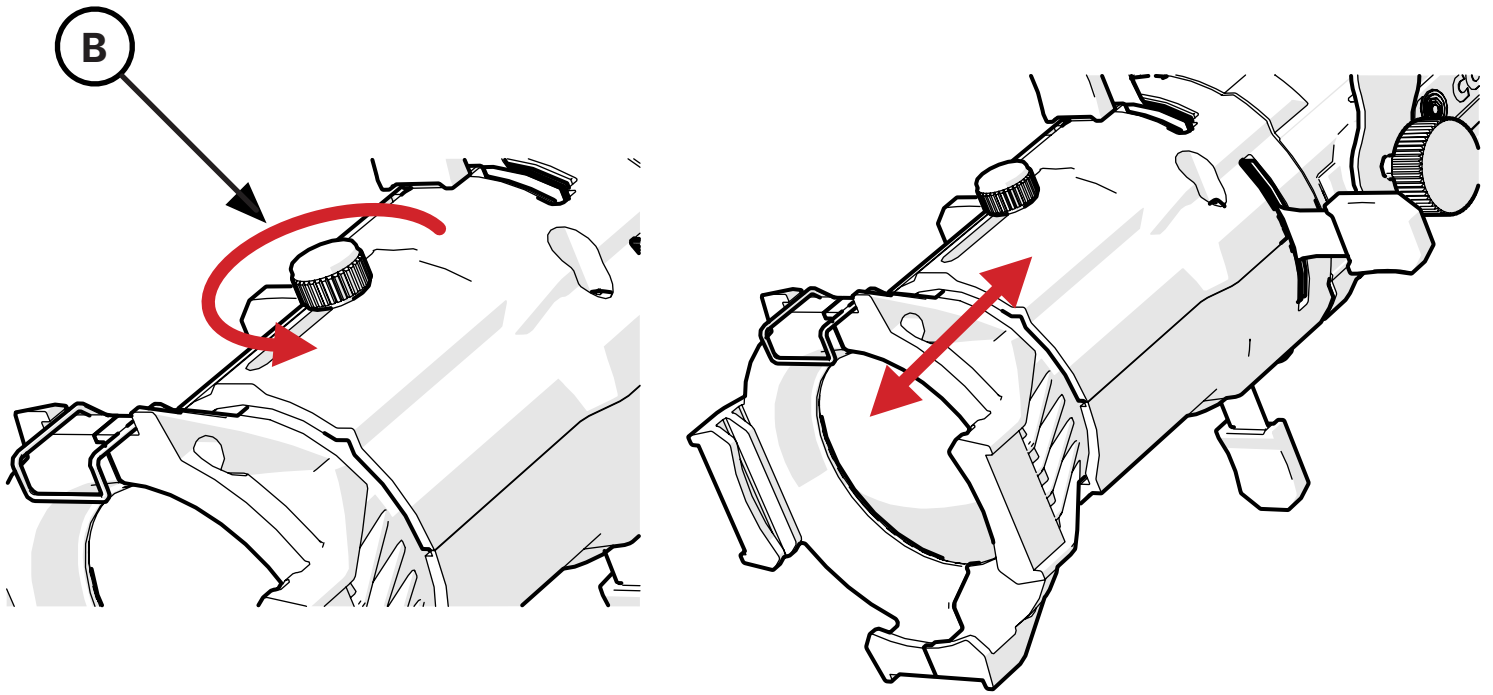

5.3 How to shape the MiniLEDko Profile's Beam with Shutters

The luminaire has four shutters: left, right, top, and bottom. Each shutter can be pulled out or pushed in to create the desired beam shape.

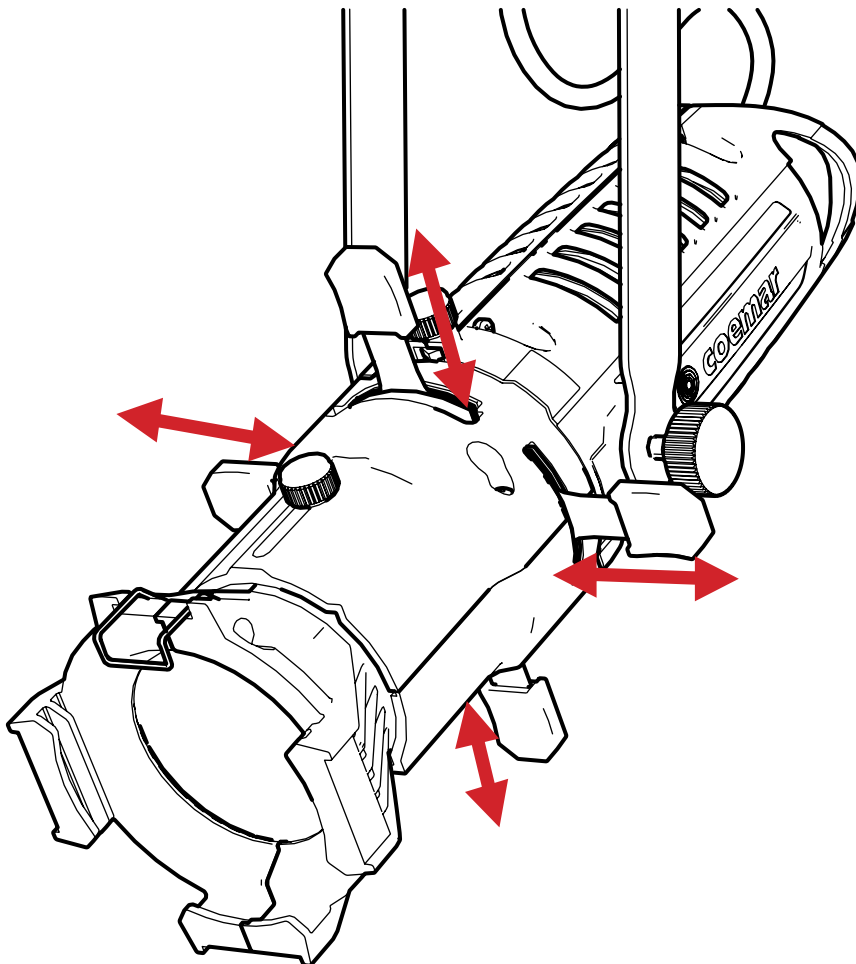

5.4 How to insert a gobo

1. Take your gobo holder, pull away the metal plate (indispensable to prevent the gobo from falling); if a metal gobo is used (therefore very fine), use the metal ring supplied (code 382.020), this process will increase the thickness of the gobo, this will ensure that the gobo does not move inside the gobo holder.

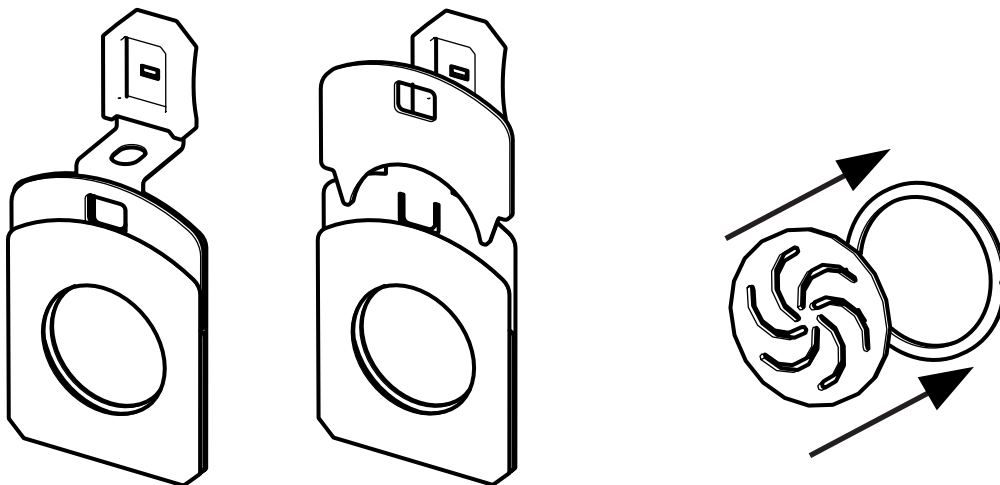

2. Insert the gobo and place back the metal plate.

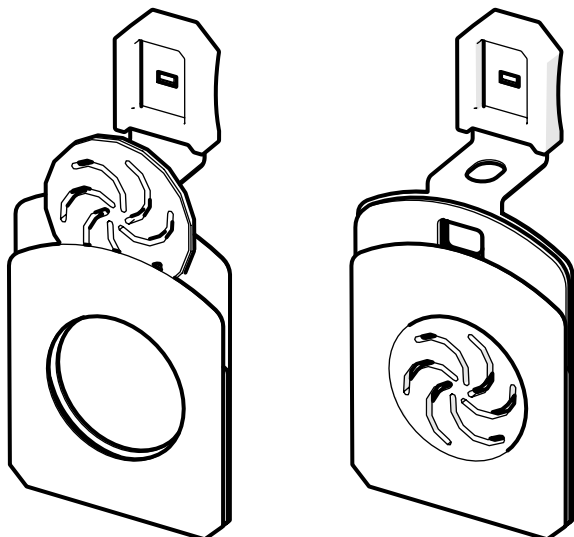

3. In order to prevent the fallen of the gobo apply a force on the back locking tab "I" by using a screwdriver.

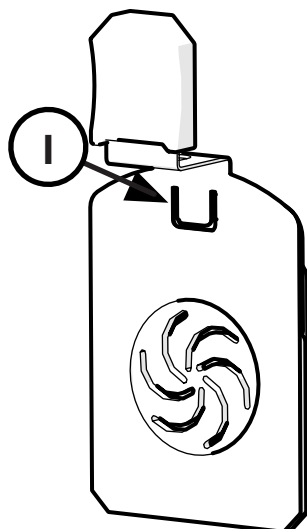

4. Once the closing tube for optical unit is removed and the gobo is inserted, mount the gobo holder into the **MiniLEDko Profile** slot.

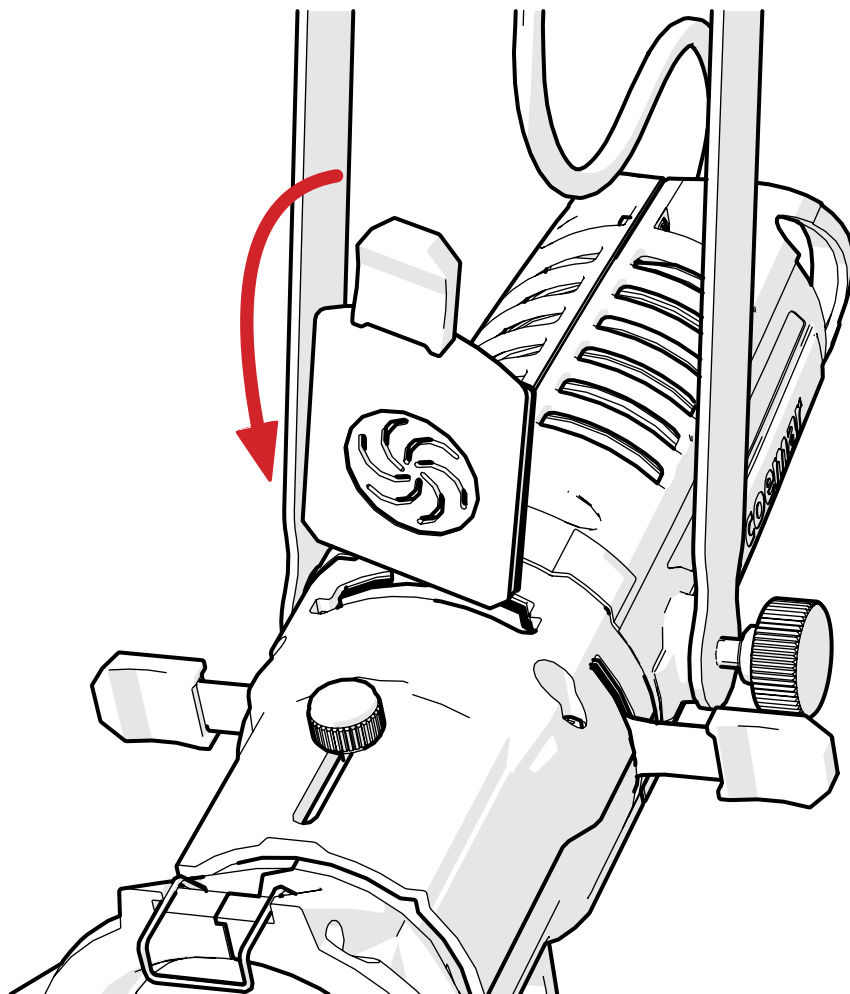

6. MiniLEDko Fresnel optical adjustments

6.1 Adjusting unit's tilt

In order to adjust the tilt of the unit simply loose the side screws "A", adjust the tilt and lock the yoke by tightening the screws again.

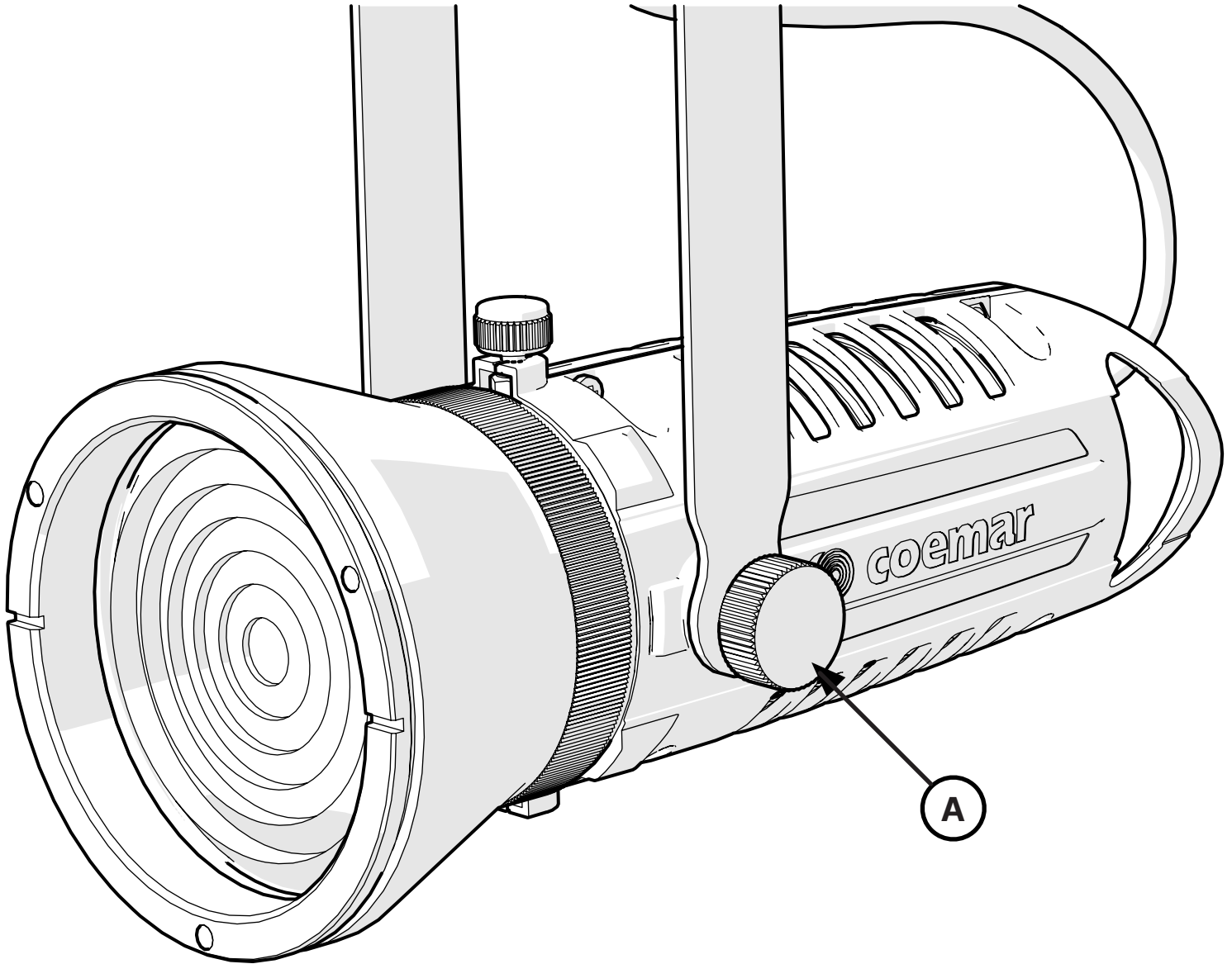

6.2 How to adjust the MiniLEDko Fresnel's Zoom

In order to adjust the zoom loosen the knob "B" turn the optical group until you will obtain the zoom desired, then tighten the knob.

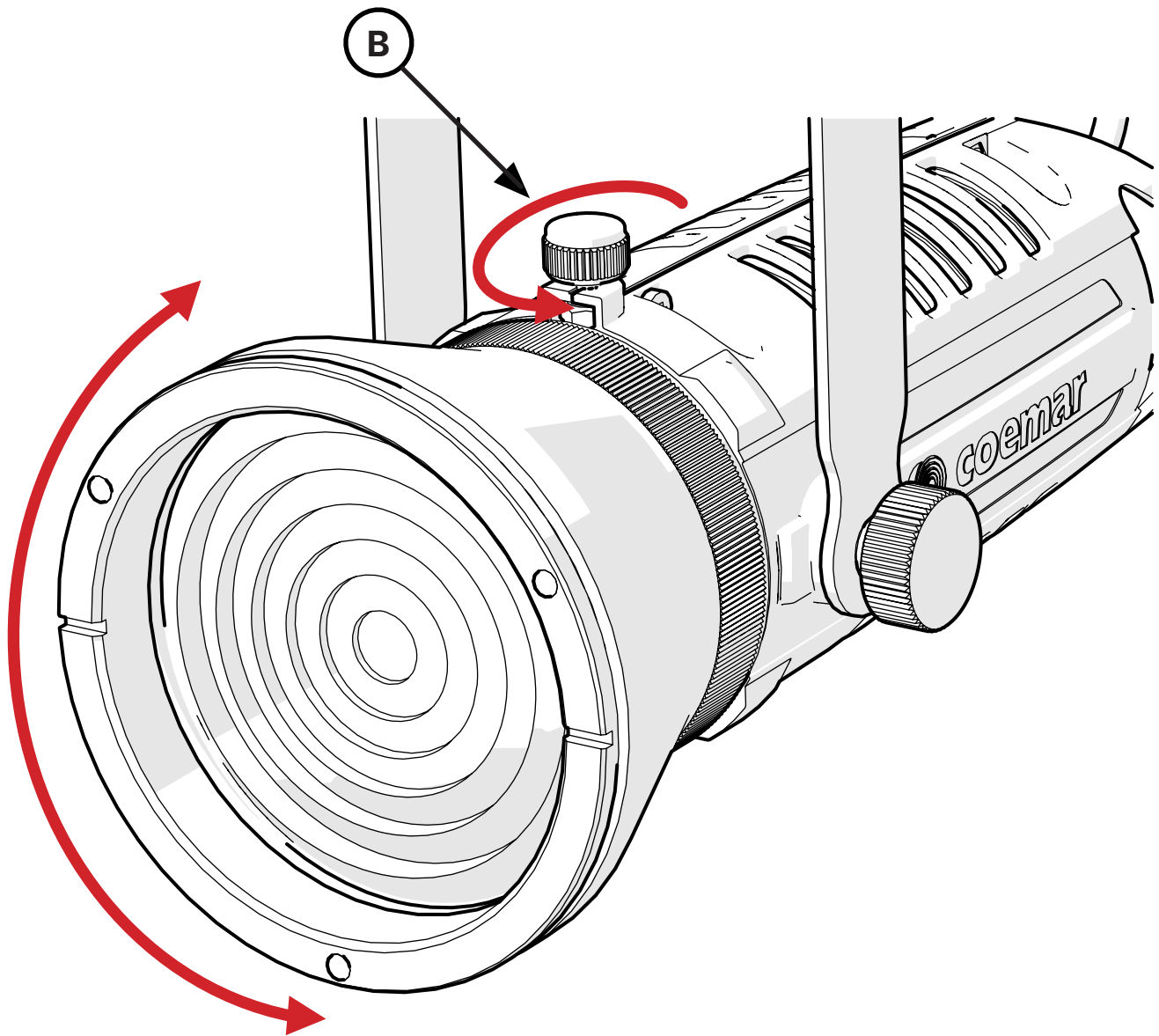

7. MiniLEDko Spot optical adjustments

7.1 Adjusting unit's tilt

In order to adjust the tilt of the unit simply loose the side screws "A", adjust the tilt and lock the yoke by tightening the screws again.

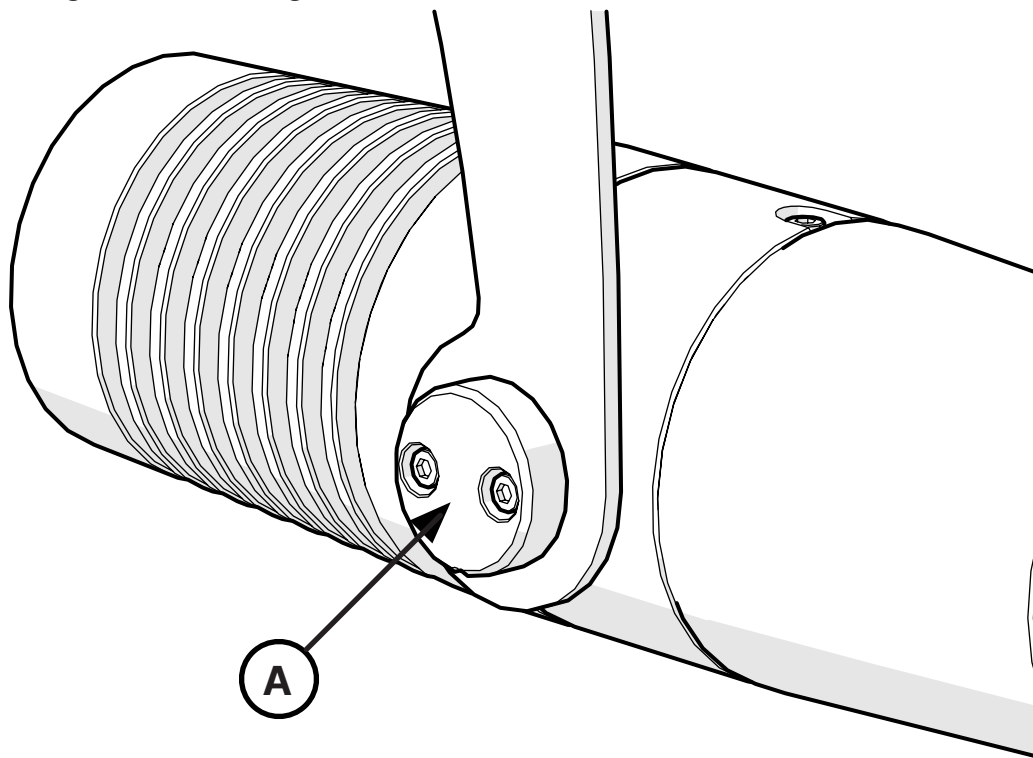

7.2 How to adjust the focus

In order to adjust the focus turn the lens "B" until you will have reached the focus desired.

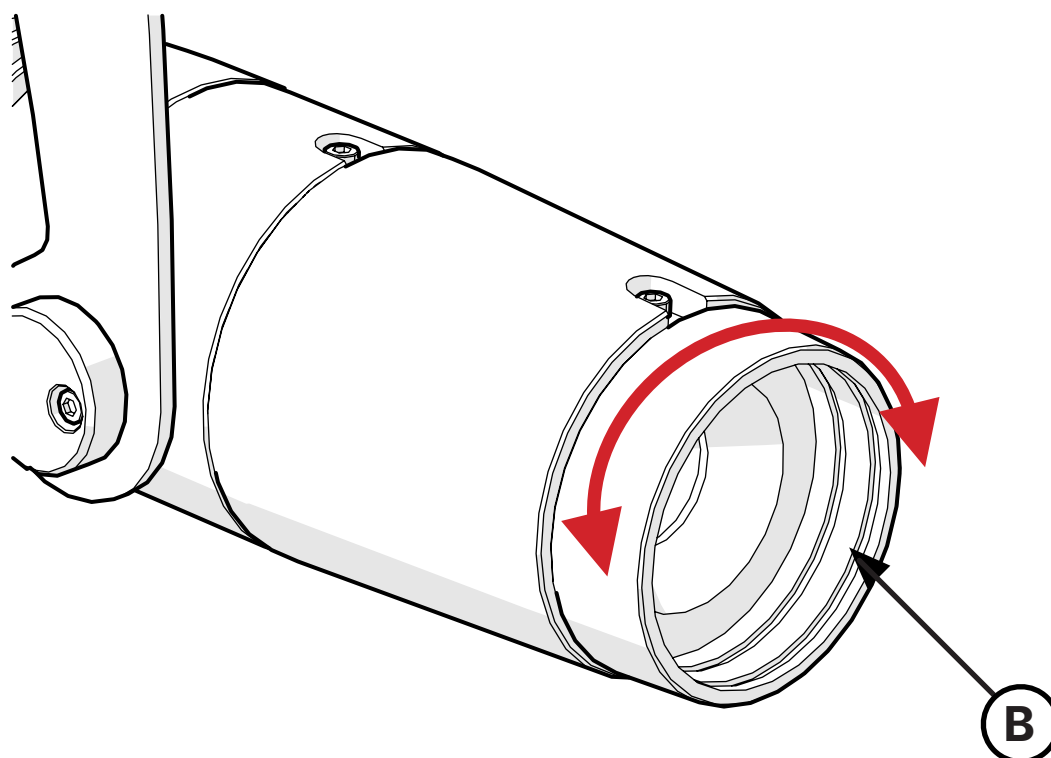

7.3 How to mount the gobo

1. To change the gobo unscrew the screw "C" and pull the optical lens tube "D".

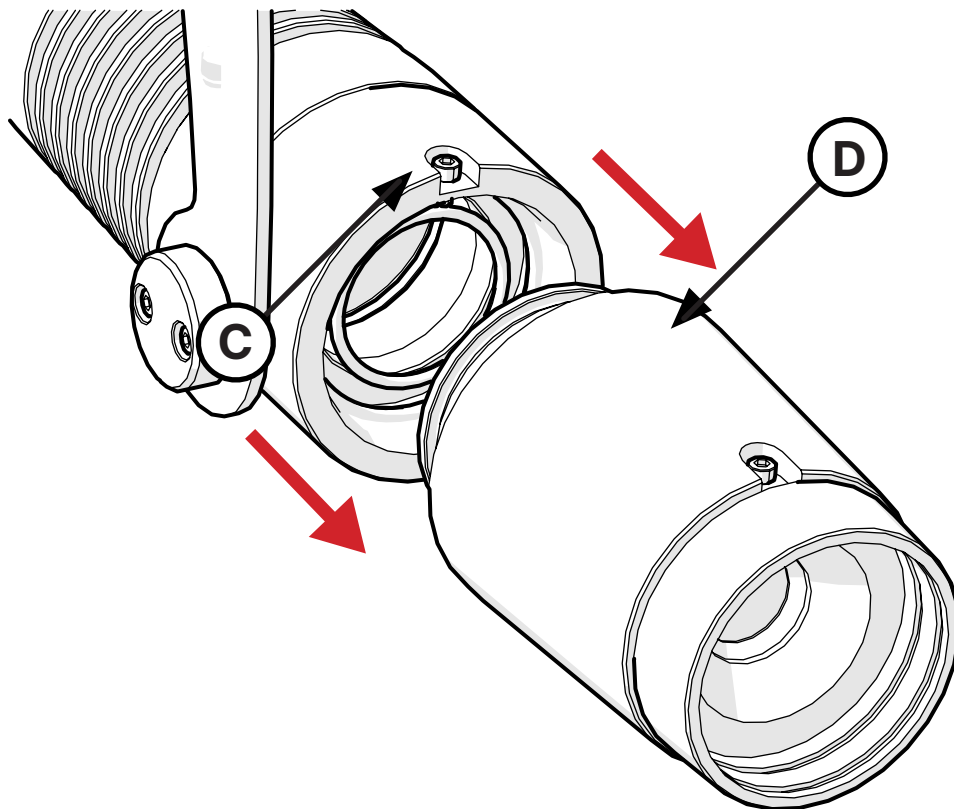

2. Unscrew the gobo stopper "E" by using the included metal key "F" (BC016A010).

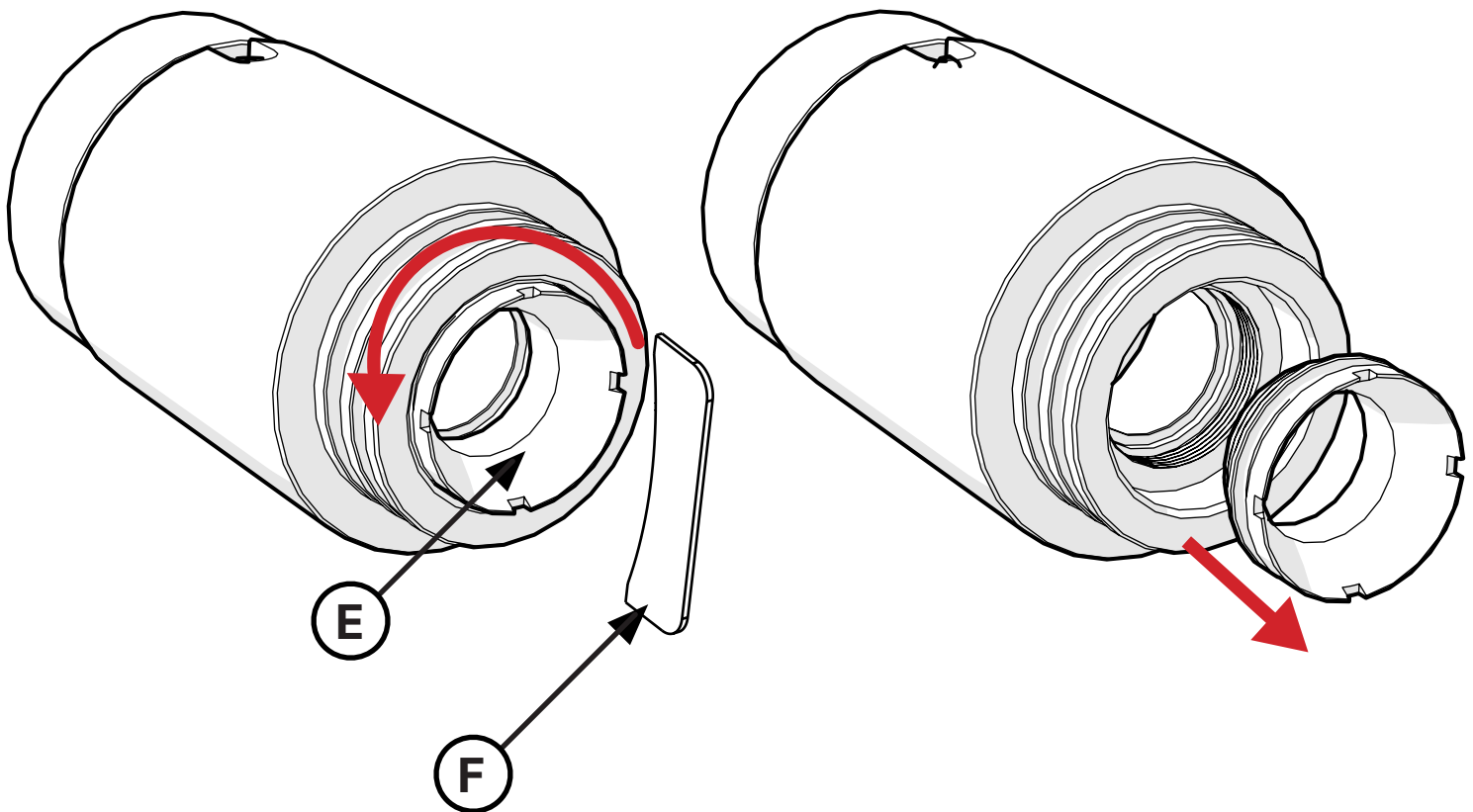

3. Insert the gobo "G" and proceed with the closing of the projector by re-mounting the gobo holder and by pushing again the optical lens tube until it will be perfectly closed, tighten the screw "H".

N.B. the gobo **must comply with the following measures**, otherwise MiniLEDko Spot may not work properly:

Gobo outside diameter= 26 mm / 1.02 in

Max image diameter= 22 mm / 0.86 in

Max Gobo thickness= 2mm / 0.08 in (glass gobo)

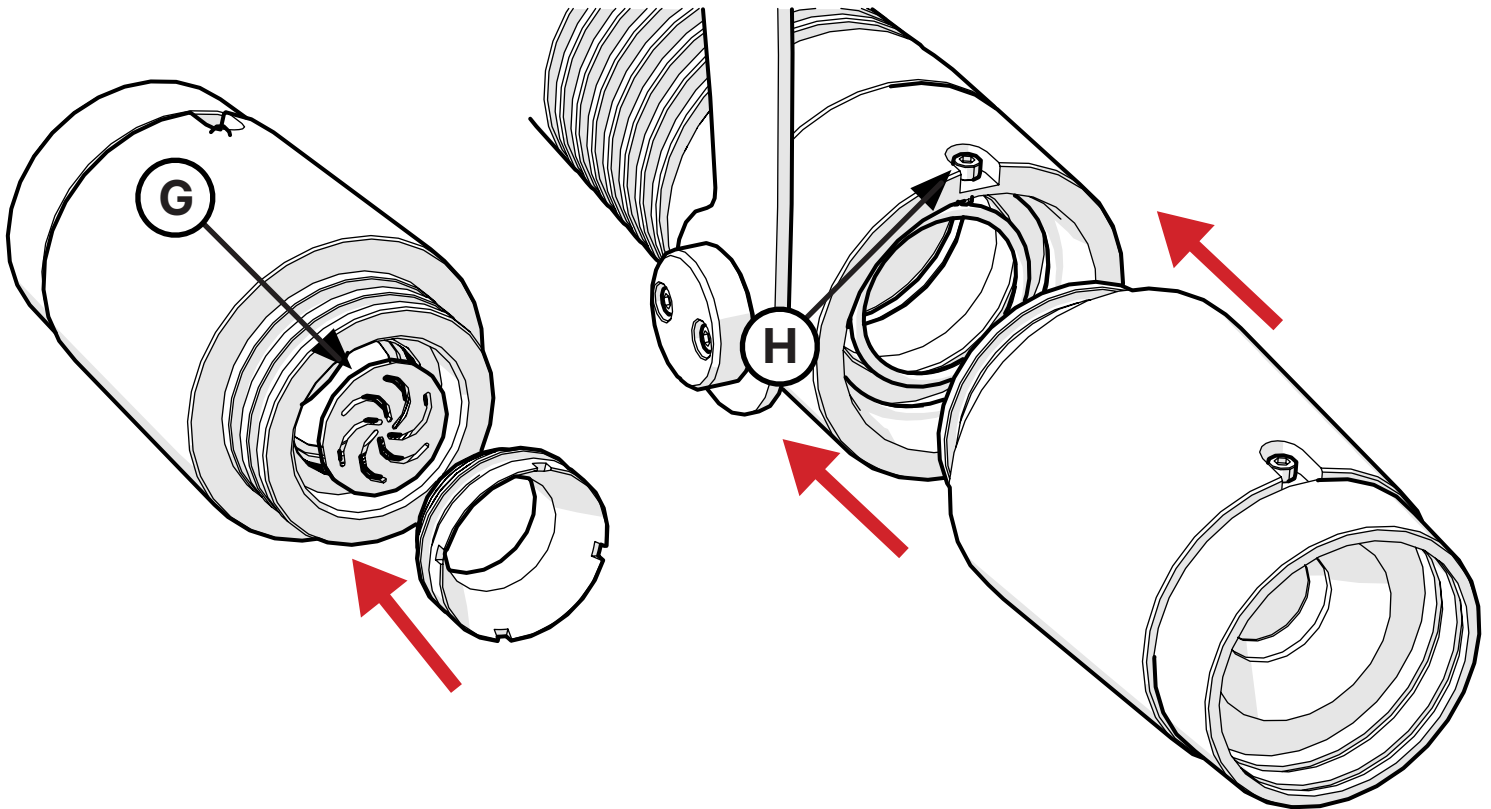

7.4 How to change the optic

1. To change the optic unscrew the screw "I" and the screw underneath the front barrel "J".

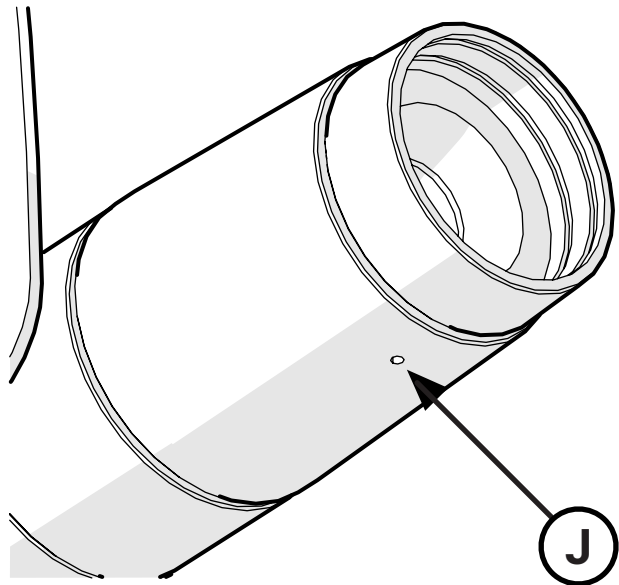
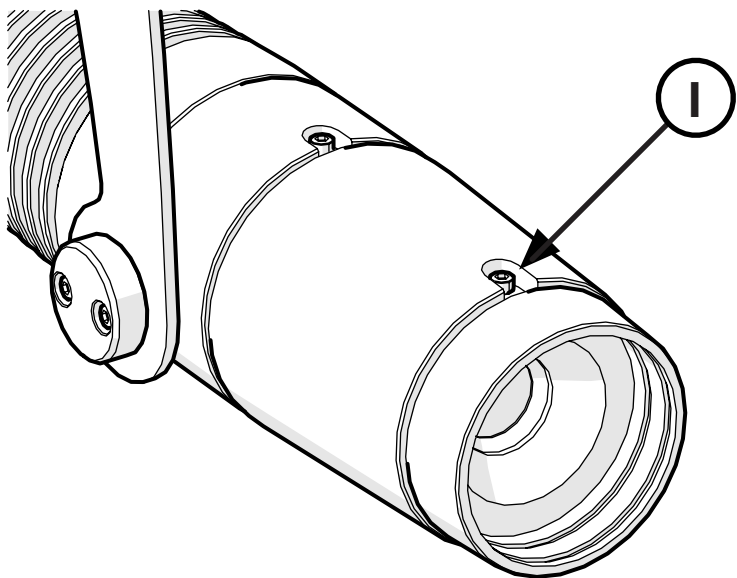

2. Now the optic will come off, chose the optic that you want to use and insert it into the barrel.

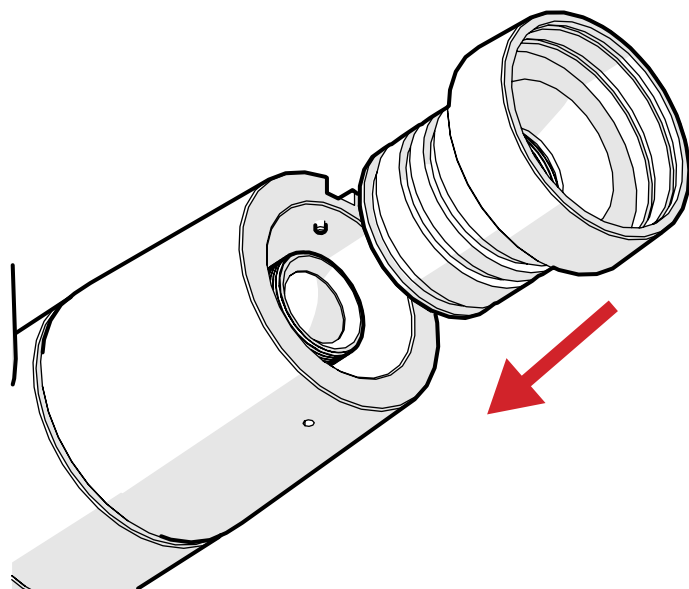
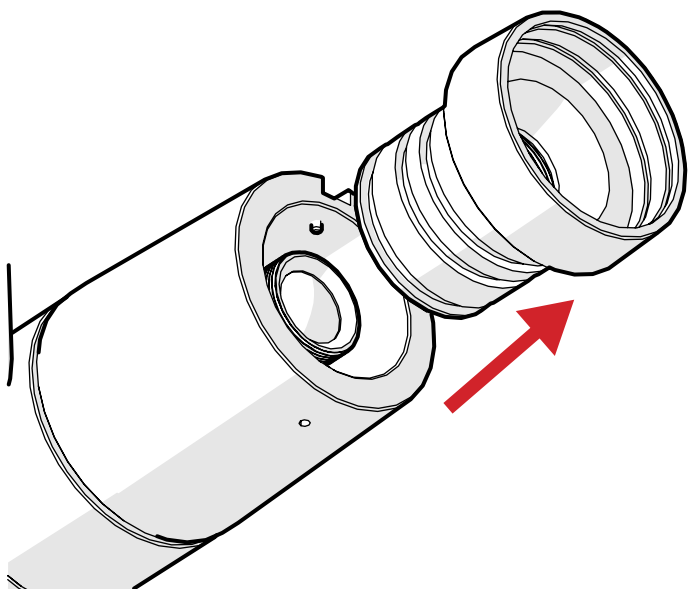

3. Once remounted the optic, tighten the screw underneath the front barrel "K" and the screw on top "L".

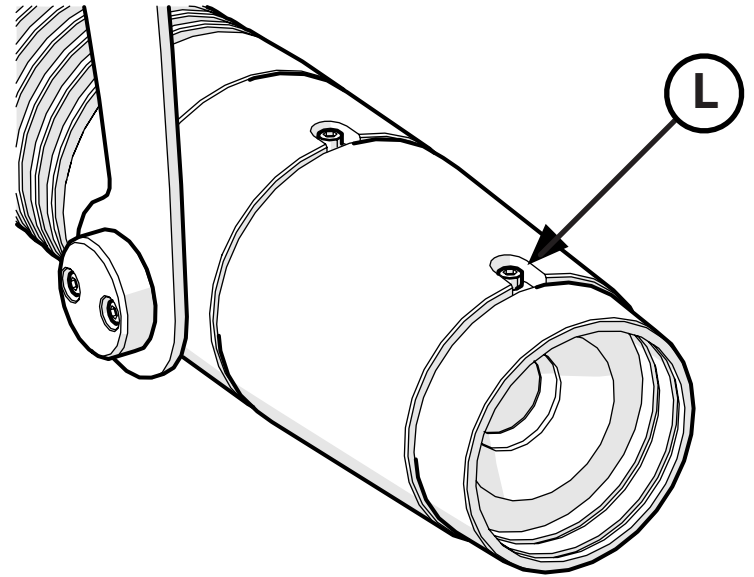
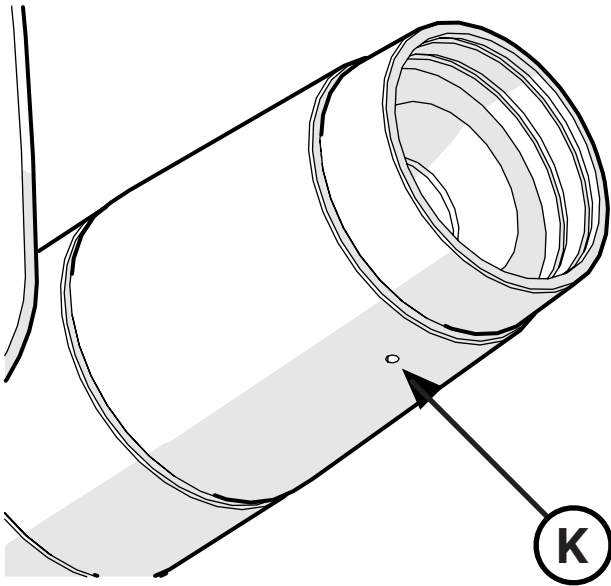

- Pay attention when you tighten the screw "L", proceed by slightly tightening the screw until it reaches the end of the screw stroke without over-tightening, then try moving the optic half a turn, now try tightening the screw again to check that the screw was really at the end of the stroke, if not, complete by tightening the screw.
- Two different front barrels are available, the optics 12° (BC016A000) and 19° (BC016A001) will match the front barrel coded BC016A100, the optic 21° (BC016A002) will match the front barrel coded BC016A110.

8. DMX/DALI Connection

Follow the drawing below in order to properly connect the power head of the track on which the product will be installed.

N.B. in case you need more information about the track you can visit the track producer website. See below for example the connection diagram for track STUCCHI (main track recommended).

WARNING! With tracks comply with DMX/RDM protocol, use termination resistor

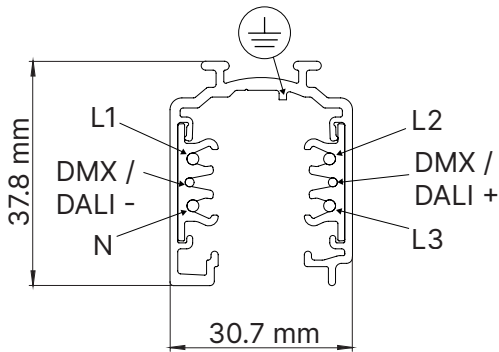

The shielded cable will remain disconnected

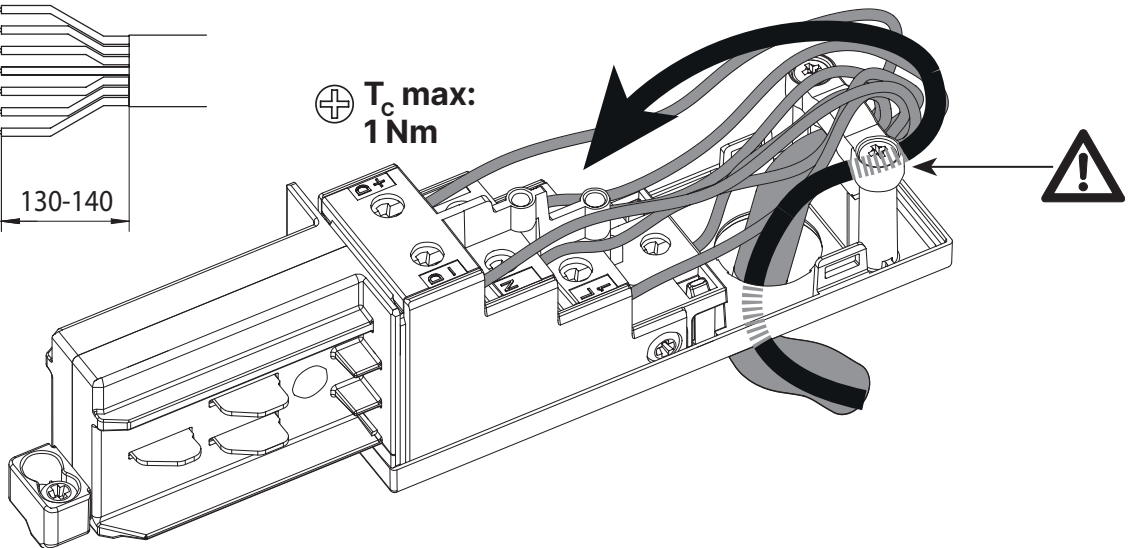
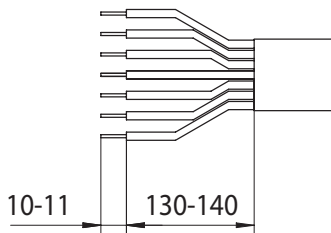
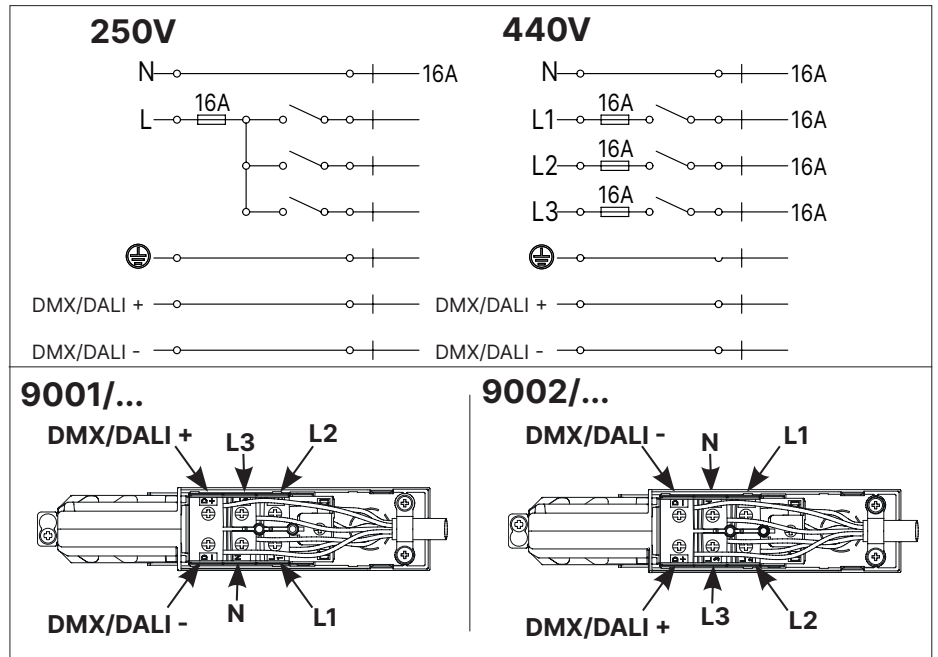

⚠

PLEASE ENSURE THAT THE DATA BUS WIRING DOES NOT CREATE A RING STRUCTURE. A FAILURE-FREE DATA BUS CANNOT BE ENSURED IF ONE IS PRESENT. IF THE TRACK INSTALLATION REQUIRES THE USE OF "L", "T" OR "X" - SHAPED JOINT, IT IS POSSIBLE TO DISCONNECT THE DATA BUS IN THESE JOINTS TO AVOID CREATING A RING STRUCTURES.

9. Setup via RDM

9.1 Quick guide to menu

The **MiniLEDko** required RDM (Remote Device Management) to set up fixtures. Using an RDM compliant DMX controller, you can communicate with all the fixtures on a data link without needing to connect to each fixture individually. RDM lets you set the DMX addresses of all the fixtures on the link, carry out fixture configuration and retrieve fixture data including details of any error that has been logged. If two or more identical fixtures are set up with the same DMX address and in the same DMX mode, they will receive the same instructions and behave identically. Setting up identical fixtures with the same address is a good tool for troubleshooting unexpected behavior and an easy way to achieve synchronized action. Setting DMX addresses via RDM involves running a scan to identify the fixtures that are present on the data link and then allocating addresses either automatically or manually.

To use RDM:

1. Obtain an RDM-compatible controller such as the RDM UPGRADE INTERFACE B (cod. AC10011A001) application running on a Windows PC.
2. Use a USB cable to connect the PC to a USB/DMX interface box
3. Connect the interface box to the data link.
4. Power the fixture on and carry out an RDM discovery / scan in your RDM-compatible controller.
5. You can then configure or retrieve data from the fixtures on the data link.

N.B. The maximum number of products that can be connected when using with RDM is 32 MiniLEDko.

9.2 RDM Chart

PARAMETER	DESCRIPTION
DMX ADDRESS	Set DMX Address: (1-512)
CURVE	Set Dimming Curve: Linear, Logarithmic, Exponential, Halogen, Standard
FREQUENCY	Set Pwm Frequency: 600Hz-1500Hz-2000Hz-5000Hz-20.000Hz
LOCK PIN	Set Lock Pin
LOCK STATE	Set Screen Lock
FACTORY DEFAULT	Factory Reset
PERSONALITY	Set Personality: 5/1 Ch (Fixed White version) 5/2/1/Sunrise/Raw (VariWhite version)
SENSOR	Visualize Sensor
LED HOURS	Visualize Led Life Hours
DEVICE HOURS	Visualize Device Life Hours

9.3 RDM Error Chart

ERROR	DESCRIPTION	SOLUTION
MEMORY	Memory Reading Error	Perform A "Factory Reset"
HW MEMORY	Memory Hardware Error	Contact Coemar
DMX ADDR	DMX Addressing Error	The Personality Dimension Exceeds 512 Channels
NTC ERROR	Temperature Sensor Disconnected	Check Wiring NTC Led
SHORT NTC	Short-Circuited Temperature Sensor	Check Wiring NTC Led
OVER TEMP	Electronic Board Overtemperature	Ambient temperature too high, place the projector in an environment with temperature below 40°C

10. DMX chart - Fixed White version

10.1 DMX modes

DMX channels ↓	5 channels	1 channel
1	Master Dimmer	Master Dimmer
2	Spare Channel	
3	Dimmer Fine	
4	Strobe	
5	Special Function	

10.2 DMX Chart 5/1 channels

channel		function	type of control	effect	decimal	percentage
1	1	master dimmer	proportional	adjust luminous output intensity from 0 to 100%	0 - 255	0% - 100%
2	-	spare channel	step	no effect	0 - 255	0% - 100%
3	-	dimmer fine	proportional	fine dimmer control 16 bit	0 - 255	0% - 100%
4	-	strobe	step	no effect	0 - 9	0% - 4%
			proportional	variable speed strobing effect, from slow to fast	10 - 57	4% - 22%
			step	stop strobe	58 - 59	23% - 23%
			proportional	sequenced pulse effect, slow closing, fast opening (variable speed pulsing, from slow to fast)	60 - 108	24% - 42%
			step	stop strobe	109 - 110	43% - 43%
			proportional	sequenced pulse effect, fast closing, slow opening (variable speed pulsing, from slow to fast)	111 - 159	44% - 62%
			step	stop strobe	160 - 161	63% - 63%
			proportional	random strobe effect with variable speed from slow to fast	162 - 207	64% - 81%
			step	stop strobe	208 - 209	82% - 82%
			proportional	random strobe effect with variable speed from slow to fast	210 - 255	82% - 100%
5	-	special functions	step	park	0 - 9	0% - 4%
				600 Hz	10 - 22	4% - 9%
				no effect	23 - 199	9% - 78%
				LED control frequency tuning 1.500 Hz	200 - 205	78% - 80%
				LED control frequency tuning 2.000 Hz	206 - 211	81% - 83%
				LED control frequency tuning 5.000 Hz	212 - 217	83% - 85%
				no effect	218 - 240	85% - 94%
				LED control frequency tuning 20.000 Hz	241 - 255	95% - 100%

11. DMX chart - VariWhite version

11.1 DMX modes

DMX channels ↓	5 channels	2 channels	1 channel	Sunrise mode	Raw mode	2 (MK1) channels	6 channels
1	Master Dimmer	Master Dimmer	Master Dimmer	Master Dimmer	Warm White Led	Master Dimmer	Master Dimmer
2	Dimmer Fine	White Tone		Dimmer Fine	Warm White Led Fine	White Tone	Dimmer Fine
3	White Tone			Proportional White Tone	Cold White Led		White Tone
4	Strobe Effect			Step White Tone	Cold White Led Fine		White Temperature Fine
5	Special Function			Special Function			Strobe Effect
6							Special Function

11.2 DMX Chart 5 channels

channel	function	type of control	effect	decimal	percentage
1	master dimmer	proportional	adjust luminous output intensity from 0 to 100%	0 - 255	0% - 100%
2	dimmer fine	proportional	fine dimmer control 16 bit	0 - 255	0% - 100%
3	white tone	step	2.700 K	0 - 6	0% - 2%
		proportional	proportional value from 2.700 K to 3.200 K	7 - 33	3% - 13%
		step	3.200 K	34 - 60	13% - 24%
		proportional	proportional value from 3.200 K to 4.000 K	61 - 87	24% - 34%
		step	4.000 K	88 - 114	35% - 45%
		proportional	proportional value from 4.000 K to 5.000 K	115 - 141	45% - 55%
		step	5.000 K	142 - 168	56% - 66%
		proportional	proportional value from 5.000 K to 5.600 K	169 - 195	66% - 76%
		step	5.600 K	196 - 222	77% - 87%
		proportional	proportional value from 5.600 K to 6.500 K	223 - 249	87% - 98%
step	6.500 K	250 - 255	98% - 100%		
4	strobe effect	step	no effect	0 - 9	0% - 4%
		proportional	variable speed strobing effect, from slow to fast	10 - 57	4% - 22%
		step	stop strobe	58 - 59	23% - 23%
		proportional	sequenced pulse effect, slow closing, fast opening (variable speed pulsing, from slow to fast)	60 - 108	24% - 42%
		step	stop strobe	109 - 110	43% - 43%
		proportional	sequenced pulse effect, fast closing, slow opening (variable speed pulsing, from slow to fast)	111 - 159	44% - 62%
		step	stop strobe	160 - 161	63% - 63%
		proportional	random strobe effect with variable speed from slow to fast	162 - 207	64% - 81%
		step	stop strobe	208 - 209	82% - 82%
		proportional	random strobe effect with variable speed from slow to fast	210 - 255	82% - 100%
5	special functions	step	park	0 - 9	0% - 4%
			600 Hz	10 - 22	4% - 9%
			no effect	23 - 199	9% - 78%
			LED control frequency tuning 1.500 Hz	200 - 205	78% - 80%
			LED control frequency tuning 2.000 Hz	206 - 211	81% - 83%
			LED control frequency tuning 5.000 Hz	212 - 217	83% - 85%
			no effect	218 - 240	85% - 94%
			LED control frequency tuning 20.000 Hz	241 - 255	95% - 100%

11.3 DMX Chart 2 / 1 channels

channel	function	type of control	effect	decimal	percentage
1	1	master dimmer	proportional	adjust luminous output intensity from 0 to 100%	0 - 255 0% - 100%
2	-	white tone	proportional	proportional value from 2.700 K to 6.500 K	0 - 255 0% - 100%

11.4 DMX Chart Sunrise mode

channel	function	type of control	effect	decimal	percentage
1	master dimmer	proportional	adjust luminous output intensity from 0 to 100%	0 - 255	0% - 100%
2	dimmer fine	proportional	fine dimmer control 16 bit	0 - 255	0% - 100%
3	proportional white tone	proportional	2.700 K	0	0%
			proportional value from 2.700 K to 4.000 K	1 - 86	0% - 34%
			4.000 K	87	34%
			proportional value from 4.000 K to 5.000 K	88 - 152	35% - 60%
			5.000 K	153	60%
			proportional value from 5.000 K to 5.600 K	154 - 192	60% - 75%
			5.600 K	193	76%
			proportional value from 5.600 K to 6.500 K	194 - 254	76% - 100%
6.500 K	255	100%			
4	step white tone	step	no effect	0 - 9	0% - 4%
			2.700 K	10 - 50	4% - 20%
			3.200K	51 - 91	20% - 36%
			4.000K	92 - 132	36% - 52%
			5.000K	133 - 173	52% - 68%
			5.600K	174 - 213	68% - 84%
			6.500K	214 - 255	84% - 100%
5	special functions	step	park	0 - 9	0% - 4%
			600 Hz	10 - 22	4% - 9%
			no effect	23 - 199	9% - 78%
			LED control frequency tuning 1.500 Hz	200 - 205	78% - 80%
			LED control frequency tuning 2.000 Hz	206 - 211	81% - 83%
			LED control frequency tuning 5.000 Hz	212 - 217	83% - 85%
			no effect	218 - 240	85% - 94%
			LED control frequency tuning 20.000 Hz	241 - 255	95% - 100%

Note 1: If channels 3 and 4 are used simultaneously, channel 4 prevails.

11.5 DMX Chart Raw mode

channel	function	type of control	effect	decimal		percentage	
1	warm white led	proportional	adjust luminous output intensity of warm white led from 0 to 100%	0	- 255	0%	- 100%
2	warm white led fine	proportional	warm white led fine control 16 bit	0	- 255	0%	- 100%
3	cold white led	proportional	adjust luminous output intensity of cold white led from 0 to 100%	0	- 255	0%	- 100%
4	cold white led fine	proportional	cold white led fine control 16 bit	0	- 255	0%	- 100%

11.6 DMX Chart 2 channels (MK1)

channel	function	type of control	effect	decimal	percentage
1	master dimmer	proportional	adjust luminous output intensity from 0 to 100%	0 - 255	0% - 100%
2	white tone	step	3200 K	0 - 10	0% - 4%
			2700 K	11 - 16	4% - 6%
			2800 K	17 - 22	7% - 9%
			2900 K	23 - 28	9% - 11%
			3000 K	29 - 34	11% - 13%
			3100 K	35 - 40	14% - 16%
			3200 K	41 - 46	16% - 18%
			3300 K	47 - 52	18% - 20%
			3400 K	53 - 58	21% - 23%
			3500 K	59 - 64	23% - 25%
			3600 K	65 - 70	25% - 27%
			3700 K	71 - 76	28% - 30%
			3800 K	77 - 82	30% - 32%
			3900 K	83 - 88	33% - 35%
			4000 K	89 - 94	35% - 37%
			4100 K	95 - 100	37% - 39%
			4200 K	101 - 106	40% - 42%
			4300 K	107 - 112	42% - 44%
			4400 K	113 - 118	44% - 46%
			4500 K	119 - 124	47% - 49%
			4600 K	125 - 130	49% - 51%
			4700 K	131 - 136	51% - 53%
			4800 K	137 - 142	54% - 56%
			4900 K	143 - 148	56% - 58%
			5000 K	149 - 154	58% - 60%
			5100 K	155 - 160	61% - 63%
			5200 K	161 - 166	63% - 65%
5300 K	167 - 172	65% - 67%			
5400 K	173 - 178	68% - 70%			
5500 K	179 - 184	70% - 72%			
5600 K	185 - 190	73% - 75%			
5700 K	191 - 196	75% - 77%			
5800 K	197 - 202	77% - 79%			
5900 K	203 - 208	80% - 82%			
6000 K	209 - 214	82% - 84%			
6100 K	215 - 220	84% - 86%			
6200 K	221 - 226	87% - 89%			
6300 K	227 - 232	89% - 91%			
6400 K	233 - 238	91% - 93%			
6500 K	239 - 244	94% - 96%			
5600 K	245 - 255	96% - 100%			

11.7 DMX Chart 6 channels

channel	function	type of control	effect	decimal	percentage
1	master dimmer	proportional	adjust luminous output intensity from 0 to 100%	0 - 255	0% - 100%
2	dimmer fine	proportional	fine dimmer control 16 bit	0 - 255	0% - 100%
3	white tone	step	3200 K	0 - 10	0% - 4%
			2700 K	11 - 16	4% - 6%
			2800 K	17 - 22	7% - 9%
			2900 K	23 - 28	9% - 11%
			3000 K	29 - 34	11% - 13%
			3100 K	35 - 40	14% - 16%
			3200 K	41 - 46	16% - 18%
			3300 K	47 - 52	18% - 20%
			3400 K	53 - 58	21% - 23%
			3500 K	59 - 64	23% - 25%
			3600 K	65 - 70	25% - 27%
			3700 K	71 - 76	28% - 30%
			3800 K	77 - 82	30% - 32%
			3900 K	83 - 88	33% - 35%
			4000 K	89 - 94	35% - 37%
			4100 K	95 - 100	37% - 39%
			4200 K	101 - 106	40% - 42%
			4300 K	107 - 112	42% - 44%
			4400 K	113 - 118	44% - 46%
			4500 K	119 - 124	47% - 49%
			4600 K	125 - 130	49% - 51%
			4700 K	131 - 136	51% - 53%
			4800 K	137 - 142	54% - 56%
			4900 K	143 - 148	56% - 58%
			5000 K	149 - 154	58% - 60%
			5100 K	155 - 160	61% - 63%
			5200 K	161 - 166	63% - 65%
			5300 K	167 - 172	65% - 67%
5400 K	173 - 178	68% - 70%			
5500 K	179 - 184	70% - 72%			
5600 K	185 - 190	73% - 75%			
5700 K	191 - 196	75% - 77%			
5800 K	197 - 202	77% - 79%			
5900 K	203 - 208	80% - 82%			
6000 K	209 - 214	82% - 84%			
6100 K	215 - 220	84% - 86%			
6200 K	221 - 226	87% - 89%			
6300 K	227 - 232	89% - 91%			
6400 K	233 - 238	91% - 93%			
6500 K	239 - 244	94% - 96%			
5600 K	245 - 255	96% - 100%			

4	white temperature fine	step	no effect	0		0%	
		proportional	fine white temperature control (from temperature selected to the previous step)	1	- 126	1%	- 49%
		step	no effect	127	- 128	50%	- 50%
		proportional	fine white temperature control (from temperature selected to the following step)	129	- 254	51%	- 99%
		step	no effect	255		100%	
5	strobe effect	step	no effect	0	- 9	0%	- 4%
		proportional	variable speed strobing effect, from slow to fast	10	- 57	4%	- 22%
		step	stop strobe	58	- 59	23%	- 23%
		proportional	sequenced pulse effect, slow closing, fast opening (variable speed pulsing, from slow to fast)	60	- 108	24%	- 42%
		step	stop strobe	109	- 110	43%	- 43%
		proportional	sequenced pulse effect, fast closing, slow opening (variable speed pulsing, from slow to fast)	111	- 159	44%	- 62%
		step	stop strobe	160	- 161	63%	- 63%
		proportional	random strobe effect with variable speed from slow to fast	162	- 207	64%	- 81%
		step	stop strobe	208	- 209	82%	- 82%
		proportional	random strobe effect with variable speed from slow to fast	210	- 255	82%	- 100%
6 ¹	special functions	step	park	0	- 9	0%	- 4%
			600 Hz	10	- 22	4%	- 9%
			no effect	23	- 199	9%	- 78%
			LED control frequency tuning 1.500 Hz	200	- 205	78%	- 80%
			LED control frequency tuning 2.000 Hz	206	- 211	81%	- 83%
			LED control frequency tuning 5.000 Hz	212	- 217	83%	- 85%
			no effect	218	- 240	85%	- 94%
			LED control frequency tuning 20.000 Hz	241	- 255	95%	- 100%

Note 1: **SPECIAL FUNCTIONS** channel is not compatible with **MK1 VERSION**

12. Connect and use a MiniLEDko via Bluetooth

Download the BLL Plus App via the store on your Smartphone. Then launch the App.

1.

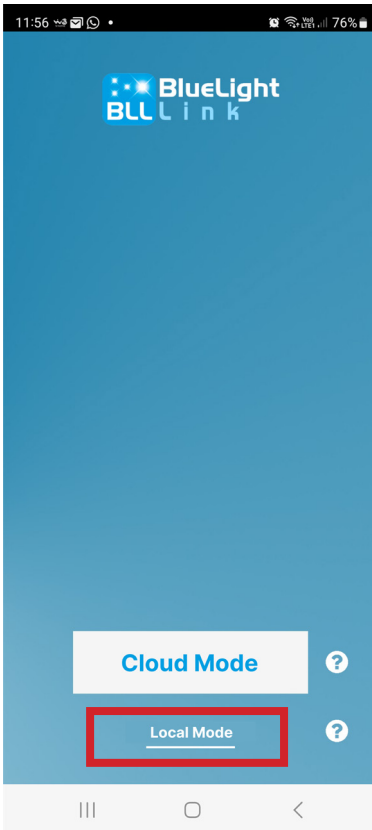

Click on “**Local Mode**”.

2.



Name the **Network** as you please.

3.

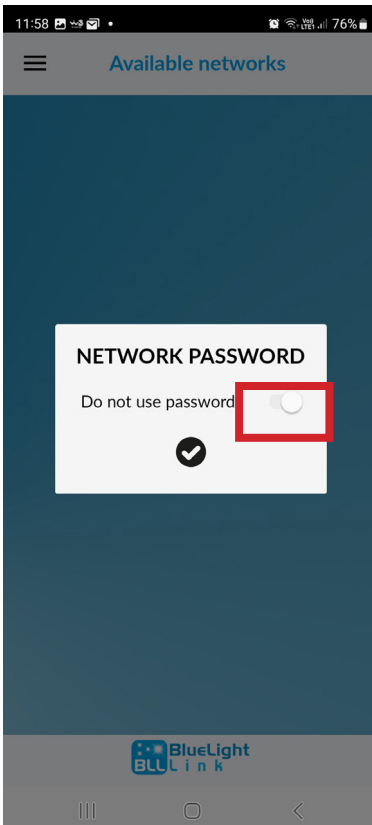

Now decide if you want to protect your projectors, by using a **password** and to do this, flip the switch.

4.



Select the menu with three dashes in the upper left.

5.

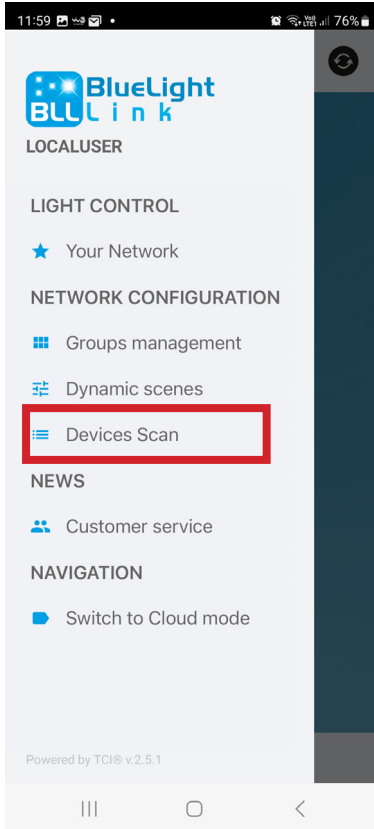

Select “Scan devices”.
N.B. remember that you must keep the bluetooth active throughout the operation.

6.

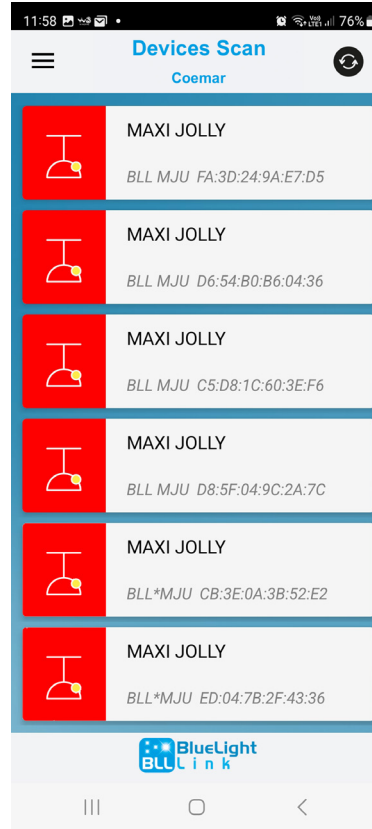

All detected projectors will pop up on screen.

7.

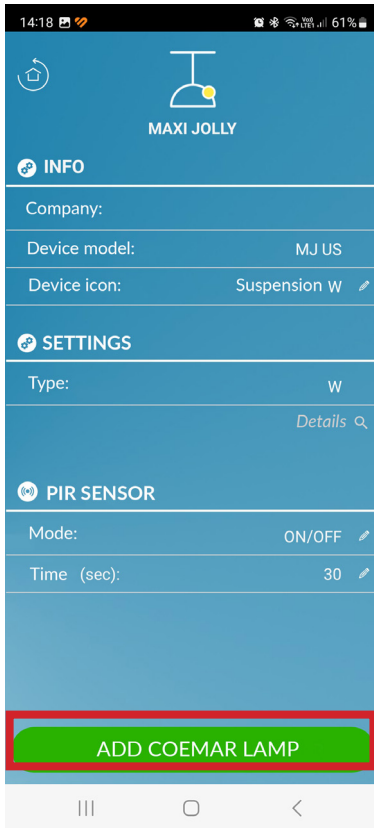

Once you have selected a projector you will see this screen. At this point the projector will start to flash), then click on **ADD COEMAR LAMP** (here will appear the name of your **network** instead of **COEMAR**).

8.

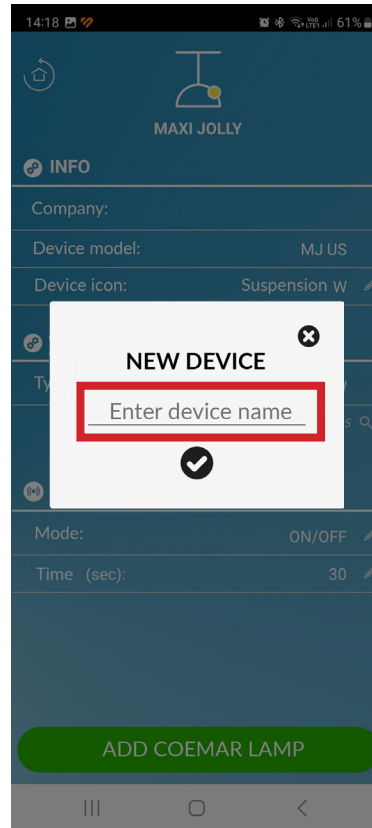

Name the projector at your convenience and confirm.

9.

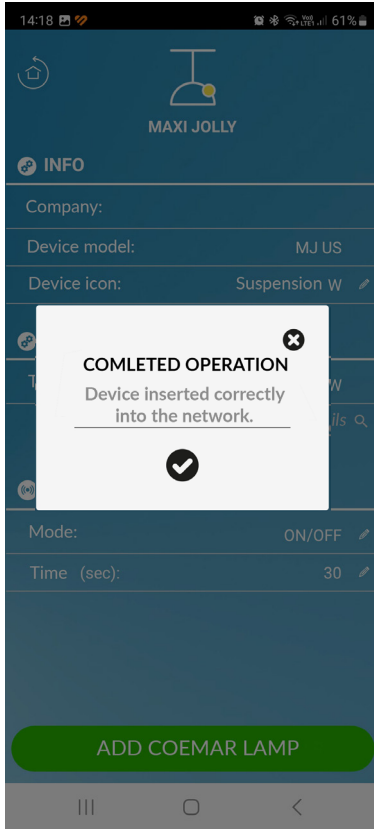

A confirmation and completion message will appear.

10.

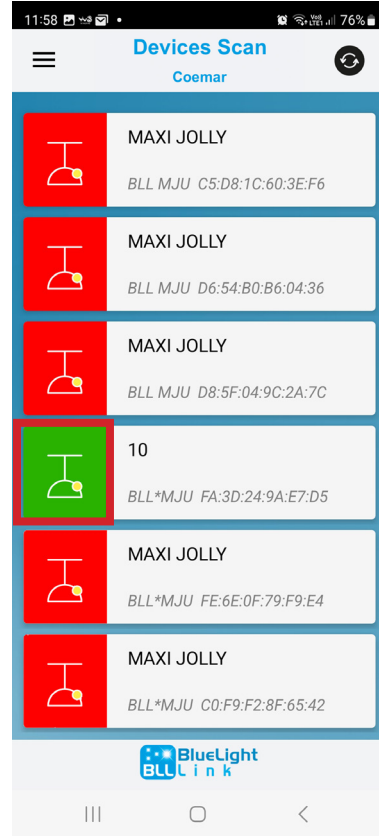

Once completed, the app automatically returns to the "Scan devices" section. On the screen you can see the devices you have connected, marked with the green icon).

11.

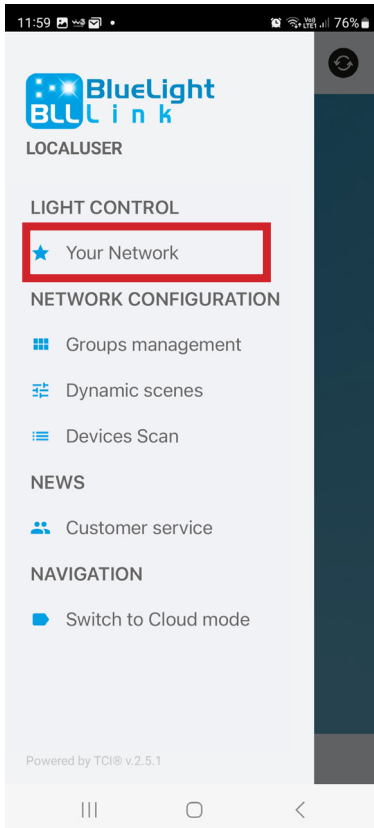

To manage the operation of the products click on the menu consisting of three dashes in the upper left and select "Your Network".

12.

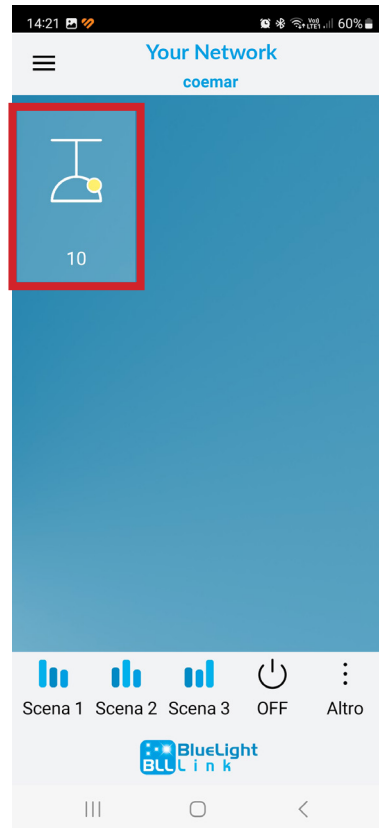

Here you will see the list of products connected so far.

13.

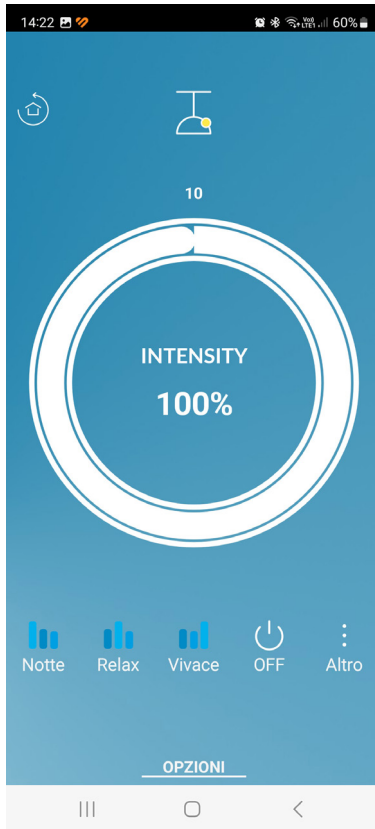

Once you have selected the product a screen will open that will allow you to control it as you want.

14.

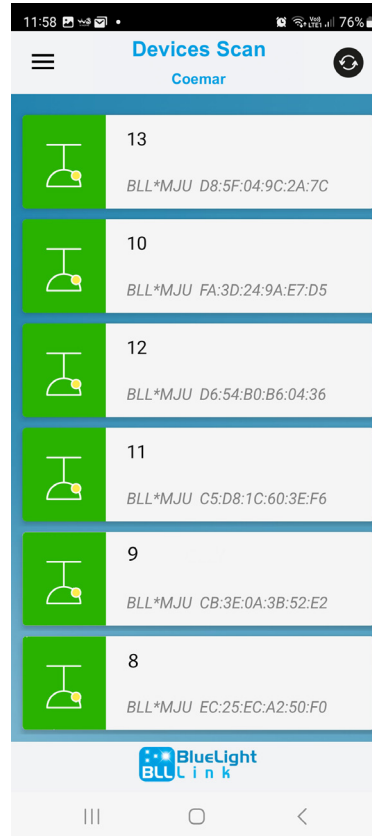

This is the screen you will see when all your products are associated.

IMPORTANT INFORMATION: You must disconnect the products before you can use them on another mobile device. Otherwise they will not be detected.

15.

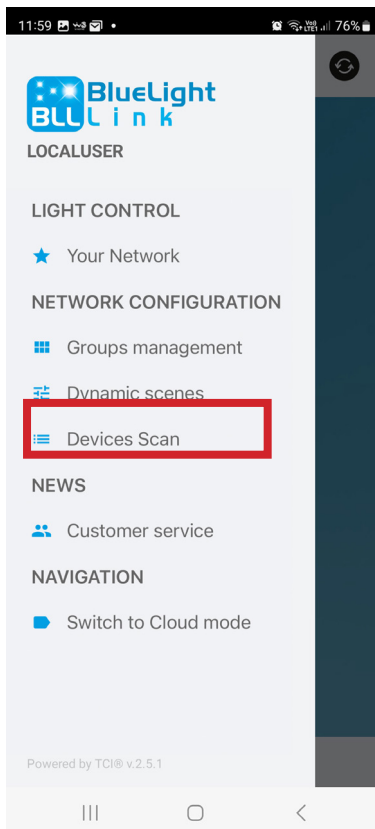

To disconnect the devices select again on the menu consisting of three dashes in the upper left and select “**Scan devices**”.

16.

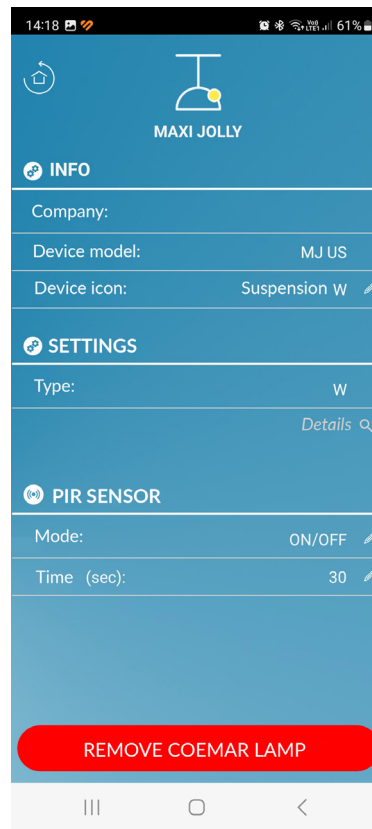

Select the projector you want to dissociate (this will start to flash) and then click on **REMOVE COEMAR LAMP** (here will appear the name of your **network** instead of **COEMAR**).

17.

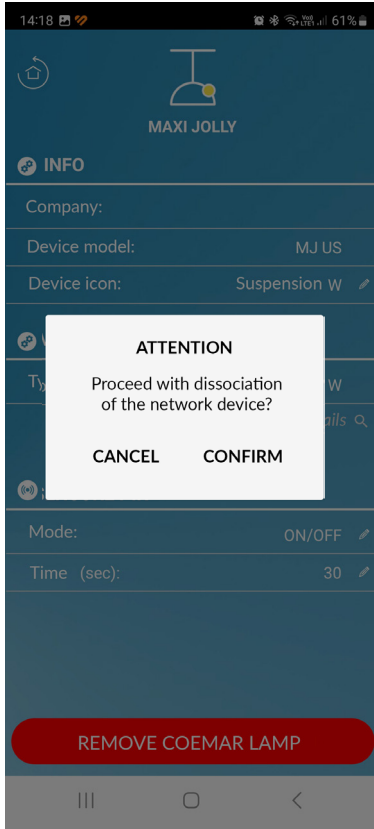

A message will appear where you need to confirm.

18.

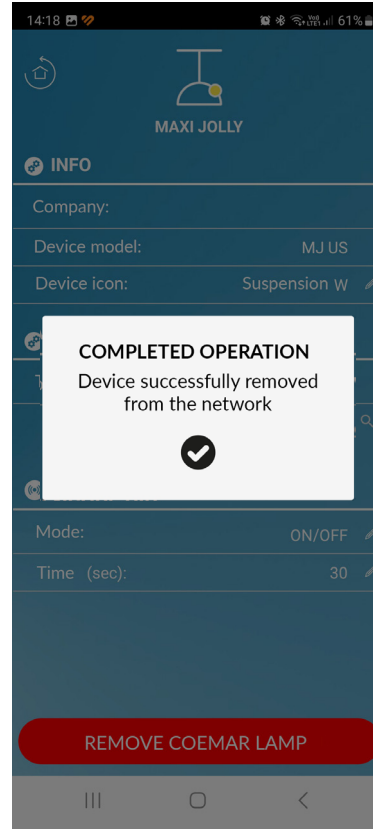

A confirmation and completion message will appear.

19.

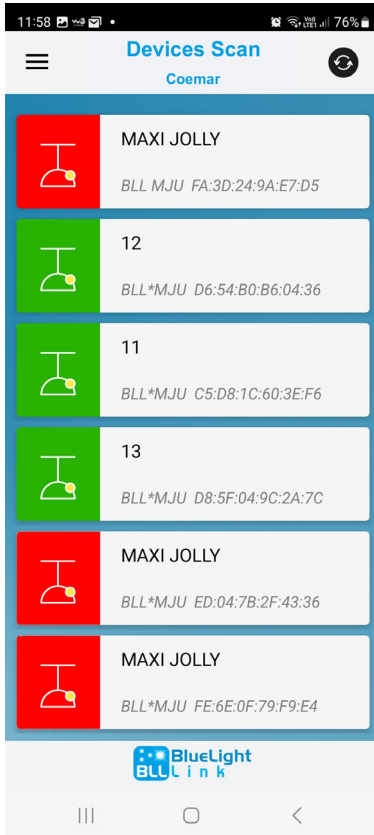

Once completed, the app automatically returns to the "Scan devices" section. On the screen you can see the devices you have disconnected, marked with the red icon).

13. Accessories and spare parts

MiniLEDko is a very versatile fixture, optional accessories for its customization are available under request:

13.1 MiniLEDko Profile

Accessory name	Code
Profile Zoom 15° - 35°	BC013A020
Lens Tube Profile 19°	BC013A000
Lens Tube Profile 26°	BC013A001
Lens Tube Profile 36°	BC013A002
Lens Tube Profile 50°	BC013A003
Metal gobo holder (included)	BC013A008
Glass gobo holder (optional)	BC013A009
Front barrel (optional)	BC013A100
Color frame holder (included)	BC013A006
Track adaptor for ceiling or clamp fixing (for track version T/D - clamp not included), compatible only with the version with on board potentiometer control	BC015A300

13.2 MiniLEDko Fresnel

Accessory name	Code
4 leaf barndoor (included)	BC013A014
Honeycomb - 4 mm / 0.16 in	BC013A015
Honeycomb - 6 mm / 0.23 in	BC013A016
Support for accessories	BC013A019
Track adaptor for ceiling or clamp fixing (for track version T/D - clamp not included), compatible only with the version with on board potentiometer control	BC015A300

13.3 MiniLEDko Spot

Accessory name	Code
Lens 16°	BC016A000
Lens 22°	BC016A001
Lens 27°	BC016A002
Front Barrel for Lens 16° and 22°	BC016A100
Front Barrel for Lens 27°	BC016A110
Metal key for gobo mounting (included)	BC016A010
Track adaptor for ceiling or clamp fixing (for track version T/D - clamp not included), compatible only with the version with on board potentiometer control	BC015A300

All the components of **MiniLEDko Series** are available as spare parts from your Coemar dealer or Service. Accurate description of the fixture, model number and type will assist us in providing for your requirements in an efficient and effective manner.

14. Maintenance

14.1 Firmware update

The firmware of **MiniLEDko** can be updated through the RDM protocol (ANSI E1.20). Contact Coemar assistance to receive the software and the device updater (AC10011A000).

14.2 Periodic cleaning

Lenses

Even a thin layer of dust can reduce the luminous output and alter the consistency of the beam. Regularly clean all filters and lenses using a soft cotton cloth, dampened with a special lens cleaning solution.

Cleaning of the unit

Use a soft brush or a common vacuum cleaner or a source of compressed air for removing dust. For the cleaning of the housing use a soft cloth and a non-aggressive cleaner. Check that the internal fans and heat exchanger must be perfectly clean.

14.3 Periodic controls

Mechanical components

Check the correct working of the mechanical parts and, if needed, replace them. Make sure the projector is not mechanically damaged. If necessary, replace the worn parts.

Electrical components

Check all electrical connections, in particular for correct grounding and correct attachment of all extractable connectors. Press the connectors if necessary and reposition as before.

15. F.A.Q. and answers

The following list shows common issues that may be simply solved. If issues persist, the unit must be repaired by a qualified personnel or just contact your **Coemar** service near you.

Question	Possible solution
MiniLEDko Profile does not emit light	Projector not powered on: <ul style="list-style-type: none">• Make sure the power cord is plugged in or test the input voltage. Wrong DMX address: <ul style="list-style-type: none">• Check the DMX Address setting and the output signal of the controller.
MiniLEDko Profile is not responding to DMX signal	DMX signal may not reach MiniLEDko Profile: <ul style="list-style-type: none">• Inspect the cable connection, correct poor connections or inefficient repair or replace damaged cables.• Check DMX address of the unit.

Help from Coemar Technical Services

If you are having difficulties and your problem is not addressed by this document, contact Coemar Technical Services directly at one of this email address:

info@coemar.com / service@coemar.com

Or call the number **+39 0376 1514412**

When calling for help, take these steps first:

- Prepare a detailed description of the problem
- Go near the equipment for troubleshooting



Information on disposal of the equipment

The equipment at the end of its useful life must be disposed of at an appropriate recycling center for waste electrical and electronic equipment. The treatment and disposal of environmentally friendly, helps prevent potential negative environmental and health and promote the reuse and / or recycling of materials making up the equipment. Illegal disposal by the user includes the application of administrative sanctions provided by law.



Coemar Lighting s.r.l.

Via Carpenedolo 90

46043 Castiglione delle Stiviere, Mantova, Italy

phone. +39 0376/1514412 - fax +39 0376/1514380

info@coemar.com

Coemar reserves the right to change specifications without prior notice