

Otello 8 HD FullSpectrum +

Last update:
23/04/2024

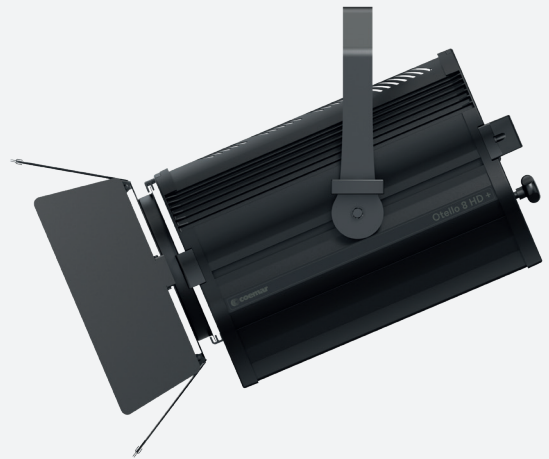

Otello 8 HD + with 8 leaf barn door

Introducing

● Developed to offer the best solution in the stage lighting field focussing on **theatre and TV studios applications**, Otello Led Fresnel incorporates all traditional characteristics of a Fresnel light such as the **distinctive soft-edged** and **very wide beam** and the **smooth and homogeneous light field**.

The improved **HD electronic** with an advanced LED controller guarantees a smooth 20 bit dimming and a superlative **color mixing**.

Next to the traditional manual or P.O. option, Otello offers an optional motorized zoom, which together with a modern design and Oled display with on-board selector for quick setting represents the state of the art in terms of LED Fresnel range. The family consists of 2 fixtures with lenses of 150 mm (5,9 inch) and 200 mm (7,87 inch). All variants include COB, VariWhite, Studio and FullSpectrum 6 LEDs in 3 power steps.

● **FullSpectrum** : 2.700 – 20.000 K (CRI average > 95); Red, Green, Blue, Cyan, Lime, Amber color mixing with Green-Magenta adjustment

● **VariWhite | Tungsten | Daylight**: white engines with the Tungsten and Daylight COB LED calibrated respectively at 3.000 K and 5.600 K CCT and a tunable white source ranging from 2.800 to 6.500 K (CRI > 94) for the VariWhite version

Key Features



- Red, Green, Blue, Cyan, Lime, Amber light source, 20 bit color mixing
- Green-Magenta adjustment
- Color mixing with hue and saturation control



- High CRI > 95



- CCT 2.700 K → 20.000 K



- Fresnel lens (diameter: 200 mm / 7.87 in)
- Zoom range from 7° to 68° half peak angle
- Available with Manual or Motorized Zoom



- Extruded aluminum, flame-retardant technopolymer reinforced with fiberglass



- Custom color on request (optional)



- Manual (standard) or Pole Operated Pan-Tilt (Optional)

General	
● LED Source	RGBCLA COB LED (Red, Green, Blue, Cyan, Lime, Amber) - Color mixing with hue and saturation control
● CCT Range	●●●●● CCT from 2.700 K to 10.000 K (through DMX) or up to 20.000 K (through Display)
● Color Rendition Average	CRI> 95, TLCI> 95
● Dimming	8 or 16 bit, 5 selectable curves: Exponential, Logarithmic, Linear, Halo and Standard
● Dimming Smooth Selection	Fast, Slow and Very Slow
● Strobe	Electronic strobe, synchronized, random, pulse effect
● Lens	Glass fresnel lens (diameter: 200 mm / 7.87 in)
● Optical	Zoom range from 7° to 68° (motorized, manual or PO zoom available)
● Green-Magenta adjustment	Continuously adjustable (Full Minusgreen to Full Plusgreen)
● Color saturation function	Generated colors fades to White tone selected with the CCT channel
● Dim to Warm function	Halogen lamp dimmer simulation
● Camera flicker control/Hz range	Yes: 20.000Hz
● Calibrated Cob	Yes
● L80 Rating (hours to 80% output)	50.000 Hours

Electrical	
● Voltage Input	80-264 V, 50/60 Hz, auto-sensing
● Power Consumption	330 W Maximum - 1.53 A at 230V, 2.93 A at 115V - cosφ: 0.94 (manual / P.O. zoom) 340 W Maximum - 1.57 A at 230V, 3.02 A at 115V - cosφ: 0.94 (motorized zoom)
● Power Connection	In and Out PowerCON TRUE1 Top connectors to feed up to 8 (at 230V) or 4 (at 115 V) fixtures
● Data Connection	In and Out DMX 5 pin locking XLR connectors

Thermal	
● Ambient Operating Temperature	0°C - +40°C (32°F - 104°F)
● Fan (controllable)	Yes, 4 different settings: Silent, Studio, Auto, DMX Regulated

Control	
● Protocols	DMX-512, RDM (Remote Device Management), Wireless (optional By LumenRadio)
● RDM configuration	Yes
● DMX Channels	Manual / PO zoom version: 16 / 7 / 1 / Studio mode / RGB mode / fine RGB mode / Sunrise mode Motorized zoom version: 17 / 8 / Studio mode / RGB mode / Fine RGB mode / Sunrise Mode
● Display	Graphic OLED with on-board selector for quick setting
● Firmware upgrade	Through DMX with RDM Upgrade USB interface (code AC10011A001)

Physical	
● Yoke	Manual (standard) or Pole Operated Pan-Tilt (Optional)
● Materials	Extruded aluminum, flame-retardant technopolymer reinforced with fiberglass
● Weight	13.5 Kg / 29.76 lbs
● Length	489 mm / 19.25 in
● Height	315 mm / 12.40 in
● Height with Yoke	With Manual Yoke: 437 mm / 17.20 in - With Pole Operated Yoke: 621 mm / 24.45 in
● Width	With Manual Yoke: 313 mm / 12.32 in - With Pole Operated Yoke: 406 mm / 15.98 in
● IP Rating	IP20
● Color options	Black (standard), custom color on request (optional)

Included accessories	
BC10044A002	8-Leaf Barndoor
GKIT17 (USA) / GKIT16 (EU)	1.5 m power cable with PowerCON TRUE1 Top and bare ends
BC10044A006	Color frame holder



Otello 8 HD + (manual zoom)
Rear Panel with the new OLED
display



Otello 8 HD + with
Pole Operated Yoke and Pole Operated
Zoom

Otello 8 HD+ PO version / Rear Panel

DMX Charts - Manual Zoom

16 Channels	7 Channels	1 Channel	Fine RGB Mode
01 → Master Dimmer	01 → Master Dimmer	01 → Master Dimmer - Color	01 → Master Dimmer
02 → Red	02 → Red	Temperature Settable by Display	02 → Dimmer Fine
03 → Green	03 → Green		03 → Red
04 → Blue	04 → Blue		04 → Red Fine
05 → Cyan	05 → Cyan		05 → Green
06 → Lime	06 → Lime	RGB Mode	06 → Green Fine
07 → Amber	07 → Amber	01 → Master Dimmer	07 → Blue
08 → Strobe Effect		02 → Dimmer Fine	08 → Blue Fine
09 → Dimmer Fine		03 → Red	09 → White Tone
10 → Special Functions	Studio Mode	04 → Green	10 → Saturation
11 → Red Tone	01 → Master Dimmer	05 → Blue	11 → Strobe
12 → Green Tone	02 → White Tone	06 → White Tone	12 → Special Functions
13 → Blue Tone	03 → Green Saturation	07 → Saturation	
14 → White Tone	04 → Saturation	08 → Strobe Effect	Sunrise Mode
15 → Green Saturation	05 → Hue	09 → Special Functions	01 → Master Dimmer
16 → Saturation	06 → Dimmer Fine		02 → Dimmer Fine
	07 → Special Functions		03 → Proportional CCT
			04 → Step CCT
			05 → Green Saturation
			06 → Special Functions

17 Channels

01 → Master Dimmer
 02 → Red
 03 → Green
 04 → Blue
 05 → Cyan
 06 → Lime
 07 → Amber
 08 → Strobe Effect
 09 → Dimmer Fine
 10 → Special Functions
 11 → Red Tone
 12 → Green Tone
 13 → Blue Tone
 14 → White Tone
 15 → Green Saturation
 16 → Saturation
 17 → Zoom

8 Channels

01 → Master Dimmer
 02 → Red
 03 → Green
 04 → Blue
 05 → Cyan
 06 → Lime
 07 → Amber
 08 → Zoom

Studio Mode

01 → Master Dimmer
 02 → White Tone
 03 → Green Saturation
 04 → Saturation
 05 → Hue
 06 → Dimmer Fine
 07 → Special Functions
 08 → Zoom

RGB Mode

01 → Master Dimmer
 02 → Dimmer Fine
 03 → Red
 04 → Green
 05 → Blue
 06 → White Tone
 07 → Saturation
 08 → Strobe Effect
 09 → Special Functions
 10 → Zoom

Fine RGB Mode

01 → Master Dimmer
 02 → Dimmer Fine
 03 → Red
 04 → Red Fine
 05 → Green
 06 → Green Fine
 07 → Blue
 08 → Blue Fine
 09 → White Tone
 10 → Saturation
 11 → Strobe
 12 → Special Functions
 13 → Zoom

Sunrise Mode

01 → Master Dimmer
 02 → Dimmer Fine
 03 → Proportional CCT
 04 → Step CCT
 05 → Green Saturation
 06 → Special Functions
 07 → Zoom

Drawing Size - Manual Yoke Version

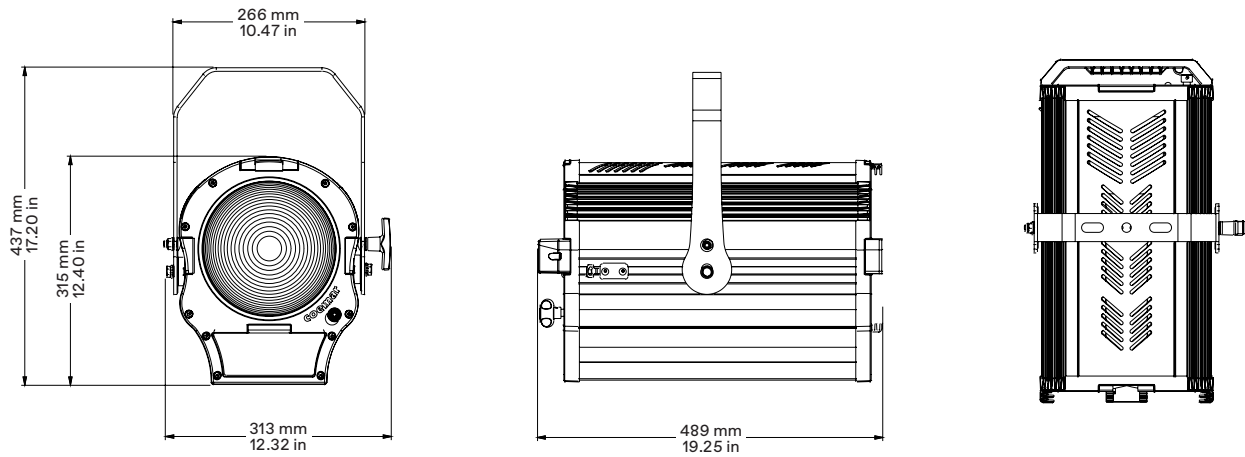

Drawing Size - Pole operated Yoke Version

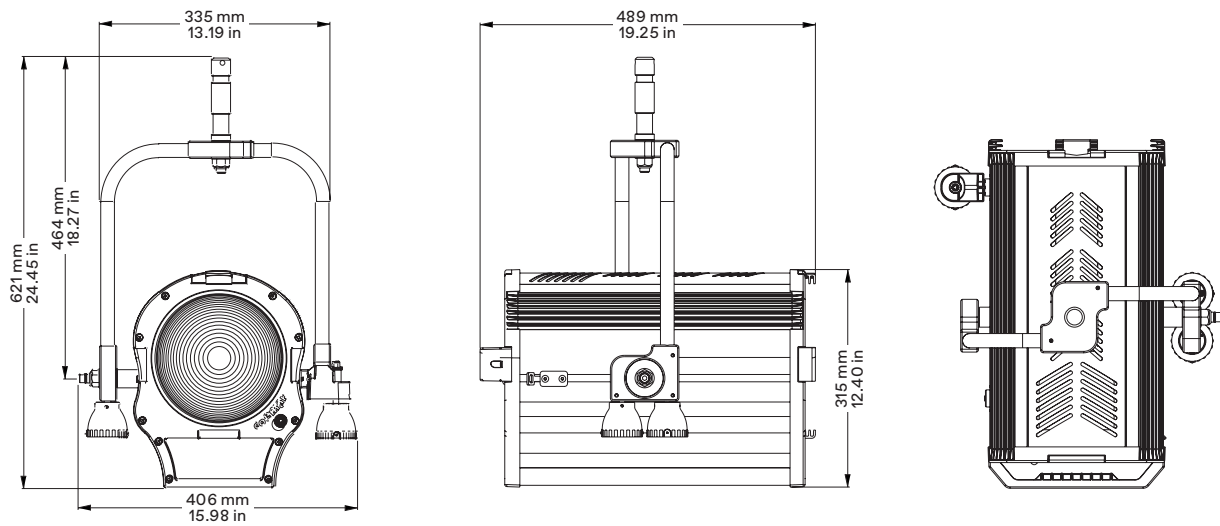

Models

Product	Code
Otello 8 FullSpectrum + Manual Yoke, Manual Zoom	F144Q090Q
Otello 8 FullSpectrum + Manual Yoke, Motorized Zoom	F144Q000Q
Otello 8 FullSpectrum + Pole Operated	F144Q010Q



Theatre - Teatro Lirico di Cagliari, Italy

Products
Version

Otello 8 HD FS
Motorized Zoom

● Coemar Lighting S.r.l.

Via Carpenedolo, 90
46043, Castiglione delle Stiviere (MN) – Italy

P. +39 0376 1514412

M1. info@coemar.com

M2. service@coemar.com

W. coemar.com

P.iva – C.f. 02415330204

